



Hearth Products Controls Co
www.HPCfire.com

FPPK Flame Control System



Installation

We suggest that our products be installed by professionals that are locally licensed by the authority having jurisdiction in gas piping.

Service



We suggest that our products be serviced by a professional certified in the US by the National Fireplace Institute (NFI) as NFI Gas Specialists.

⚠ WARNING: FOR OUTDOOR USE ONLY

⚠ WARNING

•Improper installation, adjustment, alteration, service, or maintenance can cause injury or property damage. Read the installation, operating, and maintenance instructions thoroughly before installing or servicing this equipment.

⚠ WARNING

•Do not store or use gasoline or other flammable vapors and liquids in vicinity of this or any other appliance.
•An LP-cylinder not connected for use shall not be stored in the vicinity of this or any other appliance.

⚠ DANGER

If you smell gas:

- 1) Shut off gas to appliance.
- 2) Extinguish any open flame.
- 3) If odor continues, keep away from appliance and immediately call gas supplier or fire department.

INSTALLER: Leave this manual with the appliance.
CONSUMER: Retain this manual for future reference.

Index:

General Information

- 1) General Information
- 2) Selecting the Location
- 3) Construction of Enclosure
- 4) Installation of Fire Pit
- 5) Media

Product Specific Information

- 6) Parts List
- 7) Installation of Flame Control System
- 8) Fire Pit Operation
- 9) Maintenance
- 10) Troubleshooting
- 11) Warranty

1) General Information

Instructions are also available at HPCfire.com

Please carefully follow the instructions in this manual to prevent personal injury or property loss. Instructions are updated as needed. It is the installer's responsibility to periodically review instruction for applicable updates.

The steps listed as:

WARNINGS: Contains information critical to the safe installation and operation of the fire-pit.

WARRANTY REQUIREMENT: Must be strictly followed to qualify for product warranty.

Warranty will be void if not followed.

IMPORTANT: Are notes and insights to help ensure product satisfaction and serviceability.

WARNING: It is the installer's responsibility to ensure a safe installation and to educate the end user as to proper operation. Leave this manual with the end user.

WARNING: We suggest that our products be installed by professionals that are locally licensed by the authority having jurisdiction in gas piping. We suggest that our products be serviced by a professional certified in the US by the National Fireplace Institute (NFI) as NFI Gas Specialists or in Canada by WETT (Wood Energy Technical Training). Installer must follow all instructions carefully to ensure proper performance and safety. Hearth Products Controls Company is not responsible for your actions.

WARNING: Product is not intended to be a starter for wood or any other combustibles.

WARNING: It is the responsibility of the installer to follow ALL LOCAL CODES concerning the installation and operation of the fire pit. In the absence of local codes, please follow:

- Fixed piping system: The *National Fuel Gas Code, ANSI Z223.1/NFPA 54* or *International Fuel Gas Code*.
- Electrical ground: The *National Electrical Code, ANSI/NFPA 70*.

WARNING: Only use gas/fuel type specified for this fire pit see label on the fire pit control Box. Verify correct gas/fuel type and pressure. Never use an alternative fuel to include bio-fuel, ethanol or any other fuel.

Gas pressure and type should be checked prior to use and installation.

- Natural Gas Fire Pit:

Supply Pressure: Minimum: 3.5" W.C.; Maximum: 7.0" W.C.

- LP Gas:

Supply Pressure: Minimum: 8.0" W.C.; Maximum: 11.0" W.C.

2) Selecting the Location

WARNING: All fire pits, match lit kits, spark ignition, safety pilot and electronic ignition systems are designed and intended for outdoor use only.

WARNING: All fire pits must have a gas shutoff on the outside of the exterior of the fire pit to allow for emergency shut off and maintenance. The gas shutoff should not be used to adjust flame height.

WARNING: Select a location where the fire pit can be attended during operation. Never leave an operating fire pit unattended or by someone not familiar with its operation or emergency shut off locations.

WARNING: Both children and adults should be alerted to the hazards of high surface temperatures and should stay away to avoid burns and clothing ignition.

WARNING: Young children should be carefully supervised when they are in the area of fire pit.

WARNING: Clothing or other flammable materials should not be placed on or near fire pit.

WARNING: Fire pits create very high temperatures - Combustibles must be located far enough away that there is no risk of ignition.

WARNING: Overhead Clearance applies to tree limbs and branches only- DO NOT install unit under overhang or ceiling.

IMPORTANT: It is recommended that material such as granite, marble or other dense stone be kept away from heat and especially flame due to risk of cracking. Manufacturer is not responsible for damage

Fire Pit Clearances – See Figure 1 On Last Page	Up to 200k btu
Under Valve Box When Applicable For Drainage	2"
Sides Surrounding Fire Pit From Structure or Combustibles	36"
Overhead Clearance Above Product	84"

- Select a location with good drainage.
- Choose a location that allows easy access for installation and maintenance of the fire pit.
- Pick a location that allows sufficient horizontal room to enjoy the fire pit while allowing a safe distance from the heat and flame.

3) Construction of the Enclosure

WARNING: All fire pits must have a gas shutoff on the outside of the exterior of the fire pit to allow for emergency shut off and maintenance. The gas shutoff should not be used to adjust flame height.

WARNING: Use non-combustible materials and construction for gas supply, power and enclosure. A metal outlet box should be used inside the enclosure for electronic ignition models.

WARNING: Always use proper materials and construction for gas supply, power and enclosure.

WARNING: We prefer the enclosure incorporate 4 vents total (minimum 18 sq. inches each side) to reduce the risk of thermal shutdown on the EI Series- some enclosures may require more ventilation based on material, size and extended use. The minimum requirement is the enclosure incorporate 1 vent on at least 2 sides (2 vents total) at a minimum size of 18 sq. inches of total free area each (Example: 3”x 6” or larger) to ensure that heat and residual gas can escape. Installation of the vents in the mid to lower area of the enclosure is recommended. Failure to properly vent enclosure may result in the fire pit overheating or explosion. Continuous overheating could lead to heat damage to internal components. The vent may work as a drain as well when installed at bottom sidewall to prevent water build up.

WARNING: The interior void space of the enclosure surrounding the valve box cannot be filled with any material (gravel, crushed rock, concrete, etc.)- It is a requirement to have a minimum of 2” under the valve box for proper ventilation and drainage.

WARNING: Select materials that are non-combustible in both initial installations as well as over time.

WARNING: The fire pit assembly should be recessed a minimum of 2.25” from the top of the enclosure to protect flame from being blown out. Some areas may require more- 4 to 6” is not uncommon.

WARRANTY REQUIREMENT: The enclosure must be constructed on a stable surface. The weight of the fire pit must be supported by the pan and not by any control/valve box. For electronic ignition models the control/valve box must be above grade with adequate drainage to prevent water damage to the controls inside the box.

- Make sure that the structure is level. We recommend the use of the installation collar (optional) that may be mortared into the surround.
- HPC recommends that the pan lip is recessed on trough (linear), and large round products as illustrated below. HPC cannot guarantee the lip on all of our products will be perfectly flat and will not warp due to heat.

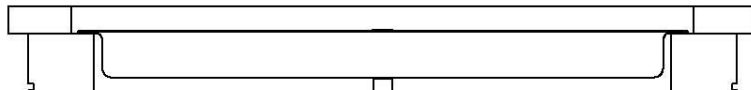

IMPORTANT: Product must be accessible for service.

WARRANTY REQUIREMENT: Do not daisy chain wiring for multiple fire pit installations. Each fire pit must have dedicated wiring.

4) Installation of a Fire Pit

Installation

We suggest that our products be installed by professionals that are locally licensed by the authority having jurisdiction in gas piping.

WARNING: We suggest that our products be installed by professionals that are locally licensed by the authority having jurisdiction in gas piping.

WARNING: We suggest that our products be serviced annually by a professional certified in the US by the National Fireplace Institute (NFI) as NFI Gas Specialists.

WARNING: Confirm this appliance is built for gas used –natural gas or LP. Do not use natural gas appliance with LP or LP appliance with natural gas. Refer to the label on the appliance.

WARNING: To prevent damage, unhook fire pit from gas supply for pressure leak tests.

WARNING: Ensure that the mounting plate for the valve is properly secured to a rigid surface on the enclosure, check that the mounting plate will not move.

WARNING: Operate valve to ensure there is no movement and the valve is secure.

WARNING: Orient the valve so that there is no kink in the flex line.

WARNING: During the installation of the fire pit insert, check to ensure the flex line will not kink or pinch to avoid damage to the flex line.

WARNING: After hooking up the gas supply line, ensure the valve mounting is still secure.

WARNING: Check all connections and lines to ensure they are not under stress.

WARNING: Perform leak test on all connections. Repair as needed and double check that all mounting hardware is secure with no movement.

WARNING: Fuel line sizing is the responsibility of the installer and must be able to supply the stated maximum BTU for the product.

WARNING: Burn testing- It is the responsibility of the qualified installer to test for gas leaks at all connections.

WARNING: When filling the pan with lava rock and/or decorative glass, the instructions in Section 5 must be followed.

WARNING: If using a small LP tank as a fuel source refer to the FPLP kit and instructions.

WARNING: Gas Plumbing Connections: Use only joint compound or tape that is resistant to all gases. Apply joint compound to all male pipe fittings only- DO NOT use on FLARED fittings. Be sure to tighten every joint securely.

WARNING: For systems with an extended or detached valve box the area in which the valve box is installed must conform to all installation requirements to include but not limited to location, construction, venting and local codes. Failure to do so may result in personal injury property damage or explosion.

IMPORTANT: Ensure any flex line that may be used from the permanent main fuel supply to the product is rated to the stated max BTU of the product and certified to ANSI Z21.75*CSA 6.27.

WARRANTY REQUIREMENT: Warranty is void if product is altered.

- Refer to cut sheets on our website for important dimensional information for your fire pit.
- Plan your project well in advance to comply with all instruction and codes and allow for access and serviceability of the product.
- Purge gas lines of air.
- Perform all leak tests with leak detector or leak reactant.
- Verify correct gas type and pressure.
- Perform leak test on main gas supply and repair as needed.
- Shut off gas supply to fire pit.
- Connect fire pit to main gas supply. If using flex line avoid sharp bends with flex line to prevent whistling.
- Turn on gas supply and perform leak test on all inlet connections and repair as needed.
- Position fire pit safely with access to all gas connections for testing.
- Light fire pit. It may take several cycles to purge air from the lines.
- Once fire pit is lit perform leak test on all gas connections. Repair as needed.
- Turn off fire pit and allow cooling.
- Apply media as described in (Section 5.)
- Turn on fire pit again and perform leak test with media correctly installed. If gas leak is detected verify correct media application and repair as needed.
- Set fire pit in properly constructed enclosure (Section 3.)
- Verify correct operation and lighting.
- Review safety manual with end user and instruct not to change/ modify fire pit or media.
- Leave manual with end user.

5) Media

▲ WARNING: FOR GLASS MEDIA USAGE WITH LP GAS- WHEN USING APPROVED DECORATIVE GLASS TO COVER BURNER APPLY ONLY ENOUGH TO HIDE BURNER. APPLYING OVER 1/2" MAY CREATE BACK PRESSURE AND GAS LEAKAGE FROM AIR MIXER RESULTING IN LP POOLING UNDER FIRE PIT.

▲ WARNING: FOR GLASS MEDIA USAGE WITH LP GAS- THE UNIT MUST BE TESTED WITH MEDIA OVER BURNER FOR CONFIRMATION OF NO BACK PRESSURE CREATING GAS TO LEAK OUT OF AIR MIXER VENTURI HOLES. THIS MAY HAVE TO BE DONE PRIOR TO PLACING IN ENCLOSURE IF NO ACCESS DOOR.

WARNING: The fire pit is designed to use approved media correctly installed over the burner to achieve proper combustion.

WARRANTY REQUIREMENT: Never install a mesh or screen under the media.

IMPORTANT: Media affects flame pattern greatly. It is possible to create an unusual flame pattern that could damage your enclosure. Enclosure damage from an open flame fire feature is not covered under any warranty.

IMPORTANT: Lava rock/glass coverage should be at a minimum to prevent smothering of the flame and for correct operation – See “Lave Rock & Glass Application” instructions before applying.

IMPORTANT: The use of concrete logs is not recommended.

Lava Rock & Glass Application

Please follow the instructions below to add the finishing touch to your fire pit. Particular attention needs to be on the pilot assembly area. Incorrect media installation will cause the pilot flame to suffocate and turn off pit or delay main burner ignition.

Lava Rock Application- Standard size, 1"~3" pcs. (part #657)

- 1) Install your fire pit per instructions.



- 2) Apply standard lava rock only deep enough to cover ring and pan- less than 2" above fire ring.



Lava Rock Application- Large size, 4"+ pcs.

- 3) Apply base coat of standard size lava rock as in Step 2, then place large size lava rock loosely on top.

For Electronic Ignition

- 4) Blowout Box: Do not cover blowout box vents or opening with lava rock or glass. Incorrect media installation will cause the pilot flame to suffocate and turn off pit or delay main burner ignition.



Decorative Glass Application

- 1) Install your fire pit per instructions.



- 2) Fill Pan with glass. Cover burner with 1/8 to 1/4" of glass. Do not over fill with glass. All LP installations must be checked for back pressure with media installed. Failure to do so may result in personal injury or property damage.



For Electronic Ignition

- 3) Blowout Box: Do not cover blowout box vents or opening with lava rock or glass. Incorrect media installation will cause the pilot flame to suffocate and turn off pit or delay main burner ignition.



DO NOT COVER VENTS!



DO NOT COVER PILOT OPENING!

6) Parts Lists

1. FPPK Flame Control System
2. Instructions

7) Installation FPPK Flame Control System

WARNING: Perform leak test on all fittings and back pressure checks for LP with media installed.

Installation

We suggest that our products be installed by professionals that are locally licensed by the authority having jurisdiction in gas piping.

LP Installations:

WARNING: For LP air-mixers confirm “Gas In” is towards control valve or shutoff valve. Installing backwards will result in severe gas leak and risk of explosion. If your air-mixer has an adjustment nut adjust to desired flame condition.

WARNING: A pan must be used on LP systems and configured in way to minimize fuel settling below the pan. Failure to do so may result in personal injury or explosion.

WARNING: For LP Installations the air-mixer should be positioned near the burner with one coupler between the burner and the air-mixer. Do not attach Air Mixer directly to burner. This may increase back pressure.

WARNING: If the Flame Control System will be extended away from the burner the air-mixer should be positioned on the burner side of the extended pipe or flex line.

WARNING: Always do thorough leak and back pressure checks on all fittings and air-mixers with media in place. This may need to be done with the fire pit outside of the enclosure.

WARNING: Never alter the unit.

WARNING: Do not put an elbow immediately after an air-mixer. This may increase the chance of back pressure.

WARNING: Never add anything after an air-mixer that would act to impeded gas flow. This may increase the risk of back pressure.

WARNING: Ensure the burner selected has sufficient flow capacity as to not create back pressure.

WARNING: Ensure correct air mixer size as described below.

- 40K (Standard 127LC - for use with HPC 6” Round, 36” T and smaller)
- 90K (Standard 127 - for use with HPC 12” PENTA, 12” Round, 12” square, 48” T and larger)
- 150K (Properly Sized 127 - for use with HPC 18” PENTA, 18” Round, 72” T and larger)

Sizing recommendations is based on HPC burners only. Installer is responsible for correct sizing based on the application and must follow all instructions and local codes to include but not limited to back pressure checks with media.

WARNING: Perform leak test on all fittings and back pressure checks for LP with media installed.

Sizing recommendations is based on HPC burners only. Installer is responsible for correct sizing based on the application and must follow all instructions and local codes to include but not limited to back pressure checks with media.

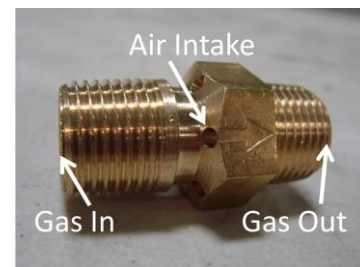

Pilot Assembly Mounting:

WARNING: The Pilot assembly must be directly beside burner with center of pilot flame window lined up above a burner hole to ensure main burner ignition. Misalignment will cause delayed ignition of main burner.

WARNING: A pan must be used on LP systems and configured in way to minimize fuel settling below the pan. Failure to do so may result in personal injury or explosion.

WARNING: For systems with an extended valve box the area in which the valve box is installed must conform with all installation requirements and local codes. Failure to do so may result in personal injury property damage or explosion.

WARRANTY REQUIREMENT: Do not route the igniter wire near metal material as this may cause voltage to leak to ground and reduce igniter power.

WARRANTY REQUIREMENT: If no pan is used (on natural gas systems only) accommodations must be made to protect igniter wires and thermocouple tube from flame.

IMPORTANT: For proper operation, it is required for the pilot assembly to receive fresh air from underneath.

IMPORTANT: Do not block pilot assembly blow out box underside with media (lava rock or glass)- must remain open.



Pilot Window with flame.

Pilot Assembly

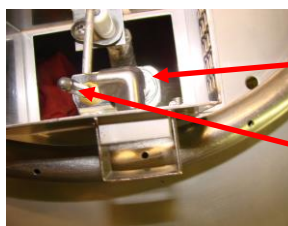

Pilot Hood

Thermocouple- flame sensing

Pilot Assembly Components

Pan Mounting:

WARNING: Pilot assembly should be directly beside burner with center of pilot flame window lined up above a burner hole to ensure main burner ignition. Miss alignment will cause delayed ignition of main burner.

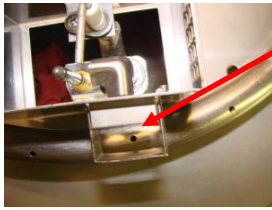

Pilot Window
lined up with burner hole.

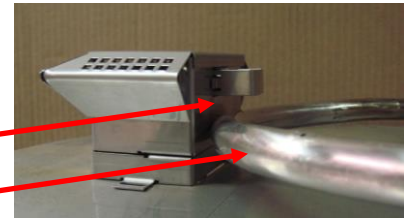

Pilot Window: Above burner.

Burner

- 1) Cut rectangular hole (2.8" x 1.75") in pan for pilot assembly mounting (see drawing below).
- 2) Drill two (2) 5/32" bolt holes for mounting of pilot assembly.

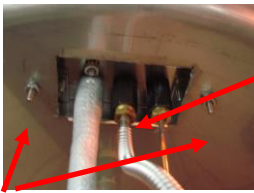

Bolt Holes (2) **Bottom View**

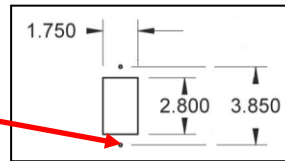

Rectangular Hole

Pilot Assembly Footprint



Top View- note next to burner

IMPORTANT: Do NOT reduce rectangular hole size- must be large to prevent suffocation of pilot flame.

Burner Mounting:

The pilot assembly can also be mounted directly to the burner using our 120-HWI bracket (optional). The center portion of the T-pilot hood should be aligned with a burner hole as shown above. Care must be taken to prevent flame from being blown under the pilot assembly and damaging wire or connections.

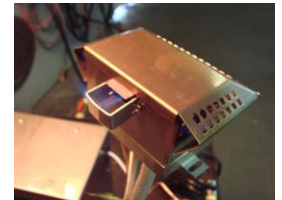

Water in Valve Prevention: HPC does not cover water in the valve under warranty.

WARRANTY REQUIREMENT: Fire Ring Drainage- If the unit will or may be exposed to rain, snow or moisture the installer must account for how water will drain out of the fire ring. If adequate ring drainage is not accomplished, water will accumulate in the valve. Below is a suggestion how to provide weep holes in the ring. Drill ring and pan accordingly.

WARRANTY REQUIREMENT: Seal Center Hub- If your fire ring has a threaded center plug it is advised to seal this with a high temp sealer rated at 2000 degrees Fahrenheit or greater.

WARRANTY REQUIREMENT: Weep holes in pan- If not an HPC pan installer must ensure sufficient weep holes in pan to drain heavy rains positioned in a way that does not drain directly onto the valve box.

Fire ring and pan weep hole example

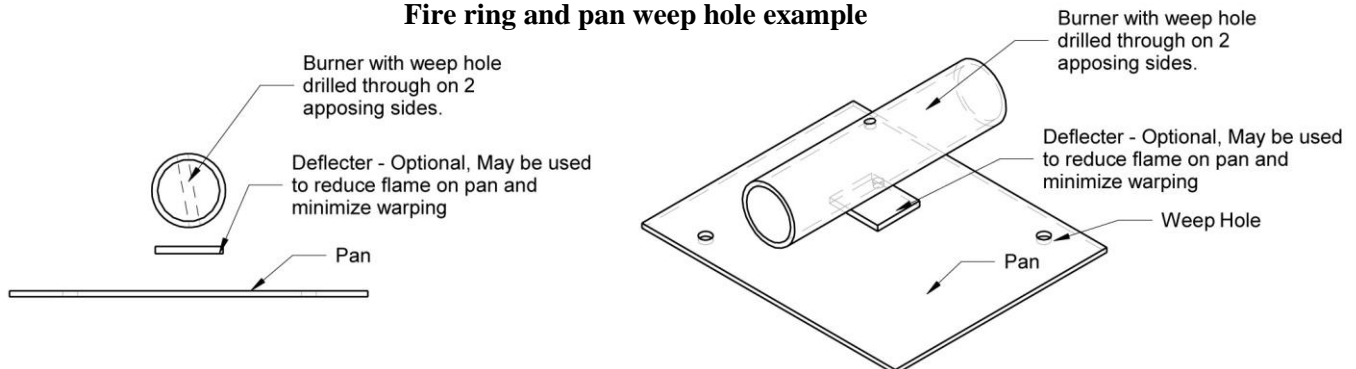

(Weep hole estimate for every 10 sq. feet of pan = 10 each - 1/4" functioning weep holes)

8) Fire Pit Operation

WARNING: Before use, be sure to test all gas connections for leaks. Do not use fire pit if there is any evidence of leaking gas. If leaking gas suspected, turn off the main gas supply and repair immediately.

WARNING: Wind and gusty conditions will affect the flame in an unpredictable manner. If conditions exist that are not safe for patrons turn the fire pit off.

WARNING: Do not use fire pit if any part has been submerged under water. Immediately call a qualified service technician to inspect the fire pit.

WARNING: For electronic ignition models power to fire pit must be turned off via wall switch or breaker when not in operation.

WARNING: Never use any material that is non-porous and holds moisture such as gravel, pebbles, river rock, etc. This material, when heated will cause the trapped moisture to boil and fracture unexpectedly. This material is not sufficiently porous to allow heated steam to readily escape which can break and cause personal injury or damage.

WARNING: Solid fuels shall not be burned in the fire pit. Leaves, sticks, wood, paper, clothing, food material, should be kept away from the fire pit. Make sure that there is no vegetation or other objects over the top or sides of the fire pit that could interfere with safe operation. (See clearances in section 2.)

WARNING: If lava rock is wet, allow fire pit to burn for 45 minutes prior to coming within 15 feet of the fire pit.

WARRANTY REQUIREMENT: When not in use the fire pit must be covered at all times.

FPPK Start Up

- 1) STOP! Read the safety information on “What to do if you small gas” (Pg. 1.)
- 2) Ensure fire pit is clear of people, debris, that all covers are removed and the feature is safe to start.
- 3) Turn “On” gas to fire pit.
- 4) Rotate has valve knob CCW to pilot light position.
- 5) Depress and hold the valve knob.
- 6) Turn “On” spark igniter by depressing switch in short burst until pilot lights.
- 7) Once lit, release switch for spark igniter while continuing to depress valve knob for 20 seconds.
- 8) Turn knob CCW to light main burner
NOTE: If fails to light, wait 5 more minutes for gas to clear. Repeat steps 3-8.
- 9) Never later the design of the fire pit.
- 10) Ensure fire pit, children and patrons are supervised by a responsible adult that is familiar with emergency shut down.
- 11) Flammable materials should not be placed on or near the fire pit.

This product is not for use with small tanks. It is intended to be connected to fixed piping systems only.

FIRE PIT SHUTDOWN

- 1) Turn “off” fire pit by slightly pressing and turning valve knob CW to “OFF” position.
- 2) Slightly push in and turn CW to extinguish pilot.
- 3) Turn “off” gas to fire pit.
- 4) After cooling cover fire pit.

9) Maintenance

WARNING: Any guard or protective device removed for servicing must be replaced prior to operating the fire pit.

WARNING: Installation and repair should be done by a qualified service person. Fire pits should be inspected prior to use and at least annually by a qualified service on.

WARNING: Ensure gas and power (if applicable) are shut off and fire pit is cool before servicing.

- Keep fire pit covered at all times when not in use.
- Keep any debris out of fire pit- clean as needed.
- In some areas of the country spiders or insects have been known to build nest and or lay eggs in the venturi holes of the air-mixer for LP units. This can cause fuel to fill the fire feature cavity and result in personal injury or property damage. Periodical inspection by a qualified service technician of the air-intake is required to ensure your fire feature performs properly.
- Ring cleaning: (1 x YR) If flames exhibit any abnormal shapes or behavior, or if burner fails to ignite properly, then the burner holes may require cleaning. The appliance can be cleaned by carefully removing the logs and media to allow access to burner. Use a brush to carefully remove dust, spider webs, and loose particles from base, logs, and fire ring itself. If evidence of damage, fire ring must be replaced with fire ring specified by manufacturer.
- Thermocouple cleaning of soot: (1 x 6 mos. or as needed) Remove lava rock & glass around pilot, then the blow out box lid. Clean thermocouple of any soot using soft brush. Be careful not to damage hot wire element. Place lava rock or glass back as explained in section 5.
- Visually inspect the pilot - The pilot flame should cover 3/8" to 1/2" of the thermocouple as shown below. Cleaning of orifice may be required by removing the pilot tube and removing orifice as shown below. Perform leak test on pilot tube after reassembly



We suggest that our products be serviced by a professional certified in the US by the National Fireplace Institute (NFI) as NFI Gas Specialists.

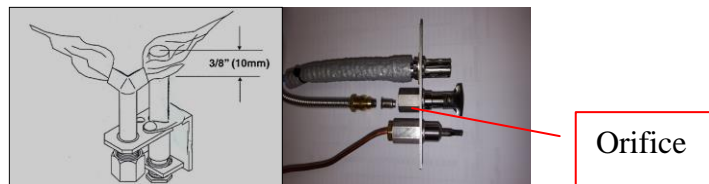
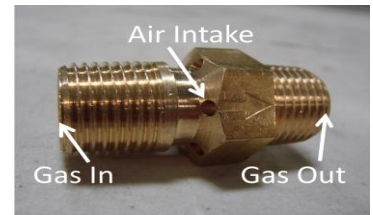

Installing/changing batteries to spark igniter unit in valve box:

- 1) Carefully unscrew the spark igniter unit cap as shown depending on your model.
- 2) Remove cap with battery as shown.
- 3) Remove old battery from cap, install new 9V battery
- 4) Holding by cap, slide battery into spark igniter unit as shown.
- 5) Tighten cap lightly- DO NOT over tighten.



10) Troubleshooting

Below are some potential causes and countermeasures to the symptoms indicated in bold. Please contact your retailer or certified technician for service & repair.

No Pilot Flame

- | | |
|--------------------------|--|
| 1. Air in gas line. | If new install, may take several attempts to purge air |
| 2. Debris in gas line. | Confirm gas line is clear (insulation, dirt, plastic etc.) |
| 3. Gas pressure improper | Confirm proper gas pressure (Section 1) |
| 4. Pilot orifice dirty | Remove pilot head and clean (Section 9) |

No Main Burner (Pilot Lights)

- | | |
|-----------------------------|---|
| 1. Gas pressure improper | Confirm proper gas pressure (Section 1) |
| 2. Small pilot flame | Remove pilot head and clean orifice. (Section 9) |
| 3. Dirty thermocouple | Clean using soft brush (Section 9) |
| 4. Fire ring obstructed | Confirm no debris or water in ring (Always cover fire pit!) |
| 5. Improperly applied media | See (Section 5) |

Main Burner Turning Off/On Frequently

- | | |
|-----------------------------|---|
| 1. Small pilot flame | Remove pilot head and clean orifice (Section 9) |
| 2. Improperly applied Media | See (Section 5) |
| 3. Gas pressure improper | Gas pressure too low (Section 1) |
| 4. Thermocouple defective | Change Thermocouple. |

11) Warranty

Limited Warranty

Hearth Products Controls Company (HPC) warranties HWI fire pits against manufacturing defects that prevent safe and correct function as follows:

- **Electronics, gas valve: Commercial-1yr; Residential- 3 yr.**
- **Pilot assembly: Commercial-1 yr.; Residential-2 yr.**
- **Stainless steel pan, fire ring and valve box: Commercial-1yr.; Residential 5yrs.**

This commences from the date of original sale / shipment from HPC FOB Dayton, Ohio.

This warranty is for parts and in-house (HPC) labor. The defective product must be sent back to HPC with a Return Merchandise Authorization (RMA) issued by HPC for that specific product and any other additional information for the nature of the defect or warranty claim.

The warranty does not cover items that have been damaged by overheating, modification, abuse, or improper storage. Also any labor involving installation or maintenance with the unit is not covered.

This warranty excludes claims for consequential, indirect-collateral expenses arising from product defects or warranty recovery.

**Figure 1 - Up to 200k BTU
For Outdoor Use Only**

REVISIONS				
ZONE	REV	DESCRIPTION	DATE	APPROVED

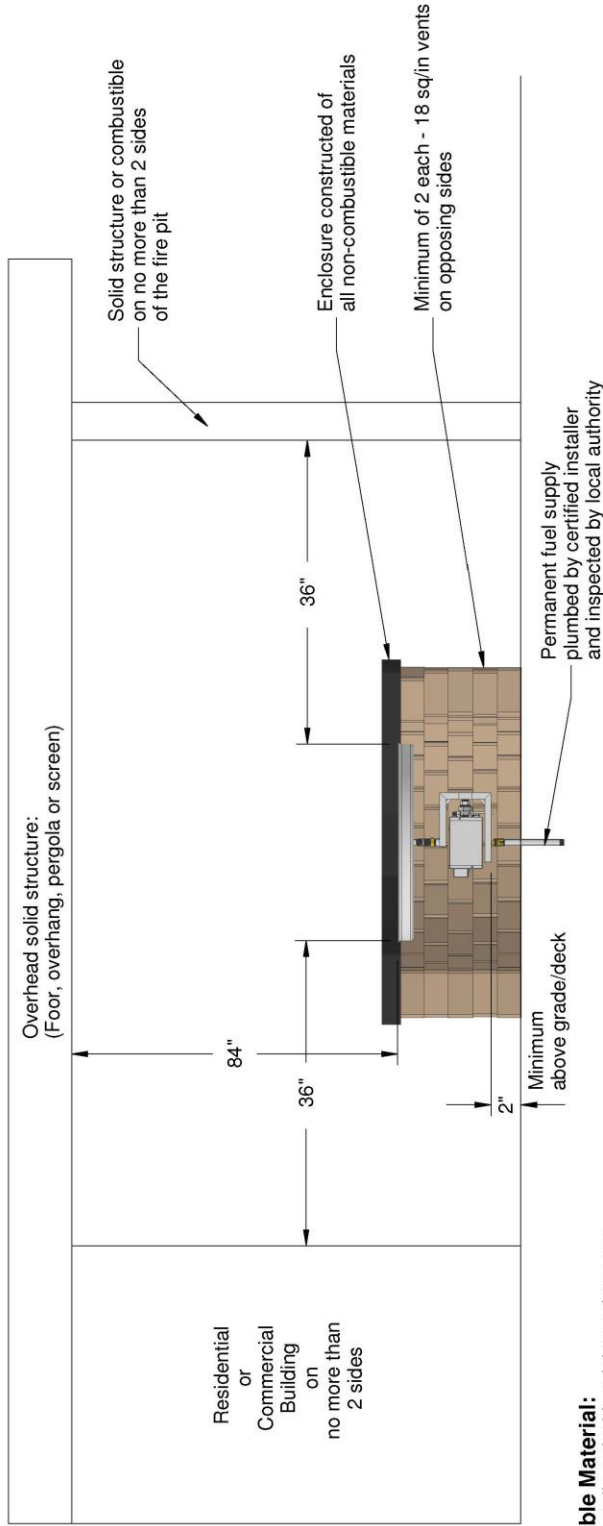

Residential or Commercial Building on no more than 2 sides

Combustible Material:

-For direct install on decking, joist and trusses see Deck Installation Kit drawing and instructions

Note:

- 50% free air space minimum. HPC is not responsible for screen that melts.
- For non-combustible screening a 20 x 20 x .013 wire mesh thickness or courser. (More open space)
- For all other non-combustible coverings an on-site estimate of free air space will be necessary.

Free Air Space Mesh Example

3:1 Scale of 20x20x.013

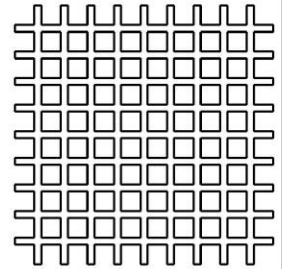



Diagram illustrates common clearance questions.	DRAWN	DATE	Clearance's - Standard Fire Pit Up to 200k btu	
* Clearance from overhead structure	CHECKED	4/24/2017	 Hearth Products Controls Co	
* Clearance from structure/combustible	QA			
All items may or may not apply to your project.	MFG		SIZE	REV
Clearance's apply to any and all sides of the project.	APPROVED		A	
Read and follow all instructions and local codes			SCALE	SHEET

