

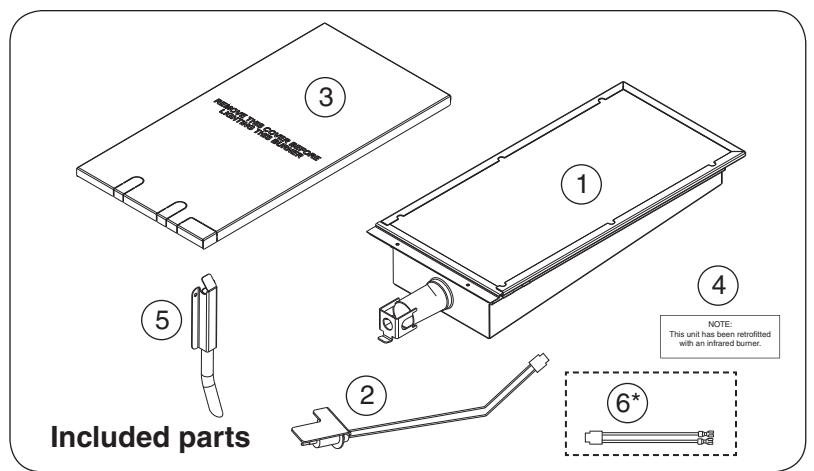

INFRARED BURNER KIT INSTRUCTIONS (HOT SURFACE IGNITION)

Model # 3050
3060



PARTS INCLUDED

1. Infrared burner
2. Electrode assembly
3. Burner cover
4. Label
5. Flash tube
6. Adapter wire*

TOOLS REQUIRED

- Phillips screwdriver
- Pair of needle-nose pliers
- 1/4" hex nut driver
- 3/8" hex nut driver

Table 1-1	Infrared Orifice Chart	
	Kit Model # 3050	Kit Model # 3060
	Grill Models: A530, A/E660, A/E790, E1060	Grill Models: A430, A540
Natural Orifice	3001-45	3001-49
Propane (L.P.) Orifice	3001-55	3001-56

* The adapter wire (item #6) is provided for use with Echelon grills that are equipped with igniter buttons for lighting. (Push to light configurations do not require this adapter.)

INSTALLATION

REMOVING THE OLD BURNER

1. Be sure the grill is completely cool and the gas is completely shut off. Open the oven lid.
2. Remove the cooking grid from above the burner by lifting it first from the front and set it aside (see Fig. 1-1).
3. Remove the flavor grid from above the burner and set it aside (see Fig. 1-1). The flavor grid will not be used with the infrared burner.
4. Remove the flash tube by removing the two hex nut screws using the 1/4" hex nut driver; pulling it directly away from the grill fire wall and off the mounting pin and the igniter electrode (see Fig. 1-2). Retain screws for installation.

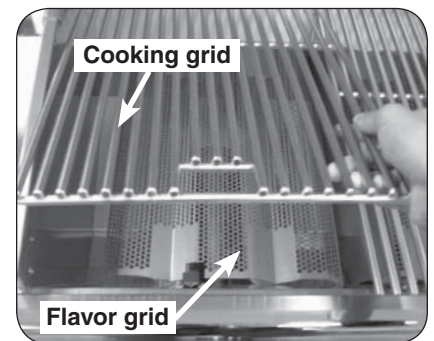

Fig. 1-1 Remove cooking and flavor grid

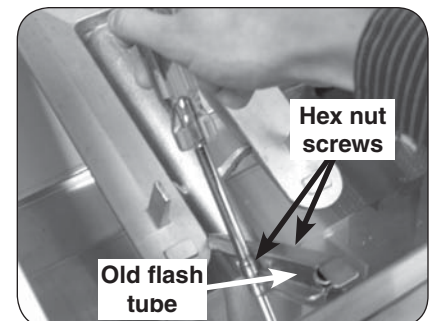

Fig. 1-2 Remove the flash tube

INSTALLATION (cont.)

- Remove the cotter pin from the right rear burner anchoring peg using needle-nose pliers. Pull it straight out of the cotter pin hole (see Fig. 2-1).

CAUTION: The burner is heavy.

- Remove the existing main burner by lifting the pegs extending from under the back end of the burner out of the two (2) holes on the bottom of the oven. After the pegs have been freed, move the whole burner toward the back of the grill so that the burner gas intake pulls away from the gas orifice at the front fire wall of the grill (see Fig. 2-2). Then carefully lift the burner out and set it aside. Retain the clip with the burner so that they can be re-installed in the future if desired.
- The grill is equipped with a heatshield kit for each main burner. This kit is only functional with the standard main burner, and must be removed for proper infrared burner operation. Use pliers to remove the diverter tube by bending in each side and pulling it outwards (see Fig. 2-3), then reach in and remove the silicone gasket (see Fig. 2-4).

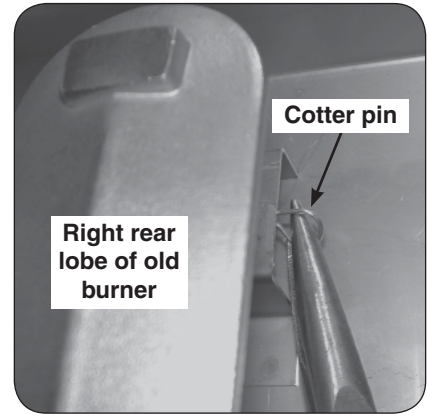

Fig. 2-1 Remove the cotter pin

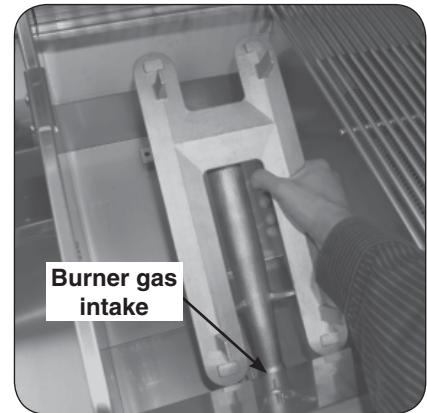

Fig. 2-2 Remove the burner

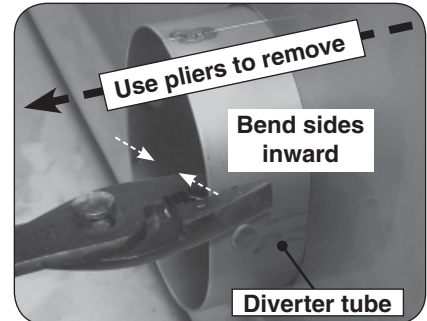

Fig. 2-3 Remove diverter tube

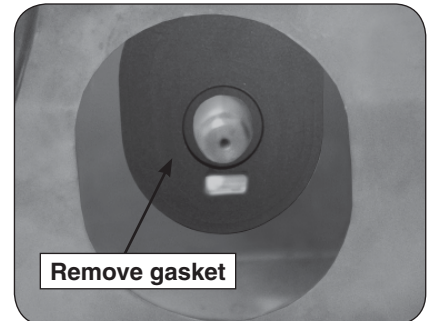

Fig. 2-4 Remove silicone gasket

INSTALLING THE NEW INFRARED BURNER

1. Use the $\frac{3}{8}$ " hex nut driver to remove the exposed gas orifice and replace it with the correct orifice for the new infrared burner included with your kit (See Table see 1-1. See also Fig. 3-1, 3-2 and 3-3).

Note: You may need to lean over the oven and look back toward the inside front of the grill to see the orifice.

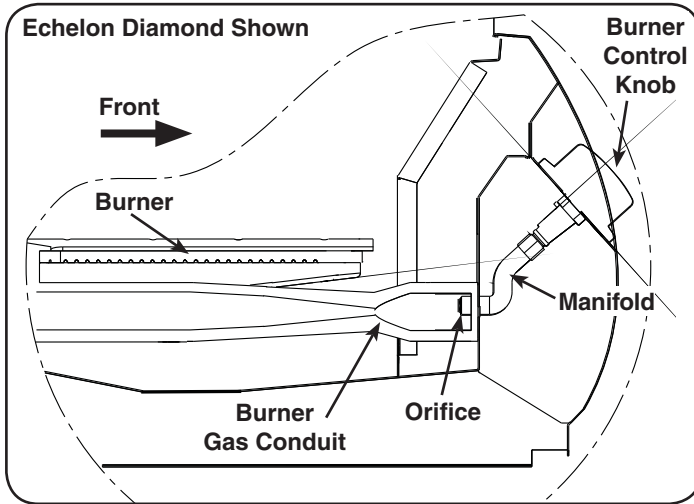

Fig. 3-3 Orifice location cut away side view

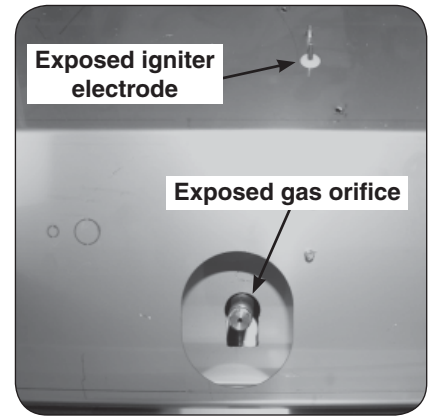

Fig. 3-1 Locate the gas orifice



Fig. 3-2 Replace the gas orifice

INSTALLATION (cont.)

2. Remove the control panel. Refer to the owner's manual included with your grill.
3. Disconnect the existing electrode wires from the wires attached to the wire harness.
4. To remove the heat shield, first cut the zip ties. Then lift the heat shield up and inward slightly to clear the diagonal slots hooked over the oven fire wall then pull away from the manifold (see Fig. 4-1).
5. Install the infrared burner by first sliding it over the orifice, then line up the two tabs in back of the burner with the two slots in the back of the grill and lower them carefully into place (see Fig. 4-2).

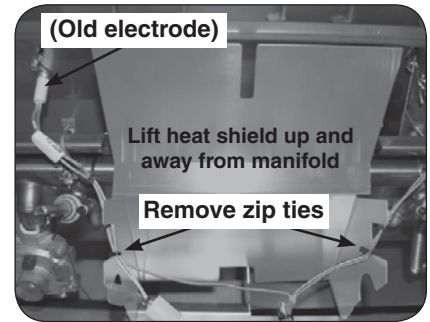

Fig. 4-1 Remove heat shield



Fig. 4-2 Install new burner

INSTALLATION (cont.)

6. Carefully remove the punch-outs located in the forward firewall (see Fig. 5-1).
 7. Slide the infrared electrode wire into the large punch-out hole. Secure in place through the small punch-out with the screw and nut provided (see Fig. 5-2 and see 5-3).
 8. Feed the infrared electrode wire through the hole in the manifold firewall and heat shield.
 9. Connect the wire to the available wire harness connector that was previously used to connect the old electrode (Fig. 5-3). Test the igniter by pressing the corresponding control knob (or igniter button) and observing that the tip of the igniter glows orange.
- Note:** On select Echelon grills, the adapter wire (provided) will need to be used to connect the new electrode wire to the main harness wire.
10. Apply the conversion label supplied with this kit to the inside of the fire wall behind the control panel so that it does not obscure any other labels.
 11. Reposition the heat shield by hooking the diagonal slots back over the sheet metal of the manifold fire wall.
 12. Using a 1/4" hex nut driver, replace the old flash tube with the one provided in this kit (see Fig. 5-4).
 13. Remove the appropriate punch-outs (on the protective cover) for your burner and location. Place the cover on the infrared burner. (See Fig. 6-1.)
 14. Reinstall the control panel.
 15. Replace the cooking grid so that the cut-out section of the grid is in front.

Note: FLAVOR GRIDS ARE NOT TO BE USED with infrared burners.

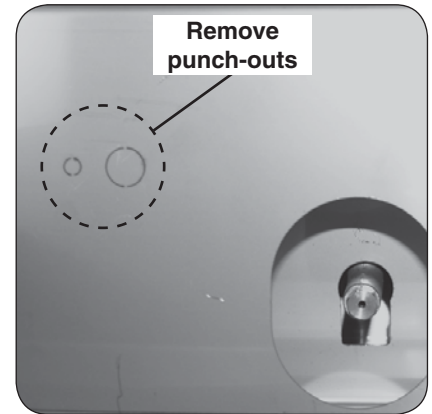

Fig. 5-1 Remove Punch-outs



Fig. 5-2 New electrode

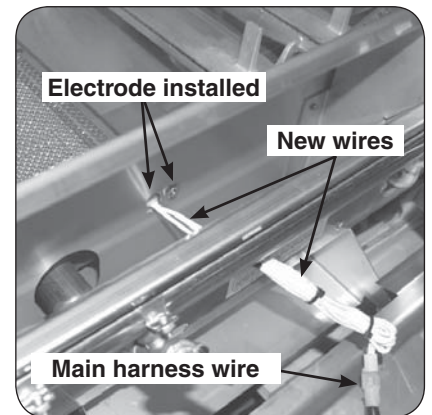

Fig. 5-3 Connect new electrode wires

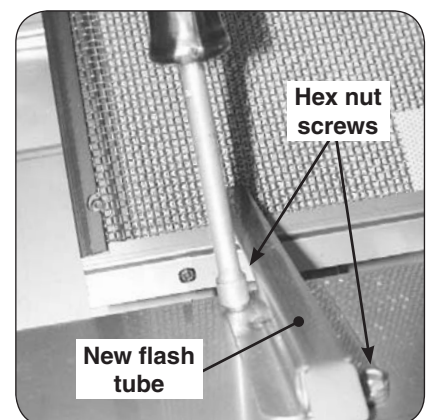
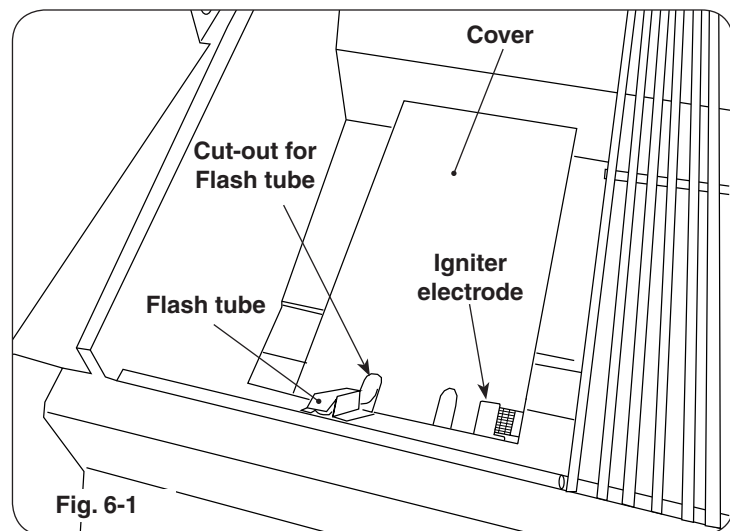

Fig. 5-4 Replace the flash tube

INFRARED BURNER OPERATION

The infrared (IR) searing burner (optional) cooks with a powerful radiant heat.



WARNING

Only handle the infrared burner cover when the unit is cold or with a well-insulated long-handled tool or heat resistant gloves.

SIDE VIEW (with cover on)

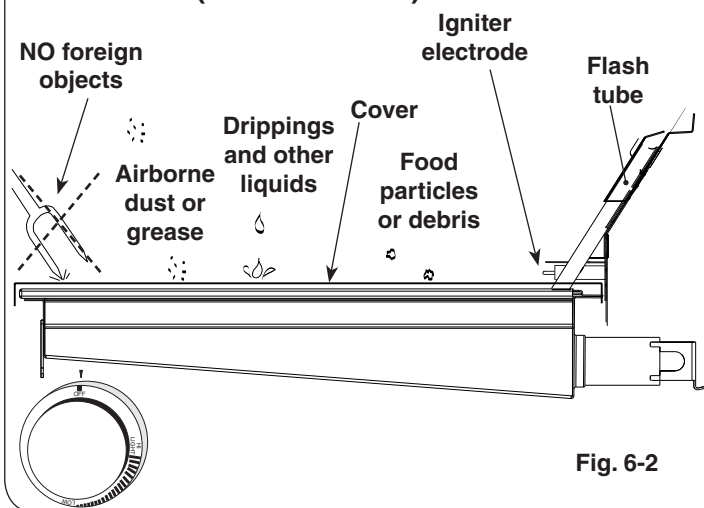

Light the infrared burner following the LIGHTING INSTRUCTIONS in this manual or printed on the drip tray. Follow these guidelines when operating the Infrared burner:

- **DO NOT** place food on the cooking grid until the IR burner glows orange (Fig. 6-3). Drippings are heated and evaporate instead of sticking to and impairing burner function.
- **For cleaning purposes; always leave your burner on (after cooking) for an additional 5 minutes, to allow for a burnoff period. This is important to keep your burner clean and operating properly. As the burner is self cleaning (at full temperature); avoid the use of cleaners or abrasives.**
- When not in use, **always** cover the infrared burner with the stainless-steel cover. This protects the burner from drippings (from other cooking), airborne particles, and foreign objects (Fig. 6-2).
- Do not strike or scratch the burner ceramic as it may chip, crack, or break (Fig. 6-2).

Note: Digital thermometer does not give accurate readings for infrared burners.

Important: When grilling with the infrared burner, always place a cooking grid above it. The cooking grid must be removed for rotisserie cooking.

CAUTION: DO NOT operate your IR burner with the oven hood closed.

CAUTION: Never attempt to operate the IR burner with the protective cover in place.

Burner ceramic must be protected with cover when burner is not in use.

SIDE VIEW (burner on HI LIGHT and glowing orange)

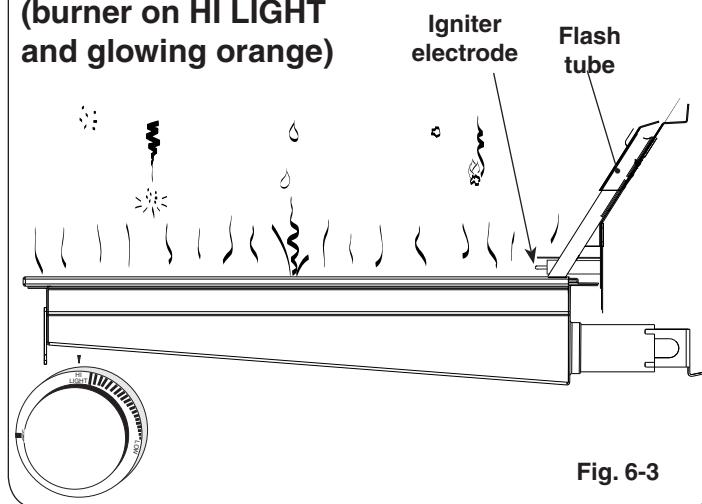

Drips and particles evaporate before hitting infrared burner when cooking at the maximum setting.

Note: Flavor grids are not to be used with infrared burners.

To ensure proper operation, all infrared burners (back and main) must be operated on the HI setting for a minimum of 10 minutes. Thereafter, the flame may be lowered as desired.

CAUTION: Always monitor the infrared burner flame when operated on low, as it may blow out in high-wind conditions.