



CHARCOAL POST OUTDOOR GRILL

22 Series (In-ground and patio mount)

INSTALLATION AND OWNER'S MANUAL

INSTALLER: Leave these instructions with consumer.
CONSUMER: Retain for future reference.



IMPORTANT: READ THESE INSTRUCTIONS CAREFULLY BEFORE STARTING INSTALLATION OR USE.

SAFETY AND WARNING CODES

⚠ WARNING:
Do not store or use gasoline or other flammable vapors and liquids, including propane cylinders, in the vicinity of this or any other appliance.

ONLY TO BE USED OUTDOORS

⚠ WARNING:
Improper installation, adjustment, alteration, service, or maintenance can cause injury or property damage. For proper installation, refer to the installation instructions. For assistance or additional information, consult a qualified professional service technician, or service agency.

CODE REQUIREMENTS: This grill must be installed in accordance with local codes and ordinances.

WARNING: All surfaces of the charcoal unit become **HOT** during use. Exercise caution when using this unit, especially when adding charcoal or cranking the charcoal pan up or down. Wear heat-resistant gloves as necessary.

Proper operation of your grill requires prompt and periodic maintenance. See the **SERVICING AND CLEANING section for details.**

Cooking Grid U.S. Patent Nos. D857,453 D862,984

GETTING STARTED

INSTALLATION, OPERATION, AND SAFETY INFORMATION 3
INSTALLATION REQUIREMENTS 4
 OVERHEAD CONSTRUCTION REQUIREMENTS..... 4
 REAR WALL CLEARANCES 5
DIAGRAMMATICAL REPRESENTATIONS OF OUTDOOR AREAS 6
MODEL SPECIFICATIONS 7
REPLACEMENT PARTS LIST 9

INSTALLATION

PATIO MOUNT INSTALLATION 10
IN-GROUND POST INSTALLATION 11
COMMON INSTALLATION..... 12
 INSTALL CRANK 12
 INSTALL DRIP TRAY 12
 INSTALL COOKING GRIDS 13
 INSTALL RIGID SHELVES 13
USING THE GRILL 14

USE, CARE, & SERVICE

OPERATION 15
 CHARCOAL INSTRUCTIONS..... 15
 CHARCOAL SHIELD 15
 AIR SHUTTERS 15
SERVICING AND CLEANING 16
 CLEANING YOUR GRILL..... 16
 FACE REMOVAL..... 18
TROUBLESHOOTING..... 19
WARRANTY 20

INSTALLATION, OPERATION, AND SAFETY INFORMATION

1. The outdoor appliance and surrounding area **MUST** remain clear of flammable substances such as gasoline, yard debris, wood, etc. Maintain a minimum horizontal clearance of 18" (50 cm) (in all directions) from combustible materials/items.
2. Clean the drip tray frequently to minimize grease build-up. Excessive grease deposits can result in a grease fire.
3. Wear gloves and use extreme caution whenever installing and handling this product and its accessories as certain components have sharp edges that can cause personal injury.
4. Adults **MUST** be present when this cooking appliance is operating. This appliance **MUST NOT** be left burning when unattended.

IMPORTANT

IN THE EVENT OF A GREASE FIRE, IMMEDIATELY CLOSE THE OVEN LID, MOVE TO A SAFE DISTANCE, AND ALLOW THE FIRE TO EXTINGUISH ITSELF.

WARNING: NEVER cover more than 75% of the cooking or grill surface with griddles, pots, or pans. Overheating will occur and will not perform properly when combustion heat is trapped below the cooking surface.

**The grill serial number tag can be found affixed behind the face (on a thermal label).
See the FACE REMOVAL section to gain access.**

INSTALLATION REQUIREMENTS

Installation must be performed by a qualified professional service technician.

This unit is designed for outdoor use only. **DO NOT** use this unit inside a building, garage, or enclosed area, or under overhead **combustible** construction. **DO NOT** install this unit in or on a recreational vehicle or boat.

Any constructed outdoor area in which the appliance is used shall comply with one of the following:

- An outdoor area with walls on three sides, and no overhead cover
- Within a partial outdoor area that includes an overhead cover and no more than two walls. The sidewalls may be parallel, as in a breezeway, or at right angles to each other
- Within a partial outdoor area that includes an overhead cover with walls on three sides, and at least 30% or more of the horizontal periphery of the enclosure that is open and unrestricted

Note: All openings must be permanently open.

Note: Sliding doors, garage doors, windows, or screened openings are not considered as permanent openings.

Refer to DIAGRAMMATICAL REPRESENTATIONS OF OUTDOOR AREAS section.

OVERHEAD CONSTRUCTION REQUIREMENTS

Important: **DO NOT** use this appliance under combustible overhead construction.

A minimum 5 foot (1.5 meters) clearance is required between the cooking surface and the non-combustible overhead construction. (No combustible materials are allowed within this area.)

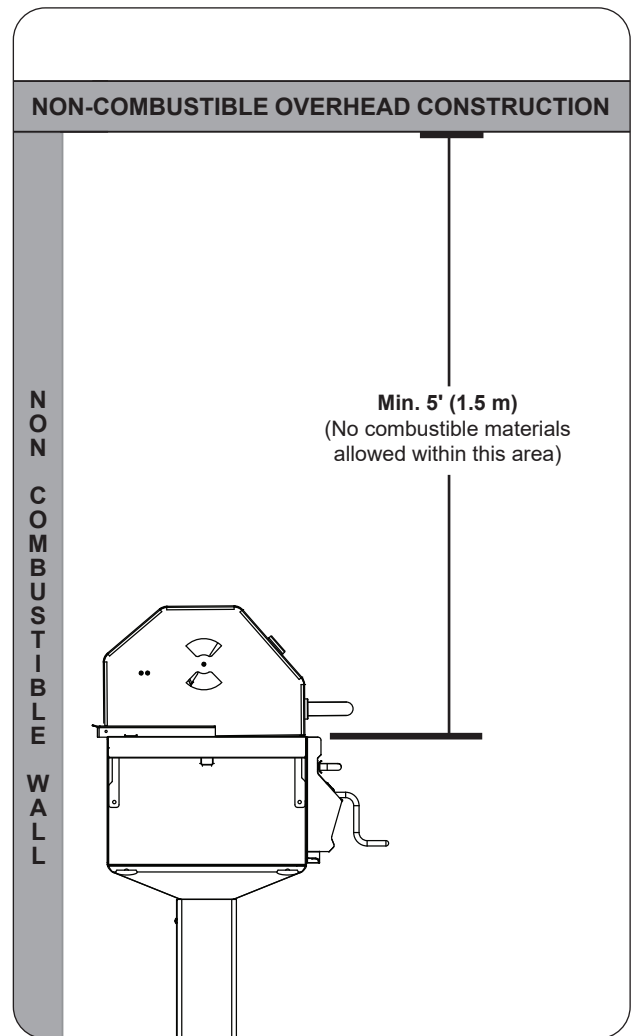

Fig. 4-1 Overhead requirements

INSTALLATION REQUIREMENTS (Cont.)

Important: The grill is not insulated. Refer to the information below to ensure all required clearances are met.

REAR WALL CLEARANCES

For the minimum clearances between the unit and rear walls, your setup must fall within one (or more) of the following:

A. Clearance between unit and strictly non-combustible rear wall

(i.e. brick wall, see Fig. 5-1)

- The unit must have a minimum clearance of 11" (28 cm) from the non-combustible rear wall.

(To allow for proper ventilation and prevent dangerous overheating.)

B. Clearance between unit and combustible rear wall

- The unit must have a minimum clearance of 18" (46 cm) from the combustible rear wall (see Fig. 5-2).

SIDE / CORNER WALL CLEARANCES (if applicable)

The unit must have a minimum clearance of 24" (61 cm) from any side walls (to account for variables in airflow that could affect performance). See Fig. 5-3.

IN-GROUND POST CORROSION REQUIREMENTS

In-ground metallic posts must be protected against corrosion as warranted by soil conditions. The stainless-steel post offers some protection against corrosion; however, the installation may require additional protection. Corrosion protection must be provided as needed with a suitable coating to retard the effects of corrosion conditions existing in your local area.

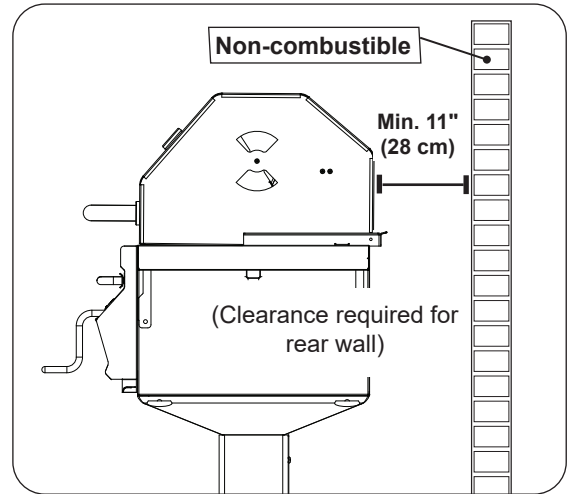

Fig. 5-1 Clearance 'A' Diagram

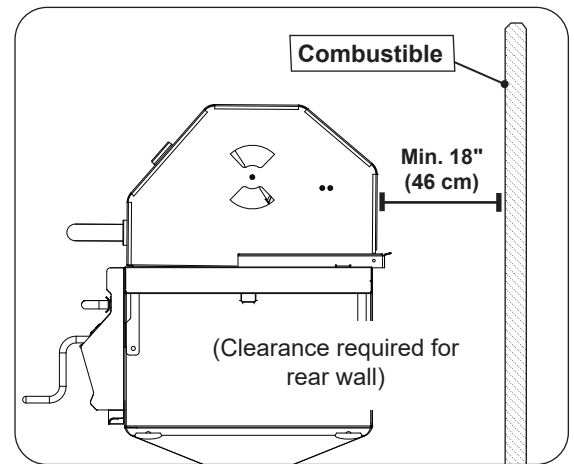

Fig. 5-2 Clearance 'B' Diagram

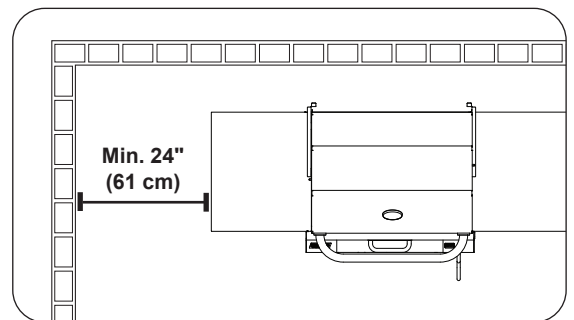

Fig. 5-3 Side/corner wall clearance

DIAGRAMMATICAL REPRESENTATIONS OF OUTDOOR AREAS

The following figures are diagrammatical representations of outdoor areas, as defined in Clause 4.25.3. See INSTALLATION REQUIREMENTS section.

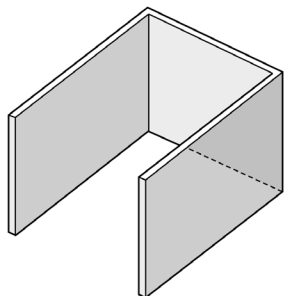

Fig. 6-1 Outdoor area - Example 1

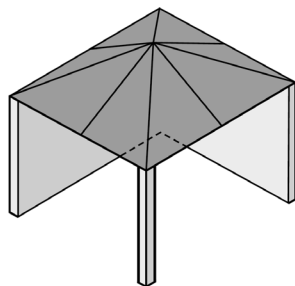
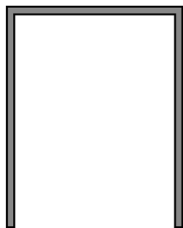

Fig. 6-2 Outdoor area - Example 2

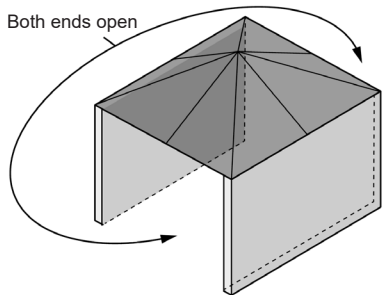
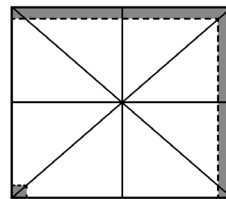

Fig. 6-3 Outdoor area - Example 3

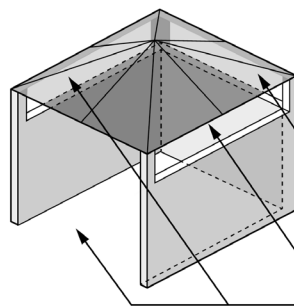
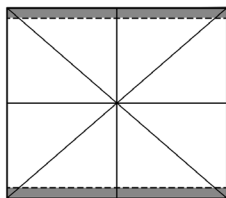
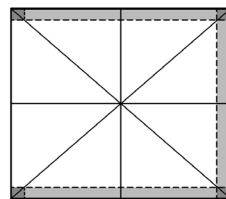

Fig. 6-4 Outdoor area - Example 4



30% or more of the horizontal periphery of the enclosure is open and unrestricted

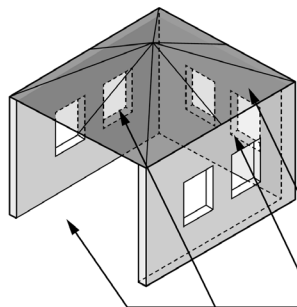
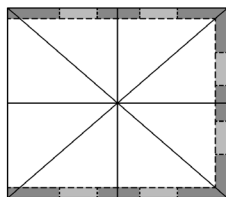

Fig. 6-5 Outdoor area - Example 5



30% or more of the horizontal periphery of the enclosure is open and unrestricted

MODEL SPECIFICATIONS

Height			Width		Depth	
Floor to top (with oven)		Floor to top of shelf (C)	Left to right		Front to back	
Open (A)	Closed (B)		Post base (D)	Shelves (E)	Post base (F)	Maximum outer (G)
60 1/4" (153 cm)	49 1/4" (125.1 cm)	37" (94 cm)	26" (66 cm)	55 1/2" (141 cm)	20 1/4" (51 cm)	29" (73.7 cm)

Table 1 - Post Patio Mount Grill Dimensions

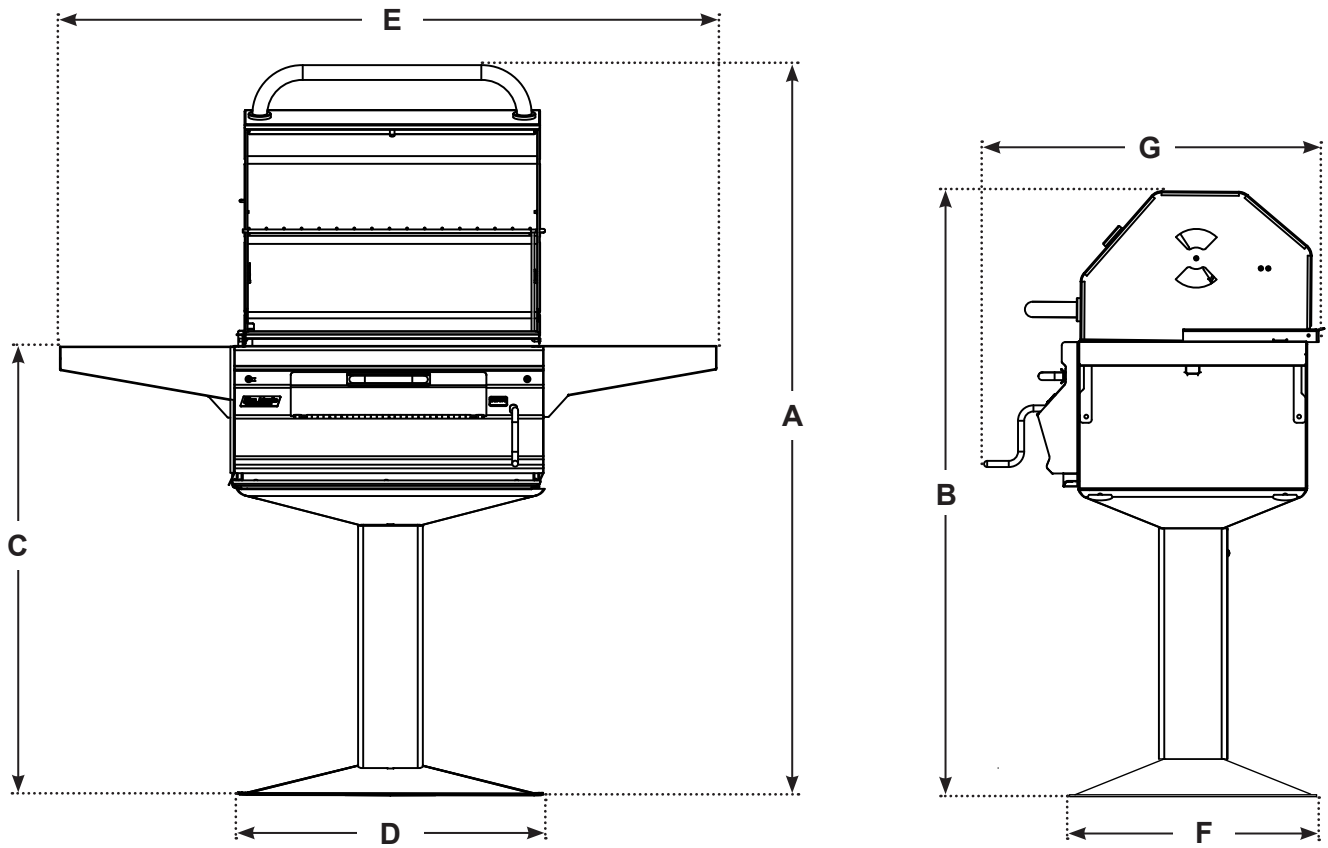

Fig. 7-1

MODEL SPECIFICATIONS (cont.)

Height*				Width		Depth	
Floor to top (with oven)		Floor to top of shelf (J)	Floor to bottom of extension below ground (K)	Left to right		Front to back	
Open (H)	Closed (I)			Post (L)	Shelves (M)	Post (N)	Maximum outer (O)
60 1/4" (153 cm)	49 1/4" (125.1 cm)	37" (94 cm)	18" (45.7 cm)	5 1/2" (14 cm)	55 1/2" (141 cm)	5 1/2" (14 cm)	29" (73.7 cm)

*Note: Height dimensions are approximate from ground level once installed.

Table 2 - In-Ground Post Grill Dimensions

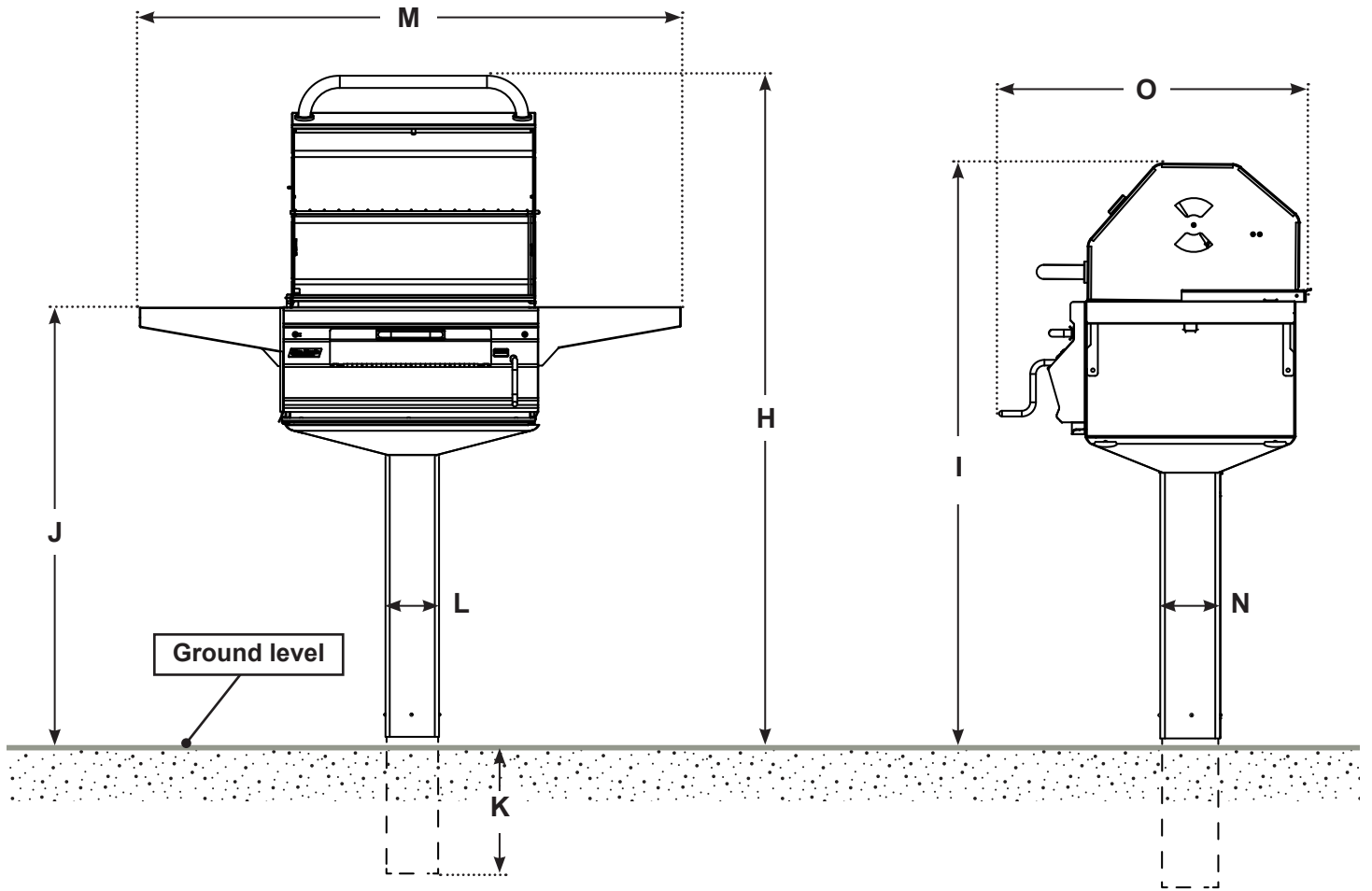

Fig. 8-1

REPLACEMENT PARTS LIST

		22 Series	
Item	Description	Part No.	Qty.
1.	Stainless cooking grid (set of 2)	3542-DS-2	1
2.	Smoking oven hood	23756-C	1
3.	Shelf rigid (set of 2)	25326-0171	1
4.	Face	3137-06	1
5.	Drip tray assembly	3081	1
6.	Patio mount post base w/ hardware*	24330-34	1
or	In-ground post base w/ hardware*	24330-35	1
7.	Patio mount hardware kit (if applicable)	24330-25	1
8.	Charcoal pan with charcoal screen	3302-S	1
9.	Charcoal screen only	3302-S-02	1
10.	Warming rack	3672C	1
11.	Handle only	3900-40	1
12.	Crank	23302	1
13.	Charcoal shield	3305	1
14.	Grid lifter	3519	1

IMPORTANT
Remove all packing material and discard prior to lighting.

To order replacement parts, contact your local Fire Magic® dealer.

* For replacement only (not conversion)

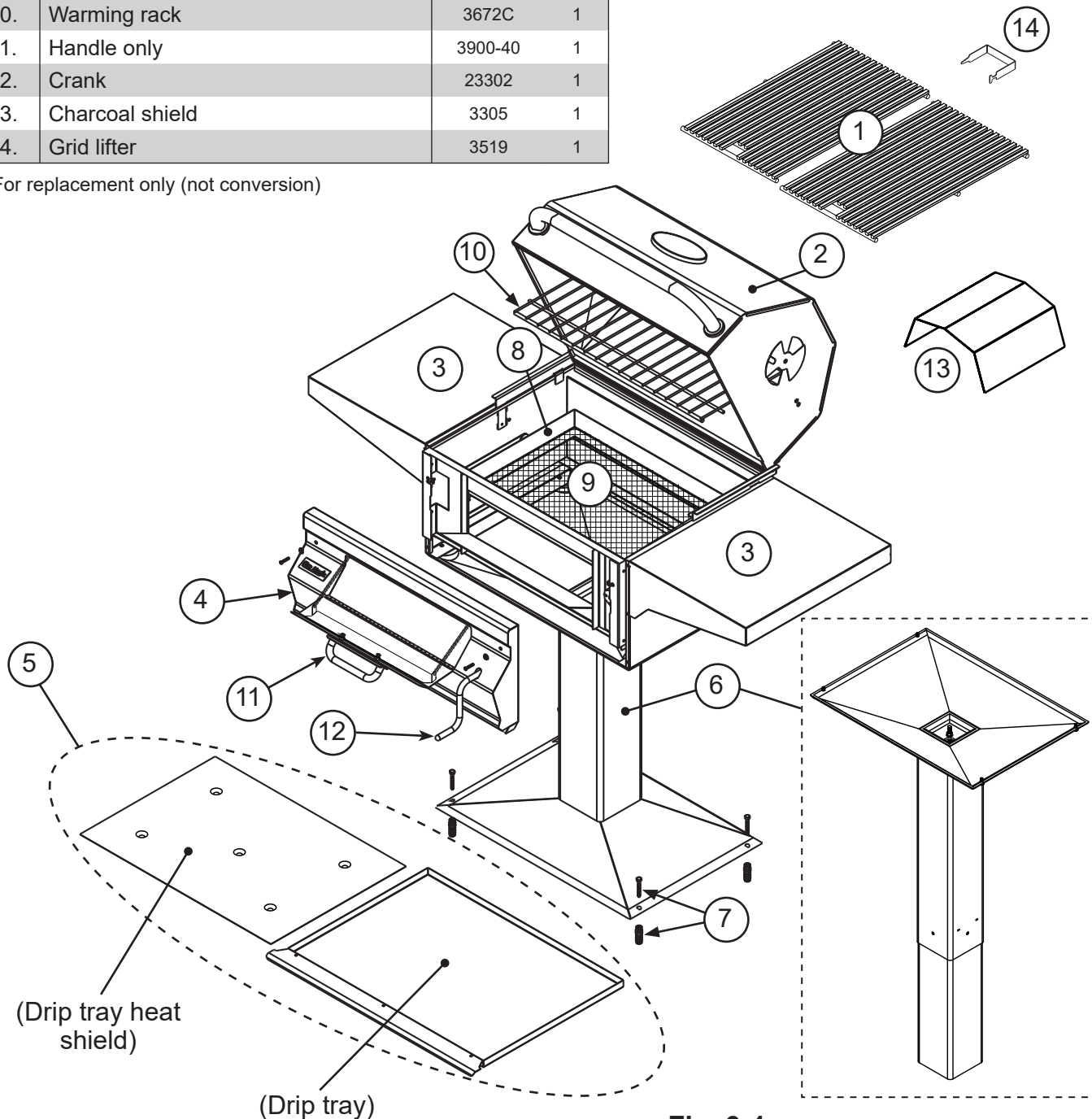

Fig. 9-1

PATIO MOUNT INSTALLATION

It is not required to remove the face to install this unit.

DO NOT lift the unit from the face when installing.

Consult a qualified professional installer.

SECURE PATIO MOUNT GRILL

Important: **BEFORE USE**, the patio mount base must be securely fastened to a stable, level surface to ensure the grill remains fixed and upright at all times.

Locate the patio mount base in the planned grill location and mark the 4 holes. Drill the marked holes to a 1/2" (1.3 cm) diameter x 1 1/2" (3.8 cm) depth. Insert the lag shields (see PARTS LIST) into the holes, being sure that they are flush with the ground.

Align the holes on the patio mount base over the lag shields in the ground. Secure the base with the lag screws (see PARTS LIST) using a 7/16" nut driver.

Proceed to the **COMMON INSTALLATION** section.

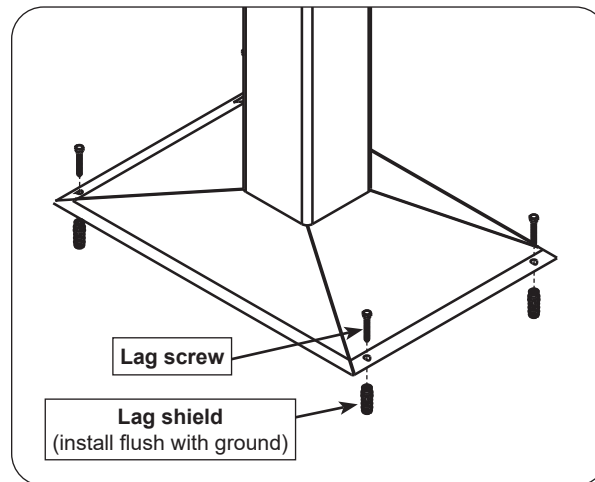

Fig. 10-1 Secure patio mount base

IN-GROUND POST INSTALLATION

It is not required to remove the face to install this unit.

DO NOT lift the unit from the face when installing.

Consult a qualified professional installer / licensed contractor.

ATTACH POST EXTENSION

1. Attach the extension to the bottom of the grill post so that the open portion is toward the back of the grill and the five holes in the extension line up with the five (5) weld-nuts in the post (see Fig. 11-1).
2. From outside the joined post and extension, insert one of the 1/4"-20 X 5/8" bolts (supplied) into each of the five (5) bolt holes and tighten each using a 7/16" socket driver or wrench (see Fig. 11-2).

Note: There is one hole on each side of the post, except the back which has two holes located on either side of the extension opening.

PLACE POST IN-GROUND & POUR CONCRETE

1. Dig a hole for the post and extension approximately 18" (46 cm) deep and 10-12" (25.4 cm-30.5 cm) in diameter.

Note: The actual depth of the hole should be such that the cooking surface is 37" (94 cm) above ground level.

2. Prepare the concrete to be used for the install.
3. Pour the concrete into the hole 3-5" (7.6cm-12.7 cm) below ground level.
4. While the concrete is still wet, carefully lower the extended grill post into the hole (see Fig. 11-3).
5. Orient the grill per plan, then level the grill and support it so that it remains in position while the concrete dries.

Note: It may be necessary to install the shelves at this point to assist in holding the grill level and in place as the concrete dries. See the INSTALL THE RIGID SHELVES section.

Proceed to the **COMMON INSTALLATION** section.

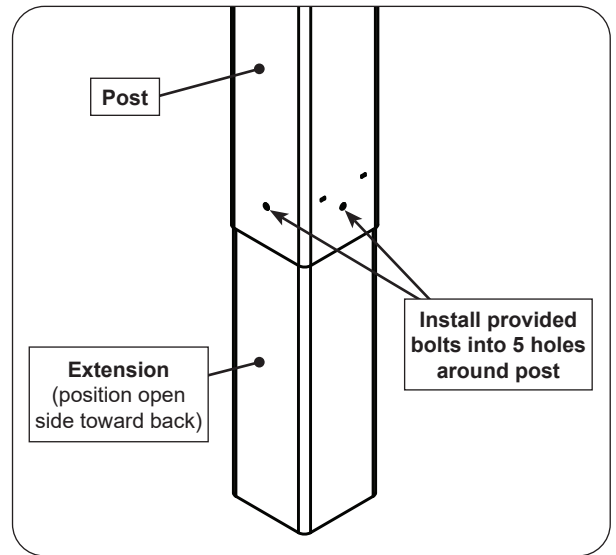

Fig. 11-1 Install extension to post

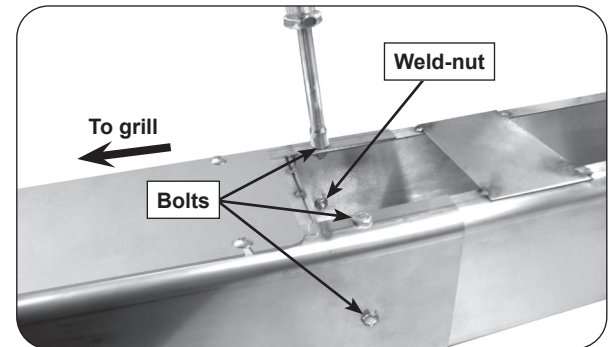

Fig. 11-2 Fasten extension to post

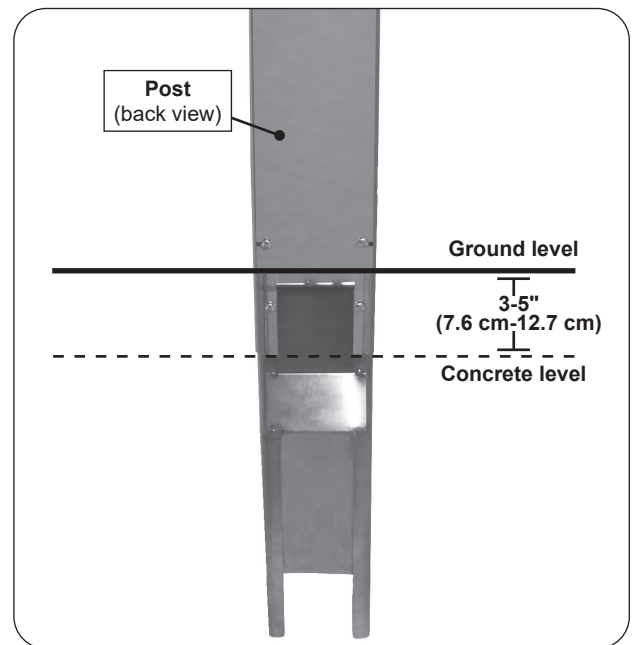

Fig. 11-3 Pour concrete & install post

INSTALL CRANK

Fit the crank handle into the hole on the front right side of the face. Aligning it carefully, screw it into the nut on the frame. After installation, crank the handle in and out to raise and lower the charcoal pan. See Fig. 12-1.

Note: The access door must be closed for the crank to raise the lifter to the highest position.

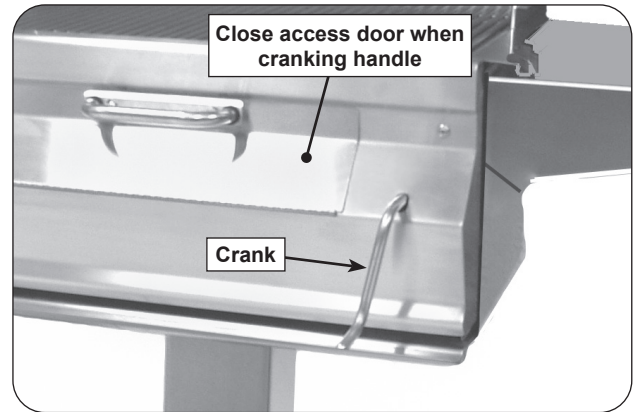

Fig. 12-1 Install crank

INSTALL DRIP TRAY

1. Place the heatshield inside the drip tray **with the dimples facing downward** (See Fig. 12-2).
2. Carefully lift the drip tray assembly with both hands. Keep the tray level and slowly insert the tray into the front opening of the grill.

INSTALL CHARCOAL PAN

1. Locate the charcoal grid and carefully place it inside the charcoal pan.
2. Take the tray with grid, carefully orient it inside the grill, and rest it on the cranking frame. See Fig. 12-3.

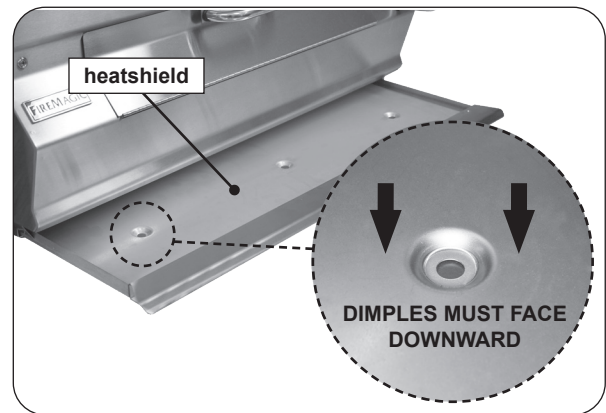

Fig. 12-2 Install drip tray

INSTALL WARMING RACK

1. Carefully insert the right-end of the warming rack into the bracket found on the right side of the inner hood (see Fig. 12-4, A).
2. Slide the left-end of the warming rack downward into the left bracket cutout (see Fig. 12-4, B).
3. Install the two legs to the two holes found on the grill firebox inner walls (see Fig. 12-4, C).

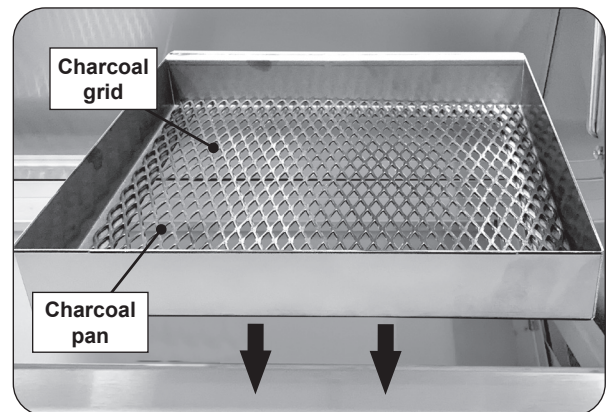

Fig. 12-3 Install charcoal pan

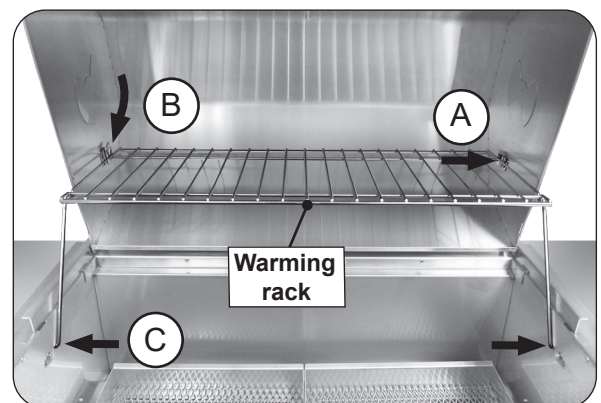

Fig. 12-4 Install warming rack

INSTALL COOKING GRIDS

Important: Do not leave the lifter on any hot surfaces.

1. With the prongs facing downward, insert the notched-end of the lifter between two grid rods, then rotate, as shown in Fig. 13-1, A & B.

Note: To balance, insert the notched-end of the lifter in the middle front half of the cooking grid.

2. Insert the rear pointed-end of the lifter between the same two rods (Fig. 13-1, B) and carefully lift the cooking grid and place onto the front and rear grid rests of the grill (see Fig. 13-2). Repeat for all other cooking grids.

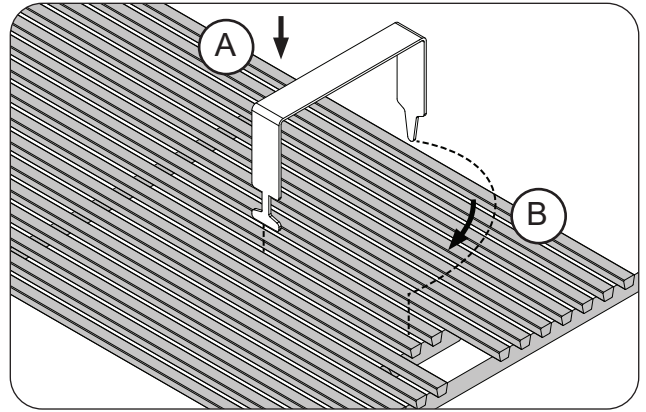

Fig. 13-1 Grid lifter

INSTALL RIGID SHELVES

This grill comes with two (2) rigid shelves that must be attached. These can be attached using the four support screws provided and a Phillips-head screw driver.

Important: Take caution to not cross-thread when tightening the screws.

3. Hold the shelf inverted so that one of the corner holes in the shelf lines up with the appropriate upper screw hole in the grill.
4. Insert the screw, but do not tighten all the way so that the shelf can be easily rotated around the first screw.
5. Line up the second corner hole in the shelf with the remaining upper screw hole in the grill. Insert a screw and tighten.

Note: You may lift the edge of the shelf upward to gain better access during much of the tightening of this screw.

6. Finally, insert the bottom screws on the left and right side of the shelf and securely tighten all screws.

To detach, reverse the process above.



Fig. 13-2 Install cooking grids

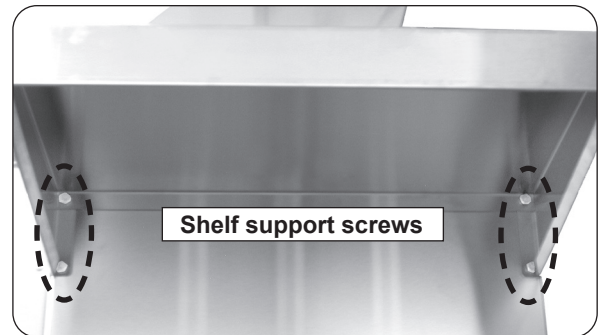

Fig. 13-3 View from under right shelf

USING THE GRILL

BEFORE INITIAL USE

Ensure that:

- the grill has been properly installed by a qualified professional service technician as instructed in this manual.
- you have read and understand all of the information in this manual.

BEFORE EACH USE

Ensure that:

- the surrounding area of the unit is clear and free at all times.
- the cooking area and drip tray are clean, and the drip tray is properly installed.

OPERATION

- **The grill becomes HOT during use, INCLUDING THE CHARCOAL ACCESS DOOR HANDLE AND CRANK. NEVER touch any part of the cooking area or surrounding hot surfaces with bare hands. Use long-handled insulated BBQ tools and wear an insulated glove / oven mitt.**
- **Always keep your face and body as far from the grill as possible during use. Avoid wearing loose-fitting clothing as they could ignite.**
- **This appliance is designed as an attended appliance. DO NOT leave this appliance burning when unattended.**
- **NEVER cover more than 75% of the cooking or grill surface with griddles or pans to prevent overheating.**

After reading and understanding all bullets above, follow these steps to light and use your grill:

1. Load, light, and adjust the charcoal per the OPERATION section.
2. Allow the grill to preheat until the desired cooking temperature is reached.
3. Place the food on the grill and cook as desired. Monitor the charcoal and adjust the grilling heat if necessary (see the CHARCOAL PAN section on the following page).
4. See the section below and the following pages for all other information regarding use.

AFTER EACH USE

1. Brush the cooking grids to remove all residue.

CAUTION: Use long-handled insulated BBQ tools and wear an insulated glove / oven mitt.

2. It is recommended to operate with high heat and hood closed for 10-15 minutes to burn off all grease.
3. Cover the grill once it has completely cooled.

Note: For additional cleaning, refer to the SERVICING AND CLEANING section.

OPERATION

Simple to use, this elegant stainless-steel charcoal grill has the added benefit of an adjustable charcoal pan to allow you to change the height of the charcoal while cooking, and gives you the ability to add fuel without having to remove the cooking grids. This enables the outdoor chef to be in complete control of the cooking heat at the grilling surface.

CHARCOAL INSTRUCTIONS

1. Remove the cooking grids and pile your charcoal on the charcoal pan. Avoid spillage.

WARNING: When adding charcoal, spread it across the charcoal pan evenly and DO NOT exceed a height of 1" (2.5 cm) above the charcoal pan. Excessive amounts of charcoal may cause over heating and damage to your grill.

2. Follow the instructions supplied with your charcoal/fuel for lighting.
3. Use the access door to add or spread out your coals while cooking.

CAUTION: Use long-handled insulated barbecuing tools to prevent burns from hot metal or coals.

4. Turning the crank handle raises or lowers the charcoal pan to increase or decrease the grilling heat as needed.

CHARCOAL PAN

The charcoal grill has an adjustable tray that allows you to change the charcoal height while cooking, and add fuel without having to remove the cooking grids.

Use the access door to add or spread out the coals while cooking (Fig. 15-1).

Turning the crank handle raises or lowers the tray to increase or decrease the grilling heat.

WARNING: Exercise caution when adding charcoal or cranking the charcoal pan up/down. Use long-handled insulated BBQ tools and wear an insulated glove / oven mitt.

CHARCOAL SHIELD

The charcoal shield allows meat drippings to drip down to the drip tray without affecting the charcoal.

Place it over the coals (and beneath the cooking grids) as shown in Fig. 15-2.

The shield may also be used for smoking or indirect cooking methods. Simply set up as shown (using wood chips if desired), toward one side of the grill. Place the food on the opposite side of the grill.

CAUTION: DO NOT raise the charcoal pan so much that the charcoal shield comes in contact with the cooking grids.

AIR SHUTTERS

CAUTION: The air shutters become very hot when the grill is in use. Use a tool or heat-insulated glove to adjust the air shutters.

The air shutters (Fig. 15-3) on both sides of the smoker oven can be used to regulate the flow of air to the coals when the oven is closed.



Fig. 15-1 Charcoal pan

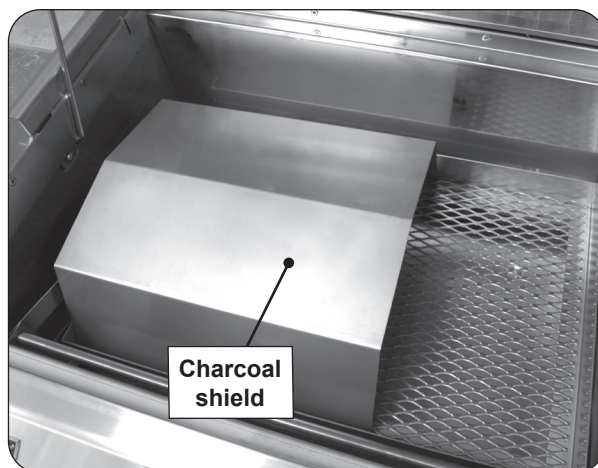

Fig. 15-2 Charcoal shield

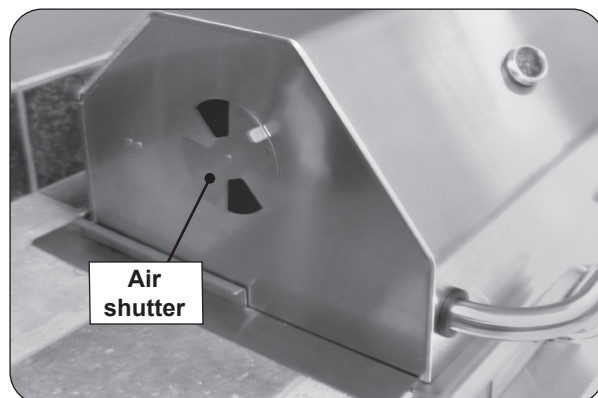

Fig. 15-3 Smoker hood air shutters

SERVICING AND CLEANING

Your grill requires regular cleaning and maintenance. Refer to these instructions for details. Performing these procedures will ensure proper operation, appearance, and safety.

WARNINGS

- Prior to servicing or cleaning make sure the unit is completely cool.
- Wear appropriate gloves and safety glasses during any servicing or cleaning.
- DO NOT spray any cleaner or liquids on the grill when hot.
- The grill **MUST** be cleaned regularly to prevent grease build-up and other food deposits. A clean and well maintained grill prevents the risk of grease build-up and grease fires.
- Verify proper operation after servicing or deep cleaning.
- See INSTALLATION, OPERATION, AND SAFETY INFORMATION section for additional related information.

CLEANING YOUR GRILL

Before Each Use

1. **Inspect and clean the exterior surfaces of the unit:** With a cool grill, clean any dust, grease, splatter, or spills as needed with a damp clean cloth.

After Each Use

1. **Perform a burn-off and clean the cooking grids:** Operate the grill hot with the hood closed for 15 minutes to burn-off food and grease and allow for an easier cooking grid clean. Then extinguish the hot charcoal and use a grill or scraper brush to clean the cooking grids of all residue. Use long-handled insulated BBQ tools and wear an insulated glove / oven mitt.
2. **Check and clean the charcoal components:** When the grill is cool, brush all the ash from the charcoal pan screen down to the drip tray. Pull out the drip tray, carefully lifting slowly with both hands to keep the tray level. Dispose of all ashes appropriately into a fireproof container.

Note: The drip tray has a heatshield to protect from overheating. It may be necessary to remove the heatshield to properly clean out the drip tray. When reinstalling, the heatshield dimples must face downward as shown in Fig. 16-1.

Clean the drip tray, drip tray heatshield, charcoal pan, and charcoal pan screen with a soapy water solution if needed. For tough deposits, a copper pad can be used. Rinse and dry completely. Replace the drip tray with heatshield, and charcoal pan with screen back to the grill.

3. **Cover your grill:** Once the grill is dry and cool, cover your grill with a Fire Magic protective cover (not included).

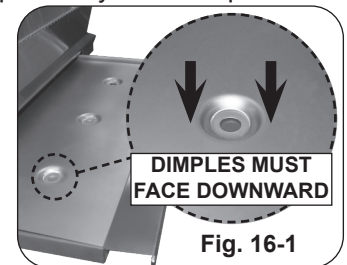

Twice A Year (or as needed) - Deep Clean

1. **Interior of grill:** In addition to cleaning the cooking grids and charcoal components, a deep clean of the grill interior, and all components **MUST** be performed twice year (or as needed depending on use). Refer to the CARE, CLEANING, & MAINTENANCE GUIDE provided with your grill, or simply scan the QR code on the right.
2. **Exterior of grill:** With a cool grill, use a grill cleaner (or a soapy water solution) and a clean cloth to remove grease and dirt from the outside of the grill. For tough deposits, a copper pad can be used. Always wipe with the grain. See Fig. 16-2. Rinse and dry completely. Then follow up with a stainless steel cleaner and a clean cloth.

If this routine cleaning is not performed, the stainless steel may become dull and develop surface rust (due to use and atmospheric conditions). If left uncleaned, significant damage and pitting may occur.

Important: DO NOT use steel wool, any other metal tools, or any other cleaners/chemicals to clean the exterior other than recommended above. Such items promote rust.

Note: Due to the nature of stainless steel, temperatures produced by the grilling process will cause discoloration. This can be reduced by routine cleaning.



Fig. 16-2 Wipe with grain

SERVICING AND CLEANING (cont.)

For Environments High In Salt, Chloride, Or Other Corrosive Chemicals

When this grill is installed in a corrosive environment such as near the ocean (salt air), poolside (chlorine and/or pool chemicals) or any other location with exposure to high salt/chloride content or corrosive chemicals/solutions, it will be more susceptible to corrosion and **MUST** be maintained/cleaned **more frequently**.

- **DO NOT** store any corrosive chemicals (chlorine, hydrochloric acid, fertilizer, etc.) near your stainless steel grill.
- **DO NOT** allow any corrosive materials (masonry dust, debris, etc.) to settle on your stainless steel grill.
- These environments, chemicals, and materials may cause the 304 stainless steel to develop surface rust and consequently pitting. Under these conditions the grill exterior **MUST** be cleaned at least monthly. Inspect your grill often and clean accordingly.

Protecting Your Grill

An optional protective cover will protect your grill when not in use. Install the cover on a cool and dry grill. **DO NOT** cover a damp grill. During high humidity or after rainy conditions, remove the cover to dry trapped moisture if present. (If the cover is installed over a damp grill it can cause surface rust.)

Ensure that the **INSIDE** of the cover is DRY before putting it back on the grill.

FACE REMOVAL

CAUTION: Ensure the grill is completely cool before beginning face removal.

1. Remove the drip tray.
2. Using a Phillips screwdriver, unscrew and remove the face screws and washers (located on the left and right front of the face). Retain the screws for later re-installation.
3. Remove the crank.
4. Carefully remove the face by lifting and pulling it from the frame.

Note: Be careful when removing the face as the access door may swing open in the process.

TROUBLESHOOTING

If you have trouble with the unit, please use this list to identify the problem. By trying one or more of the solutions to the possible cause, you should be able to solve the problem. If this list does not cover your present problem, or if you have other technical difficulties with the unit, please contact your local dealer.

PROBLEM	POSSIBLE CAUSE	CORRECTION
Charcoal grill is not getting hot	1. Dirty grill	1. Remove ashes from previous grilling. Ashes can trap moisture, causing difficulty to light charcoal.
	2. Damp charcoal	2. Ensure your charcoal is dry when lighting.
	3. Low quality charcoal	3. Use quality brand charcoal. Low quality brands can struggle reaching temperature and remaining lit.
	4. Old or used charcoal	4. Use new charcoal. Old or used charcoal can result in the grill not reaching temperature and can burn out quicker giving inconsistent heat.
	5. Charcoal went out	5. Carefully re-light your charcoal by following the instructions supplied with your charcoal. Ensure your charcoal is properly lit before spreading to distribute heat.
	6. Air shutters closed	6. Ensure the air shutters are fully open to provide maximum oxygen flow when lighting.
	7. Charcoal pan height is too low	7. Adjust the crank to raise the charcoal pan closer to the cooking grids.

WARRANTY

PETERSON FIRE MAGIC GRILLS AND ACCESSORIES LIMITED WARRANTY

R.H. Peterson Co. ("RHP") warrants your Fire Magic® grill to be free from defects in material and workmanship.

Fire Magic cast stainless-steel gas burners, Choice stainless steel U shaped burners, cooking grids, and Barbecue and vent hood housings are warranted **as long as the original purchaser owns them -- LIFETIME**. (Except as described below.)

Fire Magic brass valves, manifold assemblies, inner liners, porcelain housings (including ovens and barbecue faces), and **backburner assemblies** (except ignition systems) are warranted for **FIFTEEN (15) YEARS**.

Fire Magic built-in pizza ovens and griddles (except ignition system and thermostat) are warranted for **TEN (10) YEARS**.

Fire Magic heating elements, Infra-red burners, flavor grids, and charcoal stainless steel grills are warranted for **FIVE (5) YEARS**; except for the charcoal pan, charcoal grid, thermometer, and ash catch tray, which are warranted for **ONE (1) YEAR**.

Fire Magic sideburners, exterior Glass Fiber Reinforced Concrete (GFRC) grill island systems, and all other grill, vent hood, pizza oven and griddle components (except ignition systems and electronic parts) are warranted for **THREE (3) YEARS**.

Fire Magic Echelon gas grill, pizza oven and EL500 electric grill under glass touch screen electronic controls are warranted for **TWO (2) YEARS**.

Fire Magic grill, pizza oven and griddle ignition systems (excluding batteries), electronic components (including lights, thermometers and thermostats) and accessories are warranted for **ONE (1) YEAR**.

A COPY OF YOUR SALES SLIP FOR PROOF OF PURCHASE IS REQUIRED

This warranty applies to the original purchaser for products which are installed in the United States or Canada and which are operated and maintained as intended for single family residential usage. This warranty is valid only with proof of purchase, commences on the date of purchase, and terminates (both as to original and any replacement products) on the anniversary date of the original purchase of the product per the above schedules.

This warranty **does not** cover parts which become defective as a result of negligence, misuse, use not in compliance with the Installation and Owner's Manual, accidental damage, improper handling, improper storage, improper installation, **lack of required routine maintenance** (as specified in the Installation and Owner's Manual), electrical damage, local gas impurities or failure to protect against combustible materials. Product must be installed (and gas must be connected) as specified in the Installation and Owner's Manual by a **qualified professional installer**. This warranty **does not** apply to rust, corrosion, oxidation, or discoloration unless the affected part becomes inoperable. RHP products including valves, pilots and controls are designed and certified to be used as a system. Modifications to products which are not specifically authorized will void this warranty and could render the product to be unsafe. Burners, valves, parts, remotes, accessories, etc. used with this product must be RHP products or this warranty is void.

Warranted items will be repaired or replaced at RHP's sole discretion. This warranty **does not** cover labor or labor related charges, except as provided by separate specific written programs from RHP. All repair work must be performed by a qualified professional service person and requires prior approval of RHP.

RHP may require the defective product or part to be returned to the factory to determine the cause of failure. RHP will pay freight charges if the product or part is determined to be defective. This warranty does not cover breakage in shipment from our independent distributor to its customer if the damage is determined to have occurred during that shipment.

This warranty specifically excludes liability for **indirect, incidental, or consequential** damages. Some states and provinces do not allow the exclusion or limitation of incidental or consequential damages, so the above exclusion may not apply to you. This warranty gives you specified legal rights, and you may have other rights that vary from state to state or province.

For additional information regarding this warranty, or to place a warranty claim, contact the RHP dealer where the product was purchased.

When contacting your RHP dealer or the R.H. Peterson Co., please provide the following information:

- Your name, address, telephone number, e-mail
- Sales receipt showing where purchased and date purchased
- Model number, serial number of product, date code
- Relevant information: installer, additions, repairs, when defect was first noted

**TO REGISTER YOUR PRODUCT ONLINE GO TO: WWW.RHPETERSON.COM,
AND CLICK ON PRODUCT REGISTRATION. THANK YOU FOR YOUR PURCHASE.**

Quality Check	Date: _____	Model #: Serial #:
Workmanship Inspection: _____		
Inspector: _____		