

Models:
DVP Venting System



These venting system components have been tested for use with approved HHT Direct Vent appliances. Check with your local building code agency before you begin installation to ensure compliance with local codes, including the need for permits and follow-up inspections. If you encounter any problems regarding code approvals, or if you need clarification of any of the instructions contained here, contact your Hearth & Home Technologies dealer. For the dealer nearest you, please visit www.hearthnhome.com.

CAUTION! Risk of Cuts/Abrasions. Wear protective gloves and safety glasses during installation. Sheet metal edges are sharp.

A. Pipe Clearances to Combustibles

WARNING! Risk of Fire! Maintain air space clearance to vent. **DO NOT** pack insulation or other combustibles:

- Between ceiling firestops
- Between wall shield firestops
- Around vent system

Failure to keep insulation or other material away from vent pipe may cause over heating and fire.

Refer to appliance installation manuals for clearances.

B. Wall Penetration Framing

- Wherever a combustible wall is penetrated, the hole must be framed and a wall shield installed. When a wall is penetrated the wall shield is only required on one side and no heat shield is necessary. If your local inspector requires a wall shield on both sides, then both wall shields must have a heat shield attached to them. These shields maintain minimum clearances and restrict cold air infiltration.
- If the wall being penetrated is of noncombustible materials (material which will not ignite or burn, or has a UL fire rating of zero), a hole 1 in. (25 mm) larger in diameter than the pipe is acceptable.

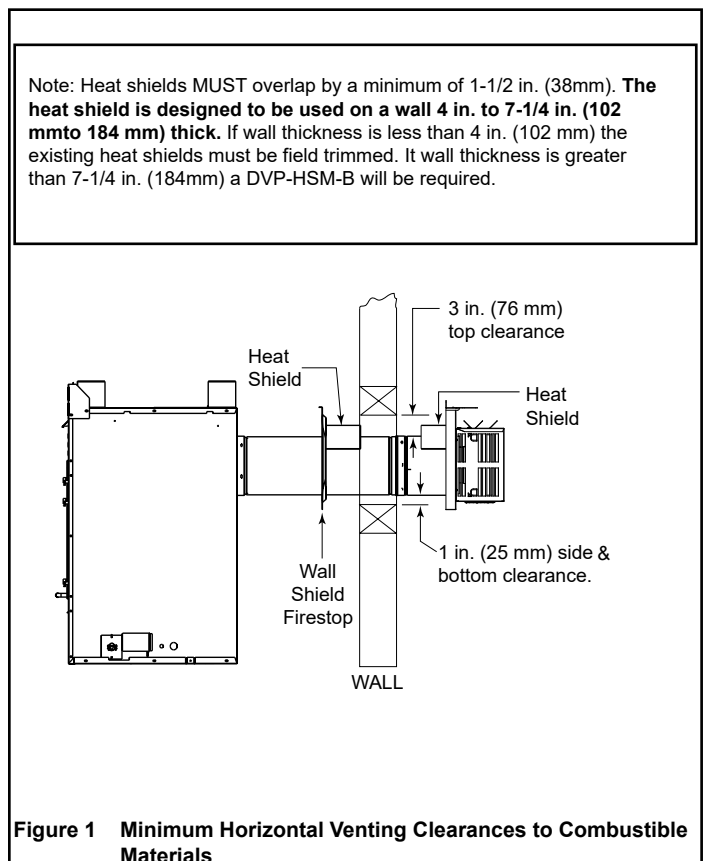

C. Install the Ceiling Firestop

- Frame an opening 10 in. x 10 in. (254 mm x 254 mm) whenever the vent system penetrates a ceiling/floor (see Figure 2)
- Frame the area with the same sized lumber as used in ceiling/floor joist.
- When installing a top vent vertical termination appliance the hole should be directly above the appliance, unless the flue is offset.
- The ceiling firestop may be installed above or below the ceiling. Refer to Figure 3.
- Secure with three fasteners on each side.
- Do not pack insulation around the pipe. Insulation must be kept away from the pipe.

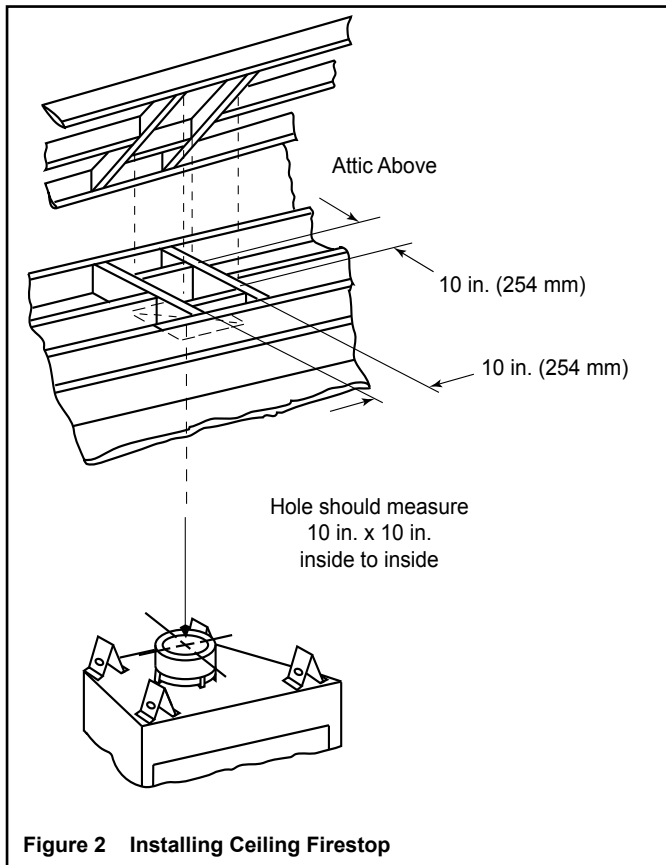

Figure 2 Installing Ceiling Firestop

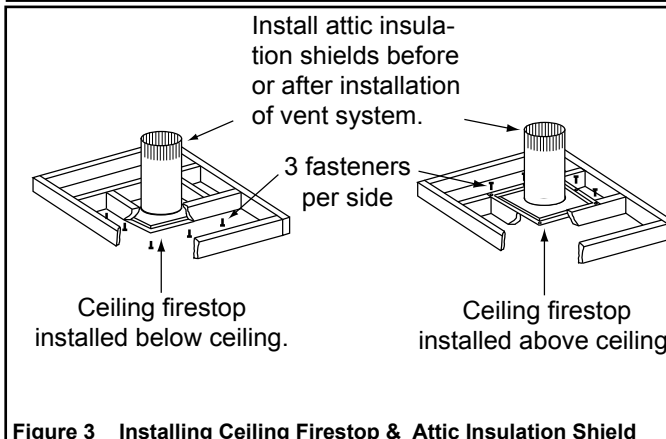

Figure 3 Installing Ceiling Firestop & Attic Insulation Shield

D. Install Attic Insulation Shield

WARNING! Fire Risk. DO NOT allow loose materials or insulation to touch vent. *Hearth & Home Technologies requires the use of an attic shield.*

The National Fuel Gas Code ANSI Z223.1 requires an attic shield constructed of 26 gauge minimum metal that extends at least 2 in. (51 mm) above insulation.

Attic shields must meet specified clearance and be secured in place.

Flat Ceiling Installation

- Remove one shield from box.
Note: Cut previously installed batt insulation to make room for the attic insulation shield.
- Wrap shield around pipe if pipe is already installed in area to be insulated.
- Match the three holes in each side and fasten with three screws to form a tube.
- One or more tabs may be folded outward on the bottom of the shield to allow attachment to ceiling firestop.
- Bend remaining tabs inward on bottom of shield where it rests on the ceiling firestop to maintain the air space between the pipe and shield. Set the shield on the ceiling firestop.
- Bend all tabs inward 90° around the top of the shield. These tabs must be used to prevent blow-in insulation from getting between the shield and vent pipe, and to maintain clearance.

Vaulted Ceiling Installation

- The attic insulation shield has been laser-etched with cut lines and ceiling pitches to make field trimming easier.
- Remove one shield from box.
Note: Cut previously installed batt insulation to make room for the attic insulation shield.
- Cut the attic insulation shield (if application is for vaulted ceiling) using a laser-etched cut line, to fit your ceiling pitch. Snip cut edge to create three bend tabs.
- Wrap shield around pipe if pipe is already installed in area to be insulated.
- Match the three holes in each side and fasten with three screws to form a tube.
- One or more tabs may be folded outward on the bottom of the shield to allow attachment to ceiling firestop.
- Bend remaining tabs inward on bottom of shield where it rests on the ceiling firestop to maintain the air space between the pipe and shield. Set the shield on the ceiling firestop.
- Bend all tabs inward 90° around the top of the shield. These tabs must be used to prevent blow-in insulation from getting between the shield and vent pipe, and to maintain clearance.

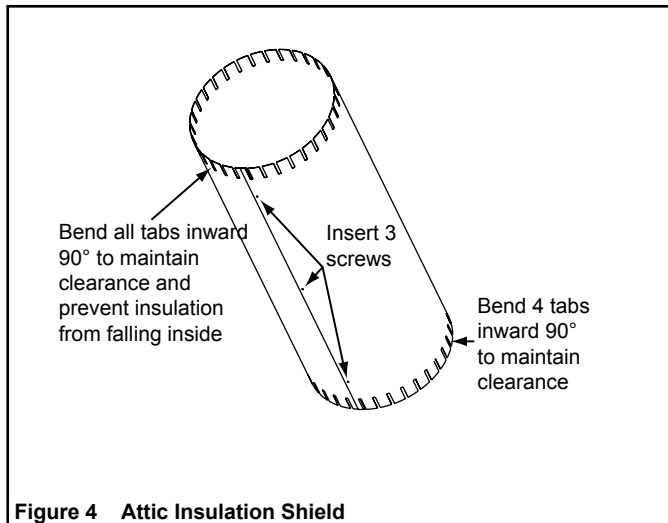

Figure 4 Attic Insulation Shield

E. Assemble DVP Vent Sections

WARNING! Risk of Fire/Explosion/Asphyxiation! Improper support may allow vent to sag and separate. Use vent run supports and connect vent sections per installation instructions. **DO NOT** allow vent to sag below connection point to appliance.

Attach the First Vent Component to Starter Collar

To attach the first vent component to the starting collar of the appliance:

- Slide the male end of the inner flue over the inner collar of the appliance, at the same time, slide the outer flue over the outer collar of the appliance.
- Push the pipe section into the appliance collar until all the lances have snapped in place.
- Tug slightly on the section to confirm it has completely locked into place.

Note: The end of the pipe sections with the lances/tabs on it will face toward the appliance.

Commercial, Multi-family (multi-level exceeding two stories), or High-rise Applications

For installation into a commercial, multi-family (multi-level exceeding two stories), or high-rise application: All outer pipe joints must be sealed with high temperature silicone, including the slip section that connects directly to the horizontal termination cap.

- Apply a bead of silicone sealant inside the female outer pipe joint prior to joining sections. See Figure 5.
- Only outer pipes are to be sealed. Do not seal the inner flue. All unit collar, pipe, slip section, elbow and cap outer flues shall be sealed in this manner, unless otherwise stated.

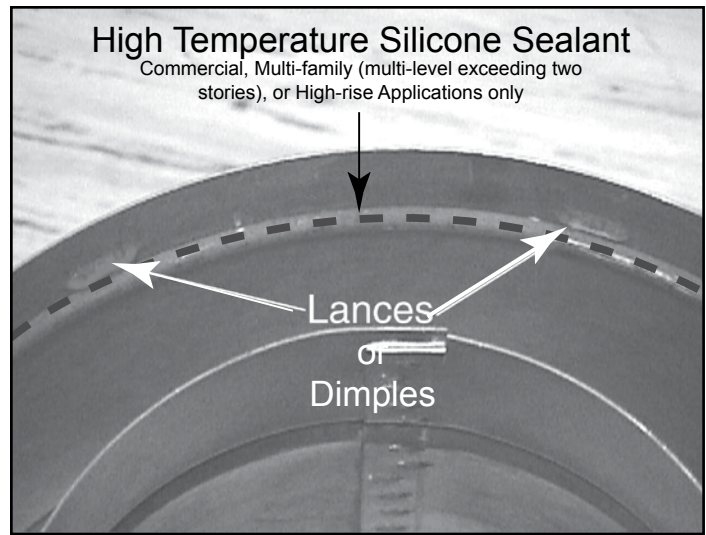

Figure 5 High Temperature Sealant

Assemble Pipe Sections

Insert the inner flue of section A into the flared inner flue of section B. (See figure 6).

Start the outer flue of section A over the outer flue of section B.

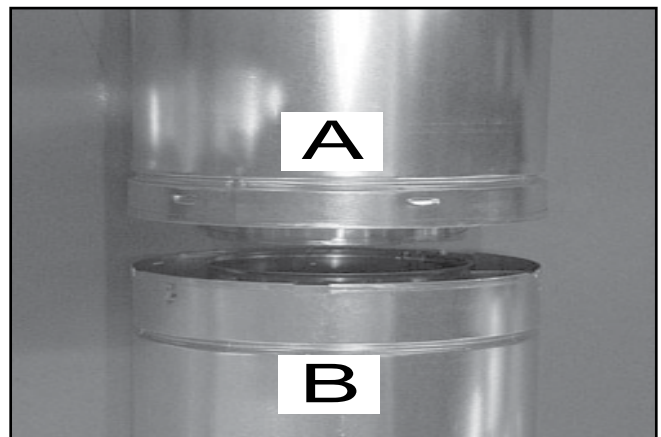

Figure 6 Inner/Outer

Once both inner and outer flues are started, press section A onto section B firmly until all lances have snapped into place. Check to make sure they have snapped together (see Figure 7) and the seams are not aligned (see Figure 8). Tug slightly on section A to confirm it has completely locked into place.

- It is acceptable to use screws no longer than 1/2 in. to hold outer pipes together. If predrilling screw holes do NOT penetrate inner pipe.

For 90° and 45° elbows that are changing the vent direction from horizontal to vertical, one screw minimum should be put in the outer flue at the horizontal elbow joint to prevent the elbow from rotating. Use screws no longer than 1 in. If predrilling screw holes do NOT penetrate inner pipe.

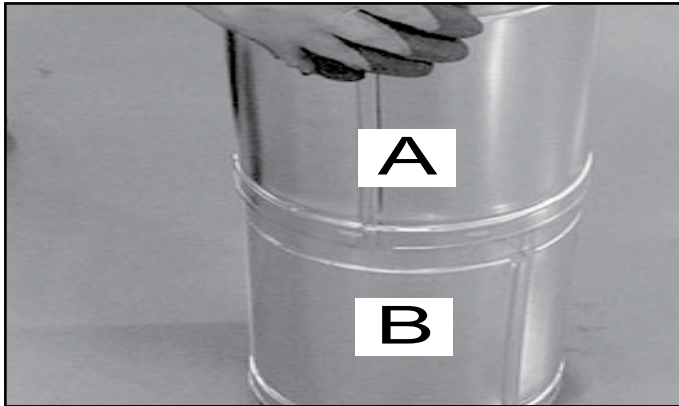
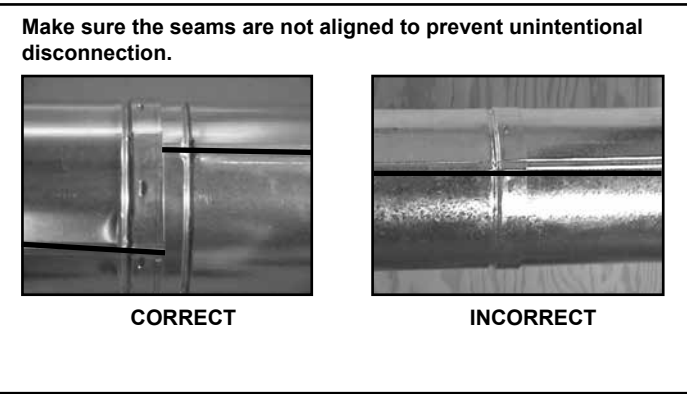

Figure 7 Snapped



WARNING! Risk of Fire/Explosion! DO NOT break silicone seals on slip sections. Use care when removing termination cap from slip pipe. If slip section seals are broken during removal of the termination cap, vent may leak.

⚠ WARNING

Fire Risk

Exhaust Fumes Risk

- Overlap pipe slip sections at least 1-1/2 inches.
- Use pilot holes for screws.
- Screws must not exceed 1/2 in. long.
- Pipe may separate if not properly joined.

Assemble Slip Sections

The outer flue of the slip section should slide over the outer flue of the pipe section and into (inner flue) the last pipe section (see Figure 10) .

Slide together to the desired length, making sure that a 1-1/2 in. outer flue overlap is maintained between the pipe section and slip section.

The pipe and slip section need to be secured by driving two screws through the overlapping portions of the outer flues using the pilot holes (see Figure 11).

This will secure the slip section to the desired length and prevent it from separating. The slip section can then be attached to the next pipe section.

If the slip section is too long, the inner and outer flues of the slip section can be cut to the desired length.

Note: When installing a vent system with an HRC termination cap, all pipe system joints shall be sealed using a high-temperature silicone sealant.

- Apply a bead of silicone sealant inside the female outer pipe joint prior to joining sections.
 - Only outer pipes are sealed, sealing the inner flue is not required. All unit collar, pipe, slip section, elbow and cap outer flues shall be sealed in this manner.
- Check appliance installation instructions for approval with HRC Series cap.

Figure 9 MI Sections

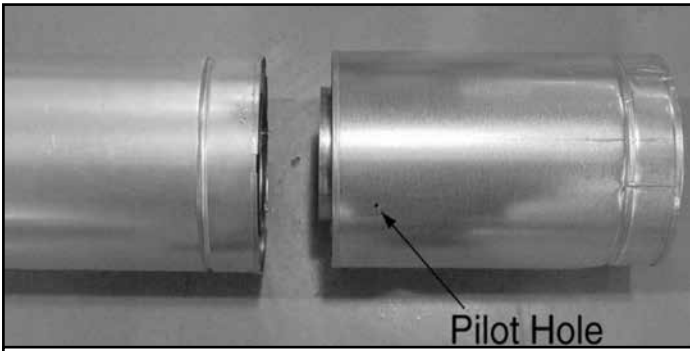

Figure 10 Slip Section Pilot Holes

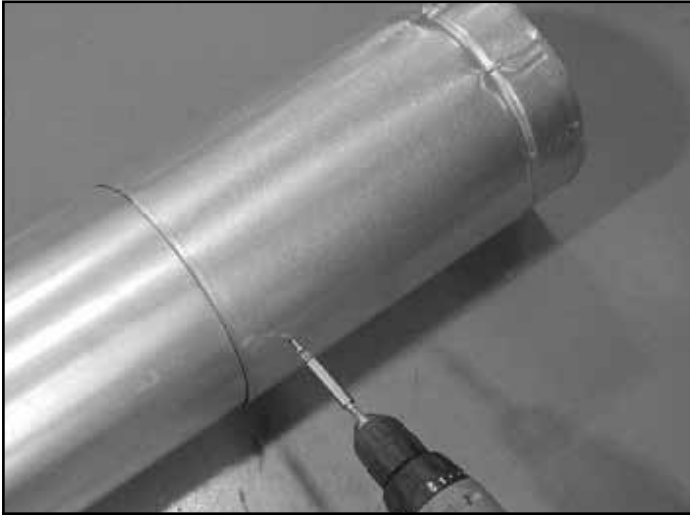

Figure 11 Screws into Slip Section

Secure the Vent Sections

Vertical sections of pipe must be supported every 8 ft. after the 25 ft. maximum unsupported rise. The vent support or plumber's strap (spaced 120° apart) may be used to do this (see Figure 12).

Horizontal sections of vent must be supported every 5 ft with a vent support or plumber's strap. (See Figure 13)

WARNING! Risk of Fire/Explosion/Asphyxiation! Improper support may allow vent to sag and separate. Use vent run supports and connect vent sections per installation instructions. **DO NOT** allow vent to sag below connection point to appliance.

F. Disassemble Vent Sections

To disassemble any two pieces of pipe, rotate either section (Figure 14), so that the seams on both pipe sections are aligned (Figure 15). They can then be carefully pulled apart.

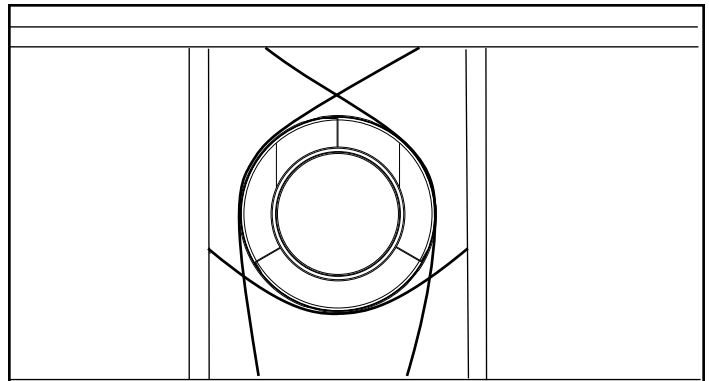

Figure 12 Securing Vertical Pipe Sections

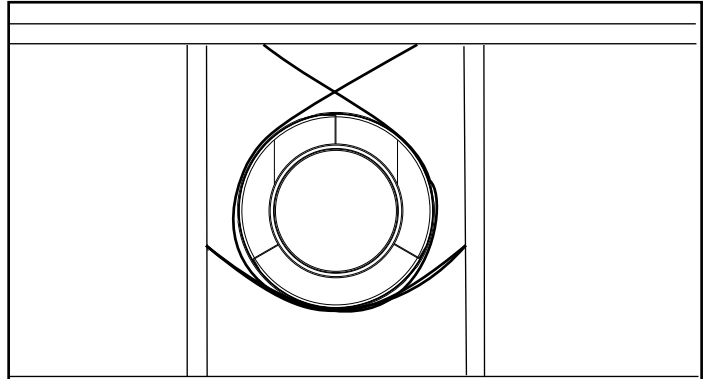

Figure 13 Securing Horizontal Pipe Sections

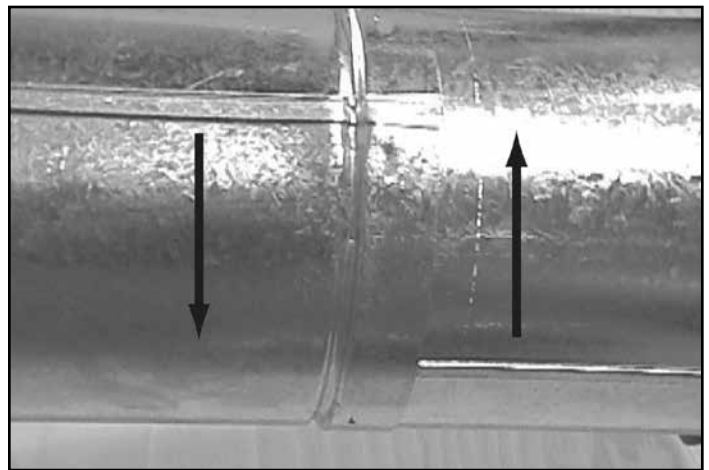

Figure 14 Rotate Seams for Disassembly

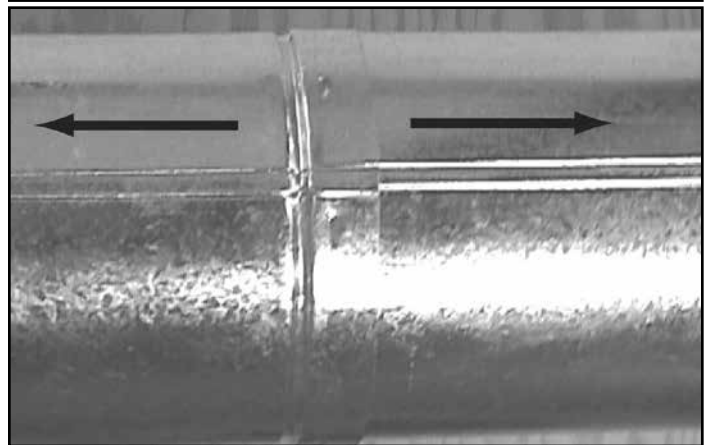

Figure 15 Align and Disassemble Vent Sections

G. Install the Heat Shield and Horizontal Termination Cap

WARNING! Risk of Fire! The telescoping flue section of the termination cap **MUST** be used when connecting vent.

- 1-1/2 (38 mm) minimum overlap of vent and telescoping flue section is required.

Failure to maintain overlap may cause overheating and fire.

Note: For horizontal vent runs through a combustible wall and framing dimensions, refer to appliance installation manual.

Heat Shield Requirements for Horizontal Termination

For all horizontally terminated appliances, a heat shield **MUST** be placed 1 in. above the top of the vent between the wall shield firestop and the base of the termination cap.

There are two sections of the heat shield. One section is factory-attached to the wall shield firestop. The other section is factory-attached to the cap.

WARNING! Risk of Fire! TO PREVENT overheating and fire, heat shields must extend through the entire wall thickness. Heat shields must overlap 1-1/2 in. (38 mm) minimum.

If the wall thickness does not allow the required 1-1/2 in. (38 mm) heat shield overlap when installed, an extended heat shield must be used.

If the wall thickness is less than 4-3/8 in./111 mm, the heat shields on the cap and wall shield firestop will need to be trimmed. A minimum 1-1/2 overlap **MUST** be maintained.

NOTICE: Heat shields may not be field constructed.

The extended heat shield may need to be cut to length. You will attach the cut heat shield to the existing cap heat shield or wall shield firestop heat shield using the supplied screws.

You **MUST** maintain a 1-1/2 in. (38 mm) overlap of the extended heat shield and the existing shields (both ends of the heat shield). The small leg on the extended heat shield should rest on the top of the vent (pipe section) to properly space it from the pipe section.

Install the Horizontal Termination Cap

Attach slip section of cap to last vent section. Maintain 1-1/2 in. overlap between slip and vent sections.

Secure termination cap to exterior wall using provided holes and fasteners.

Vent termination must not be recessed in the wall. Siding may be brought to the edge of the cap base.

Flash and seal as appropriate for siding material at outside edges of cap.

When installing a horizontal termination cap, follow the cap location guidelines as prescribed by current **ANSI Z223.1** and **CAN/CGA-B149** installation codes.

Note: When using termination caps with a factory-supplied heat shield attached, no additional wall shield firestop is required on the exterior side of a combustible wall.

CAUTION! Risk of Burns! Local codes may require installation of a cap shield to prevent anything or anyone from touching the hot cap.

Note: Where required, an exterior wall flashing is available. When penetrating a brick wall, a brick extension kit is available for framing the brick.

H. Divert Roof Run-off

HHT recommends, where excessive water run-off is possible, use of one of the two options shown below to prevent water running off the roof and onto/into the horizontal termination cap:

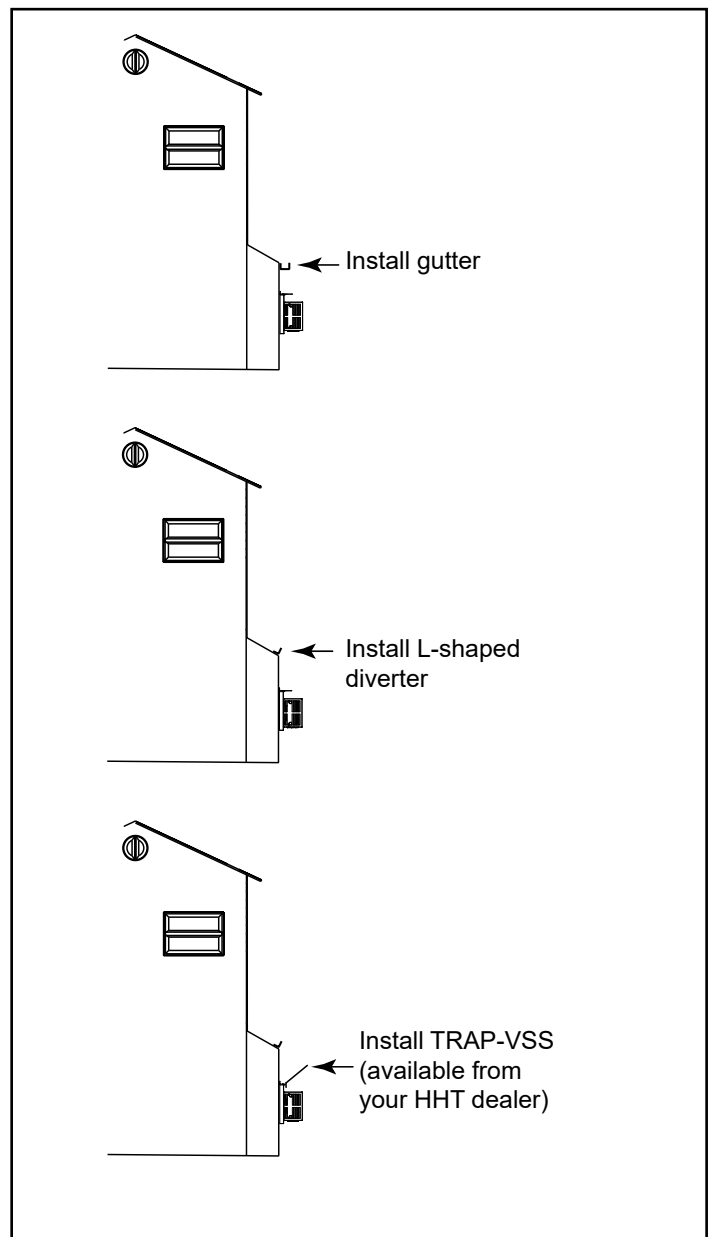
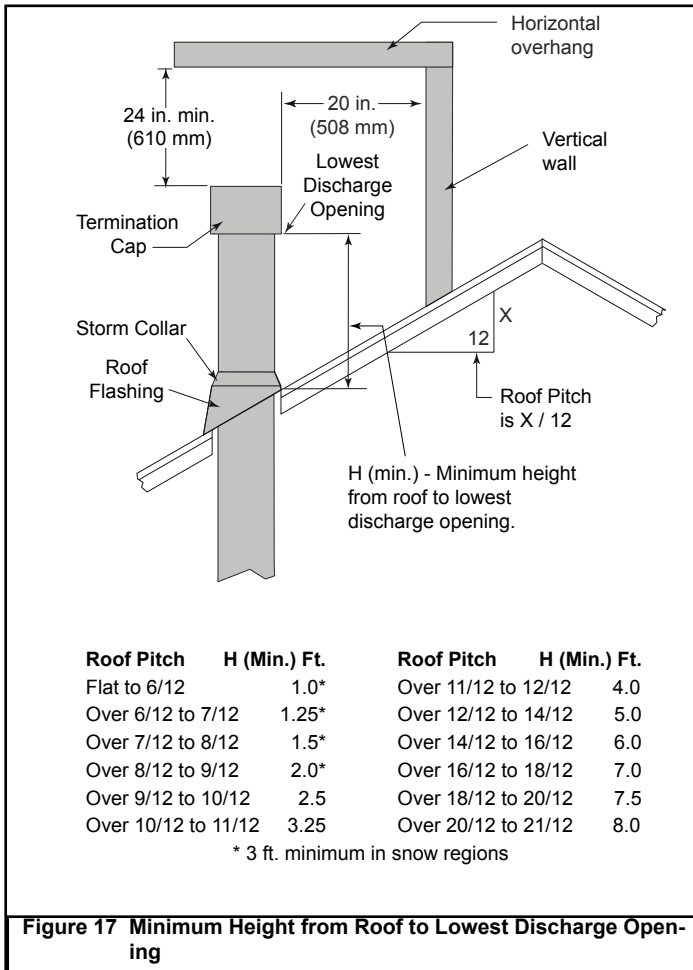

Figure 16 Divert Roof Run-off

I. Install Roof Flashing

To install roof flashing see Figures 18 and 19. For installation of vertical termination cap see minimum vent heights for various pitched roofs (see Figure 17) .



Using a 300° F minimum noncombustible caulk, caulk the gap between the roof flashing and the outside diameter of the pipe. Caulk all seams and (see figure 18) the perimeter of the flashing where it contacts the roof surface.

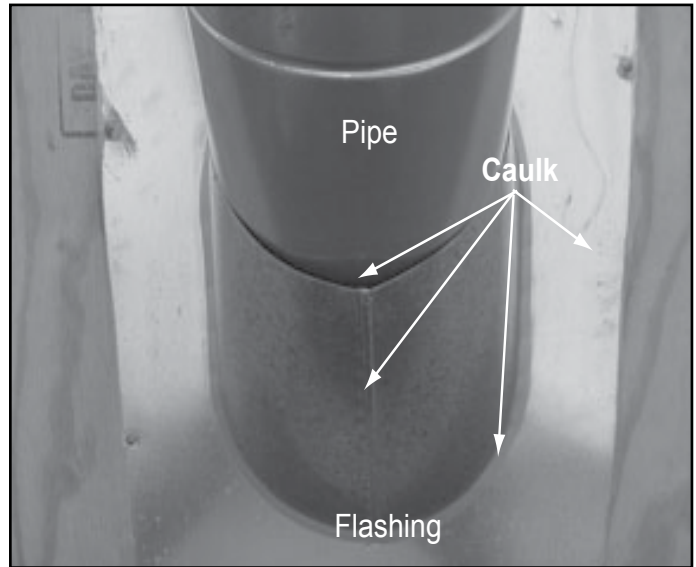

Figure 18 Caulk the Cap

J. Assemble and Install Storm Collar

- Slide the storm collar onto the exposed pipe section and align brackets.
- Insert a bolt (provided) through the brackets and install nut (do not completely tighten).



Figure 19 Insert Bolt into Brackets

- Slide the assembled storm collar down the pipe section until it rests on the roof flashing.
- Tighten nut and make sure the collar is tight against the pipe section.
- ▶ • Caulking - See Figure 20
 1. Around the top of the storm collar, where the collar contacts the vertical vent pipe.
 2. The seam where the two halves of the storm collar meet.
 3. The vertical seam of the vent pipe.

K. Install Vertical Termination Cap

To attach the vertical termination cap, slide the inner collar of the cap into the inner flue of the vent section and place the outer collar of the cap over the outer flue of the vent section.

Secure the cap by driving the three self-tapping screws (supplied) through the pilot holes or dimples in the outer collar of the cap into the outer flue of the vent.



► **Figure 20 Secure with Screws**