

**AUTOMATIC REMOTE LIGHTING SAFETY PILOT SYSTEM
FOR NATURAL OR PROPANE GAS
& FOR USE WITH PETERSON GAS LOG SETS ONLY**

FEATURES

- SWITCH OPERATED ON/OFF •
- OPTIONAL REMOTE READY •

SUITABLE FOR THE FOLLOWING BURNERS:

- PAN BURNERS (P-SERIES) •
- G4 SERIES BURNERS •
- G45 SERIES BURNERS •

90,000 BTU CAPACITY

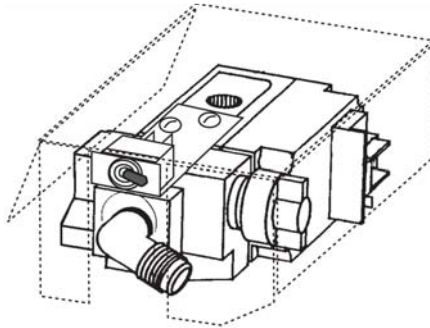

Installer: Leave this manual with the consumer.

Consumer: Retain this manual for future reference.

Model APK-11(M)(P)

FOR USE WITH PETERSON GAS LOG SETS ONLY

WARNING

If the information in this manual is not followed exactly, a fire or explosion may result, causing property damage, personal injury, or loss of life.

- Do not store or use gasoline or other flammable vapors and liquids in the vicinity of this or any other appliance.

WHAT TO DO IF YOU SMELL GAS:

- Open a window.
- Do not try to light any appliance.
- Do not touch any electrical switch; do not use any phone in the building.
- Immediately call the gas supplier from a neighbor's phone. Follow the gas supplier's instructions.
- If you cannot reach the gas supplier, call the fire department.

- **Installation and service must be performed by a qualified installer, service agency, or the gas supplier.**

INSTALLER & CONSUMER

These instructions **MUST** be retained with this appliance

Important: Read these instructions carefully before starting installation.

**BE SURE DAMPER IS FULLY OPEN
WHEN OPERATING THE LOG SET**

PETERSON VENTED GAS LOG SETS ARE TO BE OPERATED ONLY IN A FULLY VENTED, NONCOMBUSTIBLE FIREPLACE WITH DAMPER AND CHIMNEY FREE OF ANY OBSTRUCTIONS. THE FIREPLACE MUST BE DESIGNED AND APPROVED TO BURN WOOD. Like burning natural firewood, the Peterson log set is designed to burn with a yellow, smoky flame. For this reason, it must be adequately vented. Be sure the fireplace damper is fully open when you burn the gas log set. The smallest dimension of the chimney flue must be at least 8". If it is smaller, DO NOT USE A PETERSON LOG SET. If fumes from the burner emerge into the room when the damper is fully open, creating a smell like a smoldering oil lamp, it indicates that the fireplace draft is defective. Check chimney flue for obstructions. DO NOT OPERATE LOGS UNTIL THE FIREPLACE DRAFT IS CORRECTED. Check with your dealer or installer. Do not use firewood with this unit. **This safety pilot system contains a control certified by C.S.A.**

TABLE OF CONTENTS

PARTS LIST	3
IMPORTANT INFORMATION	3
INSTALLATION INSTRUCTIONS	4
SAFETY VALVE INSTALLATION	4
MOUNTING THE PILOT ASSEMBLY TO THE PETERSON REAL-FYRE® BURNER	5
OPERATING INSTRUCTIONS	6
TROUBLESHOOTING	7
WARRANTY	8

IMPORTANT INFORMATION

The installation, including provisions for combustion and ventilation air, must conform with local codes or, in the absence of local codes, with the National Fuel Gas Code, ANSI Z223.1 (latest edition).

This appliance and its individual shutoff valve must be disconnected from the gas supply piping system when testing at pressures exceeding 1/2 psig. Do this by closing the gas supply valve.

This appliance must be isolated from the gas supply piping system by closing its individual manual shutoff valve during any testing of the gas supply system at test pressures up to and including 1/2 psig.

WHEN GLASS FIREPLACE ENCLOSURES (DOORS) ARE USED, OPERATE THE GAS LOG SET WITH THE GLASS DOORS FULLY OPEN; BOTH SIDES IF FIREPLACE IS SEE-THRU TYPE.

PARTS LIST

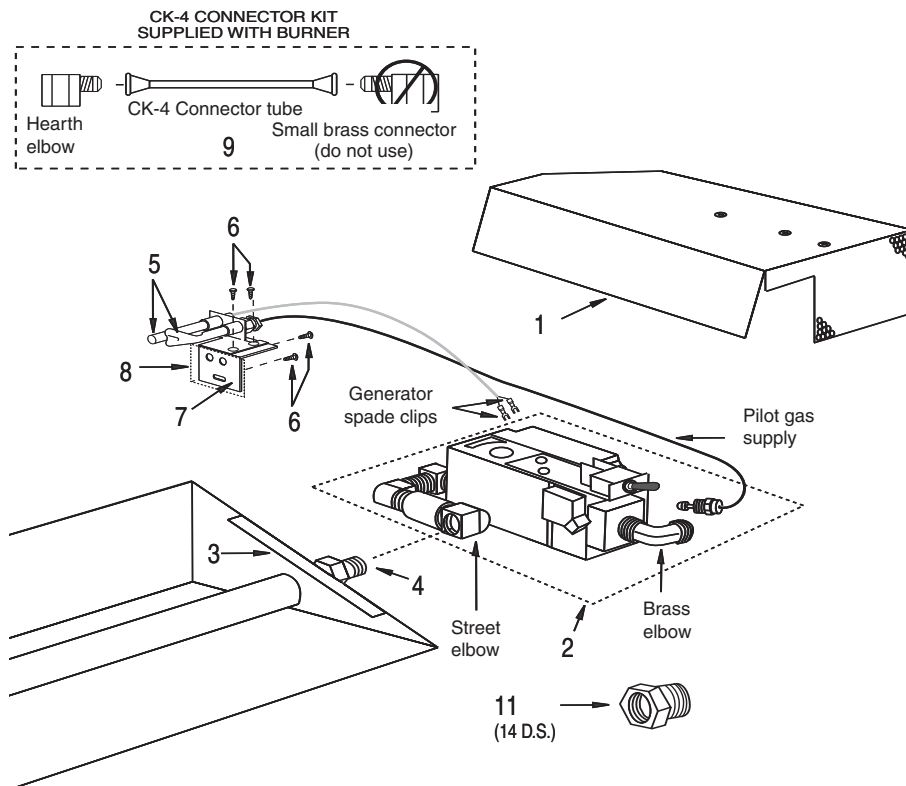

Item	Description	Item	Description
1.	Radiant heatshield	5.	Pilot assembly <ul style="list-style-type: none"> • Generator • Pilot gas supply
2.	Valve assembly <ul style="list-style-type: none"> • Safety valve • Brass elbow (flare) • 3/8" NPT close nipple • 3/8" coupling • Street elbow 3/8 (3 req.) • Toggle switch • Switch bracket 	6.	Screw #10 x 3/8 PH, BLK (4 req.)
3.	Flame diverter bracket	7.	Mounting bracket
4.	Fuel injector (for use with natural gas log sets only) Air mixer not shown (for use with propane gas log sets) Item 4 is supplied with burner assembly	8.	Burner insulation pad
		9.	Connector kit (supplied w/burner)
		10.	1/4" slotted bolt and nut (For front flame burner installation only. Not shown in illustration above.)
		11.	Fuel injector (enlarged for use with 24" - 30" natural gas log sets)
		12.	RR-1A remote kit (if equipped)

INSTALLATION INSTRUCTIONS

(Refer to the PARTS LIST when following these instructions.)

GENERAL

Be sure the automatic remote lighting safety pilot system has been assembled for the proper gas. Systems labeled APK-11(M) are for natural gas and APK-11(M)P are for propane gas. APK-11(M) is for use only with Peterson natural gas burner systems sizes 12" to 30". Larger burner systems should use the APK-10(M).

Note: APK-11(M)P can be used on all standard size propane burner systems to 30" and on see-thru propane burner systems up to 18".

A fuel injector (for natural gas) is included with the unit which contains an enlarged orifice (14 D.S.). If you are using a 24" or 30" natural gas log set, remove the fuel injector from the burner pan and replace it with the enlarged fuel injector. There is no need to replace the air mixer if using propane gas.

Note: If the flame height is adequate, there is no need to use the enlarged orifice (14 D.S.) provided with this kit. Be sure all cautions and warnings contained in the Peterson gas log instructions are followed.

These instructions must be used as a supplement to the instructions supplied with the gas log set. Follow the gas log set instructions and make adjustments as appropriate for the addition of the unit. Gas supply must be 1/2" minimum I.D. and with proper pressures. Use Teflon tape or pipe sealing compound that is resistant to propane gas on all male pipe connections. Make sure that all connections are tight.

Note: This unit adds six additional inches to the footprint of the burner system.

SAFETY VALVE INSTALLATION

Use Teflon tape or pipe compound for all male pipe connections to prevent gas leaks.

Note: The valve assembly is pre-assembled for ease of installation. The valve must be installed on the right side of the burner.

PLACEMENT OF THE APK SAFETY VALVE

Correct placement of the APK safety valve in the fireplace is important to ensure proper operation. The valve must be placed in the front right corner of the fireplace. Placement in the front left corner of the fireplace or outside the firebox is also permitted, but may require additional connecting parts.

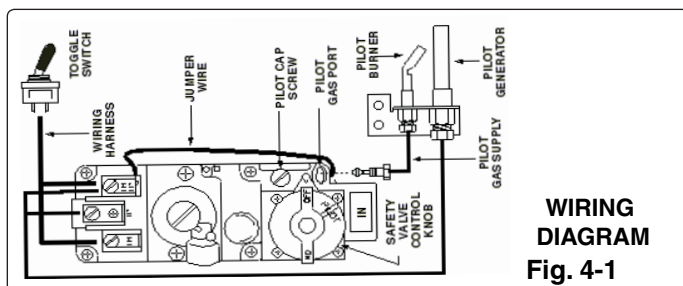

CONNECTING THE SAFETY VALVE TO THE BURNER

1. Follow the instructions supplied with the Peterson gas log set for proper burner placement.
2. Attach the street elbow (see PARTS LIST) to the fuel injector or air mixer (Item 4) supplied with burner. Ensure all connections are tight.

INSTALLATION ON SEE THRU BURNER

Connect the street elbow to the "tee" fitting on the burner manifold. Ensure all connection are tight.

Important: For safe and correct operation, attach pilot assembly to **the burner pan that receives gas first** during operation (see Fig. 3-1).

CONNECTING THE SAFETY VALVE TO THE GAS SUPPLY

1. Turn off the gas supply to the fireplace.
2. Attach the hearth elbow supplied with the CK-4 connector kit (Item 9) to the gas supply. This item is supplied with the burner assembly.
3. Remove and discard the small brass connector elbow from the CK-4. Attach the CK-4 connector tube, one end to the hearth elbow that is attached to the gas supply and the other end to the brass elbow that is attached to the safety valve.

CONNECTING THE PILOT ASSEMBLY TO THE SAFETY VALVE

1. Connect one of the spade clips on the wires from the generator (Item 5) to the terminal screw marked TP and the other spade clip to the terminal screw marked TH-TP on the safety pilot valve (Item 2). Tighten screws.

Note: Two wires, one from the toggle switch control and one from the generator, should be connected to terminal screw marked TH-TP. BE SURE THE JUMPER WIRE IS IN PLACE (Fig. 3-1).

2. Screw the pilot gas supply (Item 5) to the safety valve at the pilot gas port marked **PILOT**. Be sure the connection is tight.

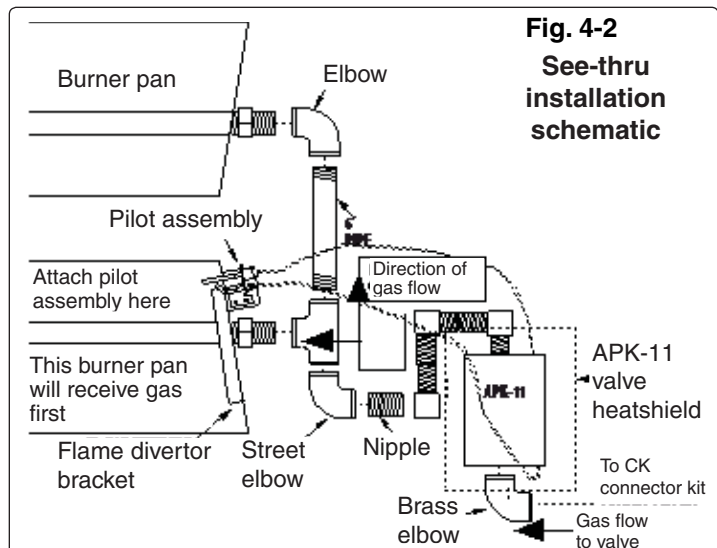

INSTALLATION INSTRUCTIONS (cont.)

(Refer to the PARTS LIST when following these instructions)

RADIANT HEATSHIELD PLACEMENT

Cover the safety valve (Item 2) with the radiant heatshield (Item 1). Be sure the solid black face of the shield is between the valve and the burner.

MOUNTING THE PILOT ASSEMBLY TO THE PETERSON REAL-FYRE® BURNER

1. ATTACHING THE FLAME DIVERTER BRACKET ON THE BURNER

Attach the flame diverter bracket (Item 3) to the side wall of the burner pan nearest to the valve. The flame diverter bracket should be placed approximately 1 1/4" from the back side of the burner pan.

Note: The flame diverter bracket is used only on G4, GX4, VG4, and P series burners.

2. GLOWING EMBER BURNER - G4, GX4, AND VG4 SERIES

- Attach the pilot assembly mounting bracket (Item 7) to the pilot assembly (Item 5) with #10 screws (Item 6) (Fig. 4-1).

Note: Bracket, insulation pad and pilot assembly are shown attached.

- Place the burner insulation pad (Item 8) between the bracket and the burner. Insert the screws (Item 6) through the pilot assembly, insulation pad, and holes in the side of the burner, and tighten.

3. PAN BURNER — P SERIES

- Attach the pilot assembly mounting bracket (Item 7) to the pilot assembly (Item 5) with #10 screws (Item 6), as shown in Fig. 4-2.

Note: Bracket, insulation pad, and pilot assembly are shown attached.

- Place the burner insulation pad (Item 8) between the bracket and the burner. Insert the screws (Item 6) through the pilot assembly, insulation pad, and holes in the side of the burner.

Note: The generator and gas supply leads should not be touching the burner pan or be placed in the fire.

CHECK ALL CONNECTIONS FOR GAS LEAKS USING A SOAPY WATER SOLUTION. NEVER USE AN OPEN FLAME TO CHECK FOR GAS LEAKS.

Hearth elbow
CK-4 Connector tube

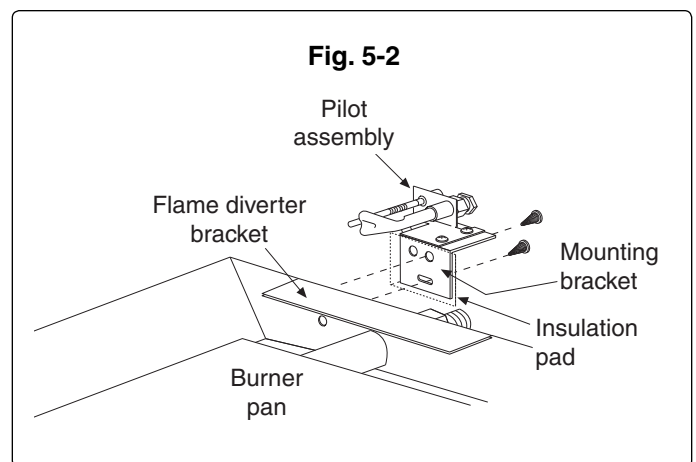
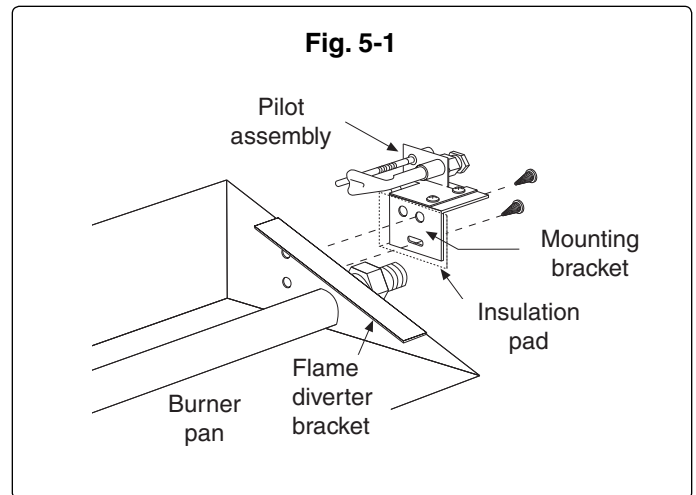

Note: The APK-11(M)(P) is compatible with all Peterson remote control options. Contact your Peterson dealer for more information.

OPERATING INSTRUCTIONS

HOW TO LIGHT THE PILOT

To light the pilot from the **PILOT** position, push in slightly on the safety valve knob and turn to the **OFF** position. Wait five minutes, then turn the safety valve knob to the **PILOT** position. Push the safety valve knob fully in and at the same time place a long match or a butane lighter at the pilot burner. The pilot will light. Hold the safety valve knob in for approximately 60 seconds. If the pilot does not stay lit, turn the safety valve knob to the full **OFF** position. Wait five minutes and repeat the LIGHTING INSTRUCTIONS.

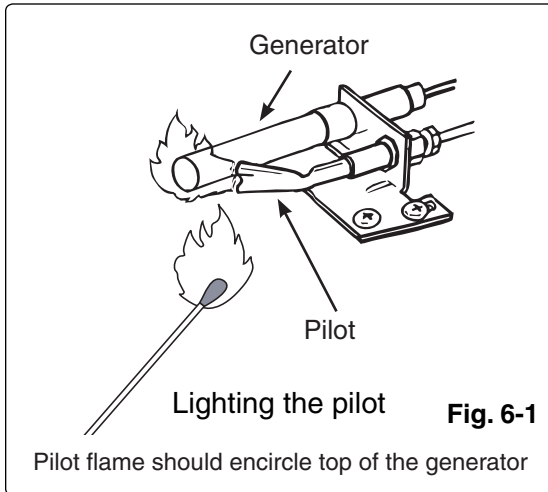

PILOT ADJUSTMENT

- A. The pilot flame should encircle the generator tip, which is preset at the factory (Fig. 2-1). Ordinarily, the pilot will not require field adjustment.
- B. If adjustment is necessary, remove the cap screw and turn the smaller gas adjustment screw inside counter-clockwise to increase the pilot flame and clockwise to decrease the pilot flame. Replace cap screw. Refer to Fig. 3-1, page 3.

HOW TO TURN THE GAS LOG SET ON AND OFF USING THE APK SYSTEM

To turn on the gas log set with the pilot lit, turn the safety valve knob to the **ON** position. Switch the toggle switch control to the **ON** (up) position and the gas log set will light.

To turn off the gas log set, switch the toggle switch control to the **OFF** (down) position. The pilot will remain lit.

To turn off the pilot, be sure the toggle switch control is **OFF**, and depress and turn the safety valve knob to the **OFF** position.

For remote lighting; follow the instructions for lighting the pilot above and then follow the instructions that came with your remote.

MAINTENANCE OF THE APK SYSTEM

The log set is equipped with a safety pilot that will shut off the gas supply in case the pilot is not burning or functioning properly. Make sure the pilot is adjusted properly and that the generator spade clips are tightly connected to the terminal screws on the valve. If the pilot will not stay lit, call the local gas utility or gas supplier.

A periodic check of the following should be performed at least annually by a qualified, professional service representative:

1. Valves and toggle switch control for proper operation.
2. Flue system for rust, damage, or leaks.
3. Damper operation.
4. Orifices for dirt or other foreign matter.
5. Visual check on the burner.

TROUBLESHOOTING

PROBLEM	CAUSE	SOLUTION
1. Pilot will not stay lit	<ul style="list-style-type: none"> a. Pilot generator may not be producing sufficient millivoltage b. Pilot flame is making a blowing noise c. Generator wire leads are attached to the wrong terminals on the valve d. Defective thermomagnet safety in the valve 	<ul style="list-style-type: none"> a. Check with a millivolt meter. Should be 250 millivolts or more b. Pilot needs adjusting. See PILOT ADJUSTMENT c. See CONNECTING PILOT ASSEMBLY TO SAFETY VALVE D. Replace valve
2. Pilot burning - no gas to burner	<ul style="list-style-type: none"> a. Safety valve not turned to the ON position after lighting pilot. b. Wire leads are not connected to the proper valve terminals or toggle switch terminals are not tight c. Pilot generator may not be producing sufficient millivoltage d. Defective valve 	<ul style="list-style-type: none"> a. Turn to ON position. b. Make sure all wire leads are tight and attached to proper terminals (see wiring diagram on page 3) c. See section 1a above d. Replace the valve
3. Log set not burning properly	<ul style="list-style-type: none"> a. Low flame/uneven flame 	<ul style="list-style-type: none"> a. Check for low gas pressure; should have operating pressures of 7" w.c.. for natural gas, 11" w.c. for propane at manifold b. Burner should be filled completely with sand or vermiculite (propane)
4. Log set operates but will not shut off	<ul style="list-style-type: none"> a. Toggle switch control lead wires to the valve may be shorted together or on wrong terminals 	<ul style="list-style-type: none"> a. See page 3 (wiring diagram)
5. Frequent pilot outage	<ul style="list-style-type: none"> a. Pilot flame is out of adjustment b. Down drafts from the chimney extinguishing the pilot 	<ul style="list-style-type: none"> a. See section 1b above b. Check draft. Consult with a qualified chimney expert
6. Logset shuts down during operation	<ul style="list-style-type: none"> a. Glass doors closed causing excessive heat buildup b. Pilot generator improperly mounted on rear of the burner pans c. Heatshield not in place 	<ul style="list-style-type: none"> a. Open glass doors b. See MOUNTING PILOT ASSEMBLY TO REAL-FRYE® BURNERS c. Place heatshield over the valve. Be sure the solid black face of the shield is between the valve and the burner

WARRANTY

PETERSON VENTED GAS LOG SETS LIMITED WARRANTY

All Peterson gas logs are **WARRANTED for as long as you own them (lifetime)**.

All Peterson burner assemblies are **WARRANTED for TEN (10) YEARS**.

SPK-26 controls are covered by a **THREE (3) YEAR "All Parts" Warranty**.

All other Peterson valves, pilots, and controls are covered by a **ONE (1) YEAR Limited Warranty (excluding batteries)**.

PLEASE KEEP A COPY OF YOUR SALES SLIP FOR PROOF OF PURCHASE

This warranty applies to the original purchaser and to single family residential use only. It commences from date of purchase, and is valid only with proof of purchase.

This warranty does not cover parts becoming defective through misuse, accidental damage, electrical damage, improper handling, storage, and/or installation. Product must be installed (and gas must be connected) as specified in the instructions or operator's manual, by a **qualified professional installer**. Accessories, parts, valves, remotes, etc., when used must be Peterson Co. product.

This warranty **does not** apply to rust, corrosion, oxidation, or discoloration, unless the affected component becomes inoperable. It **does not** cover labor or labor-related charges.

This warranty specifically excludes liability for **indirect, incidental**, or consequential damages. Some states do not allow the exclusion or limitation of incidental or consequential damages, so the above exclusion may not apply to you. This warranty gives you specified legal rights, and you may have other rights that may vary from state to state.

For additional information regarding this warranty, or to place a warranty claim, contact the R.H. Peterson dealer where the product was purchased.

**TO REGISTER YOUR PRODUCT ONLINE GO TO: WWW.RHPETERSON.COM,
AND CLICK ON PRODUCT REGISTRATION. THANK YOU FOR YOUR PURCHASE.**

ROBERT H. PETERSON CO.

Quality Check

Date: _____

Orifice # (Main): _____

Orifice # (Other): _____

Leak Test: _____

Burn Test: _____

Gas Type: NAT. / PROPANE

Model #: _____

Serial #: _____

Air Shutter: _____

Inspector: _____