

Model:  
Escape-36DV

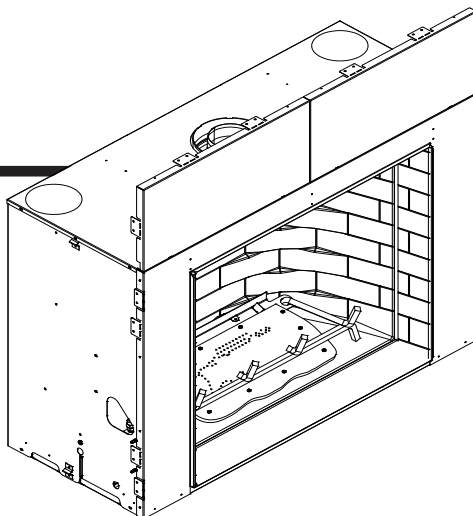

GAS-FIRED



### CAUTION



#### DO NOT DISCARD THIS MANUAL

- Important operating and maintenance instructions included.
- Read, understand and follow these instructions for safe installation and operation.
- Leave this manual with party responsible for use and operation.

DO NOT  
DISCARD

**⚠ WARNING:** If the information in these instructions is not followed exactly, a fire or explosion may result causing property damage, personal injury, or death.

- Do not store or use gasoline or other flammable vapors and liquids in the vicinity of this or any other appliance.
- **What to do if you smell gas**
  - Do not try to light any appliance
  - Do not touch any electrical switch. Do not use any phone in your building.
  - Immediately call your gas supplier from a neighbor's phone. Follow the gas supplier's instructions.
  - If you cannot reach your gas supplier, call the fire department.
- Installation and service must be performed by a qualified installer, service agency, or the gas supplier.

This appliance may be installed as an OEM installation in manufactured home (USA only) or mobile home and must be installed in accordance with the manufacturer's instructions and the manufactured home construction and safety standard, *Title 24 CFR, Part 3280 or Standard for Installation in Mobile Homes, CAN/CSA Z240MH*.

*This appliance is only for use with the type(s) of gas indicated on the rating plate.*

### ⚠ WARNING



#### HOT SURFACES!

Glass and other surfaces are hot during operation AND cool down.

#### Hot glass will cause burns.

- Do not touch glass until it is cooled
  - NEVER allow children to touch glass
  - Keep children away
  - CAREFULLY SUPERVISE children in same room as fireplace.
  - Alert children and adults to hazards of high temperatures.
- High temperatures may ignite clothing or other flammable materials.**
- Keep clothing, furniture, draperies and other flammable materials away.

***This appliance has been supplied with an integral barrier to prevent direct contact with the fixed glass panel. DO NOT operate the appliance with the barrier removed.***

Contact your dealer or Hearth & Home Technologies if the barrier is not present or help is needed to properly install one.

In the Commonwealth of Massachusetts:

- installation must be performed by a licensed plumber or gas fitter;
- See Table of Contents for location of additional Commonwealth of Massachusetts requirements.



Installation and service of this appliance should be performed by qualified personnel. Hearth & Home Technologies suggests NFI certified or factory trained professionals, or technicians supervised by an NFI certified professional.

Read this manual before installing or operating this appliance.  
Please retain this owner's manual for future reference.

## Congratulations

Congratulations on selecting a Heat & Glo gas appliance—an elegant and clean alternative to wood burning appliances. The Heat & Glo gas appliance you have selected is designed to provide the utmost in safety, reliability, and efficiency.

As the owner of a new appliance, you'll want to read and carefully follow all of the instructions contained in this *Owner's Manual*. Pay special attention to all Cautions and Warnings.

This *Owner's Manual* should be retained for future reference. We suggest that you keep it with your other important documents and product manuals.

The information contained in this *Owner's Manual*, unless noted otherwise, applies to all models and gas control systems.

Your new Heat & Glo gas appliance will give you years of durable use and trouble-free enjoyment. Welcome to the Heat & Glo family of appliance products!

<h3>Homeowner Reference Information</h3> <p>Model Name: _____ Date purchased/installed: _____</p> <p>Serial Number: _____ Location on appliance: _____</p> <p>Dealership purchased from: _____ Dealer Phone: _____</p> <p>Notes: _____</p> <p>_____</p>	<p><i>We recommend that you record the following pertinent information about your appliance.</i></p>
---	--

### Listing Label Information/Location

The model information regarding your specific appliance can be found on the rating plate usually located in the control area of the appliance.

Type of Gas →

Gas and Electric Information →

**HEAT & GLO**  
No one builds a better fire

Heat & Glo, a brand of Hearth & Home Technologies, Inc.  
7571 215th Street West, Lakeville, MN 55044

Not for use with solid fuel.  
*(Ne doit pas entre utilise avec un combustible solide).*

Type of Gas (Sorte De Gaz): **NATURAL GAS**

This appliance must be installed in accordance with local codes, if any; if not, follow ANSI Z223.1 in the USA or CAN/CGA B149 installation codes. (Installer l'appareil selon les codes ou reglements locaux ou, en l'absence de tels reglements, selon les codes d'installation CAN/CGA-B149.)

**ANSI Z21XX-XXXX · CSA 2.XX-MXX · UL307B**

Minimum Permissible Gas Supply for Purposes of Input Adjustment.		
Approved Minimum (De Gaz) Acceptable	0.0 in w.c.	(Po. Col. d'eau)
Maximum Pressure (Pression)	0.0 in w.c.	(Po. Col. d'eau)
Maximum Manifold Pressure (Pression)	0.0 in w.c.	(Po. Col. d'eau)
Minimum Manifold Pressure (Pression)	0.0 in w.c.	(Po. Col. d'eau)
Total Electrical Requirements: 000Vac, 00Hz., less than 00 Amperes		

**GAS-FIRED**

ALTITUDE:	0-0000 FT.	INCANADA	0000-0000FT.
MAX. INPUT BTUH:	00,000		00,000
MIN. INPUT BTUH:	00,000		00,000
ORIFICE SIZE:	#XXXXX		#XXXXX

<b>Model:</b> (Modele):	<b>XXXXXXXX</b>
<b>Serial</b> (Serie):	<b>XXXXXXXX</b>

Model Number →

Serial Number →

# Table of Contents

## 1 Listing and Code Approvals

A. Appliance Certification . . . . .	4
B. BTU Specifications . . . . .	4
C. High Altitude Installations . . . . .	4
D. Non-Combustible Materials Specification . . . . .	4
E. Combustible Materials Specification . . . . .	4
F. Electrical Codes . . . . .	4
G. Requirements for the Commonwealth of Massachusetts . . . . .	5

## 2 Getting Started

A. Design and Installation Considerations . . . . .	6
B. Tools and Supplies Needed . . . . .	6
C. Inspect Appliance and Components . . . . .	6
D. Inspect Firebox . . . . .	7

## 3 Framing and Clearances

A. Selecting Appliance Location . . . . .	8
B. Constructing the Appliance Chase . . . . .	9
C. Clearances . . . . .	9
D. Mantel Projections . . . . .	10
E. Hearth Extension . . . . .	10

## 4 Termination Locations

A. Vent Termination Minimum Clearances . . . . .	11
--	----

## 5 Vent Information and Diagrams

A. Vent Table Key . . . . .	13
B. Use of Elbows . . . . .	13
C. Measuring Standards . . . . .	13
D. Vent Diagrams . . . . .	14

## 6 Vent Clearances and Framing

A. Pipe Clearances to Combustibles . . . . .	19
B. Wall Penetration Framing . . . . .	19
C. Vertical Penetration Framing . . . . .	20

## 7 Appliance Preparation

A. Removing Non-combustible Facing Material Assembly . . . . .	21
B. Securing and Leveling the Appliance . . . . .	21
C. Installing Non-combustible Facing Material . . . . .	22

## 8 Installing Vent Pipe

A. Assembly of Vent Sections (DVP Pipe) . . . . .	23
B. Disassembly of Vent Sections . . . . .	25
C. Installing Heat Shield and Horizontal Termination Cap . . . . .	26
D. Installing Roof Flashing and Vertical Termination Cap . . . . .	27

## 9 Gas Information

A. Fuel Conversions . . . . .	29
B. Gas Pressures . . . . .	29
C. Gas Connection . . . . .	29

## 10 Electrical Information

A. Recommendation for Wire . . . . .	31
B. Connecting to the Appliance . . . . .	31
C. Intellifire Ignition System Wiring . . . . .	31
D. Junction Box Installation . . . . .	33

## 11 Finishing

A. Mantel Projections . . . . .	34
B. Facing Material . . . . .	34

## 12 Appliance Setup

A. Remove Shipping Materials . . . . .	36
B. Clean the Appliance . . . . .	36
C. Accessories . . . . .	36
D. Installing the Optional Heat-Zone-Gas Kit . . . . .	36
E. Ember Placement . . . . .	36
F. Positioning the Logs . . . . .	37 ←
G. Glass Assembly . . . . .	41
H. Grilles and Trim . . . . .	41
I. Air Shutter Setting . . . . .	41

## 13 Operating Instructions

A. Before Lighting Appliance . . . . .	42
B. Lighting Appliance . . . . .	43
C. After Appliance is Lit . . . . .	44
D. Frequently Asked Questions . . . . .	44

## 14 Troubleshooting

A. Intellifire Ignition System . . . . .	45
--	----

## 15 Maintaining and Servicing Appliance

A. Maintenance Tasks . . . . .	47
B. Replacing Light Bulb . . . . .	48

## 16 Reference Materials

A. Appliance Dimension Diagram . . . . .	50
B. Vent Components Diagrams . . . . .	51
C. Service Parts List . . . . .	58 ←
D. Limited Lifetime Warranty . . . . .	59
E. Contact Information . . . . .	61

→ = Contains updated information.

# 1 Listing and Code Approvals

## A. Appliance Certification

**MODELS:** Escape-36DV, Escape-36DVLP  
**LABORATORY:** Underwriters Laboratories, Inc. (UL)  
**TYPE:** Direct Vent Gas Appliance Heater  
**STANDARD:** ANSI Z21.88-2000 • CSA2.33-M98 • UL307B

This product is listed to ANSI standards for “Vented Gas Appliance Heaters” and applicable sections of “Gas Burning Heating Appliances for Manufactured Homes and Recreational Vehicles”, and “Gas Fired Appliances for Use at High Altitudes”.

**NOT INTENDED FOR USE AS A PRIMARY HEAT SOURCE.**  
 This appliance is tested and approved as either supplemental room heat or as a decorative appliance. It should not be factored as primary heat in residential heating calculations.

## B. BTU Specifications

Models (U.S. or Canada)		Maximum Input BTU/h	Minimum Input BTU/h	Orifice Size (DMS)
Escape-36DV	US (0-2000 FT)	41,000	27,000	30
	CANADA (2000-4500 FT)	36,900	24,300	31
Escape-36DVLP	US (0-2000 FT)	40,000	31,000	49
	CANADA (2000-4500 FT)	36,000	27,900	50

**Note:** This installation must conform with local codes. In the absence of local codes you must comply with the National Fuel Gas Code, ANSI Z223.1-latest edition in the U.S.A. and the CAN/CGA B149 Installation Codes in Canada.

## C. High Altitude Installations

U.L. Listed gas appliances are tested and approved without requiring changes for elevations from 0 to 2000 feet in the U.S.A. and Canada.

When installing this appliance at an elevation above 2000 feet, it may be necessary to decrease the input rating by changing the existing burner orifice to a smaller size. Input rate should be reduced by 4% for each 1000 feet above a 2000 foot elevation in the U.S.A., or 10% for elevations between 2000 and 4500 feet in Canada. If the heating value of the gas has been reduced, these rules do not apply. To identify the proper orifice size, check with the local gas utility.

If installing this appliance at an elevation above 4500 feet (in Canada), check with local authorities.

### WARNING

Do NOT use this appliance if any part has been under water. Immediately call a qualified service technician to inspect the appliance and to replace any part of the control system and any gas control which has been under water.

## D. Non-Combustible Materials Specification

Material which will not ignite and burn. Such materials are those consisting entirely of steel, iron, brick, tile, concrete, slate, glass or plasters, or any combination thereof.

Materials that are reported as passing **ASTM E 136, Standard Test Method for Behavior of Materials in a Vertical Tube Furnace at 750°C**, shall be considered non-combustible materials.

## E. Combustible Materials Specification

Materials made of or surfaced with wood, compressed paper, plant fibers, plastics, or other material that can ignite and burn, whether flame proofed or not, or whether plastered or unplastered shall be considered combustible materials.

## F. Electrical Codes

**NOTICE:** This appliance must be electrically wired and grounded in accordance with local codes or, in the absence of local codes, with **National Electric Code ANSI/NFPA 70-latest edition** or the **Canadian Electric Code CSA C22.1**.

- A 110-120 VAC circuit for this product must be protected with ground-fault circuit-interrupter protection, in compliance with the applicable electrical codes, when it is installed in locations such as in bathrooms or near sinks.

**Note:** The following requirements reference various Massachusetts and national codes not contained in this document.

## G. Requirements for the Commonwealth of Massachusetts

For all side wall horizontally vented gas fueled equipment installed in every dwelling, building or structure used in whole or in part for residential purposes, including those owned or operated by the Commonwealth and where the side wall exhaust vent termination is less than seven (7) feet above finished grade in the area of the venting, including but not limited to decks and porches, the following requirements shall be satisfied:

### Installation of Carbon Monoxide Detectors

At the time of installation of the side wall horizontal vented gas fueled equipment, the installing plumber or gas fitter shall observe that a hard wired carbon monoxide detector with an alarm and battery back-up is installed on the floor level where the gas equipment is to be installed. In addition, the installing plumber or gas fitter shall observe that a battery operated or hard wired carbon monoxide detector with an alarm is installed on each additional level of the dwelling, building or structure served by the side wall horizontal vented gas fueled equipment. It shall be the responsibility of the property owner to secure the services of qualified licensed professionals for the installation of hard wired carbon monoxide detectors.

In the event that the side wall horizontally vented gas fueled equipment is installed in a crawl space or an attic, the hard wired carbon monoxide detector with alarm and battery back-up may be installed on the next adjacent floor level.

In the event that the requirements of this subdivision can not be met at the time of completion of installation, the owner shall have a period of thirty (30) days to comply with the above requirements; provided, however, that during said thirty (30) day period, a battery operated carbon monoxide detector with an alarm shall be installed.

### Approved Carbon Monoxide Detectors

Each carbon monoxide detector as required in accordance with the above provisions shall comply with NFPA 720 and be ANSI/UL 2034 listed and IAS certified.

### Signage

A metal or plastic identification plate shall be permanently mounted to the exterior of the building at a minimum height of eight (8) feet above grade directly in line with the exhaust vent terminal for the horizontally vented gas fueled heating appliance or equipment. The sign shall read, in print size no less than one-half (1/2) inch in size, "**GAS VENT DIRECTLY BELOW. KEEP CLEAR OF ALL OBSTRUCTIONS**".

## Inspection

The state or local gas inspector of the side wall horizontally vented gas fueled equipment shall not approve the installation unless, upon inspection, the inspector observes carbon monoxide detectors and signage installed in accordance with the provisions of 248 CMR 5.08(2)(a)1 through 4.

## Exemptions

The following equipment is exempt from 248 CMR 5.08(2)(a)1 through 4:

- The equipment listed in Chapter 10 entitled "Equipment Not Required To Be Vented" in the most current edition of NFPA 54 as adopted by the Board; and
- Product Approved side wall horizontally vented gas fueled equipment installed in a room or structure separate from the dwelling, building or structure used in whole or in part for residential purposes.

## MANUFACTURER REQUIREMENTS

### Gas Equipment Venting System Provided

When the manufacturer of Product Approved side wall horizontally vented gas equipment provides a venting system design or venting system components with the equipment, the instructions provided by the manufacturer for installation of the equipment and the venting system shall include:

- Detailed instructions for the installation of the venting system design or the venting system components; and
- A complete parts list for the venting system design or venting system.

### Gas Equipment Venting System **NOT** Provided

When the manufacturer of a Product Approved side wall horizontally vented gas fueled equipment does not provide the parts for venting the flue gases, but identifies "special venting systems", the following requirements shall be satisfied by the manufacturer:

- The referenced "special venting system" instructions shall be included with the appliance or equipment installation instructions; and
- The "special venting systems" shall be Product Approved by the Board, and the instructions for that system shall include a parts list and detailed installation instructions.

A copy of all installation instructions for all Product Approved side wall horizontally vented gas fueled equipment, all venting instructions, all parts lists for venting instructions, and/or all venting design instructions shall remain with the appliance or equipment at the completion of the installation.

**See Gas Connection section for additional Commonwealth of Massachusetts requirements.**



## 2 Getting Started

### A. Design and Installation Considerations

Heat & Glo direct vent gas appliances are designed to operate with all combustion air siphoned from outside of the building and all exhaust gases expelled to the outside. No additional outside air source is required.

#### CAUTION

Check building codes prior to installation.

- Installation **MUST** comply with local, regional, state and national codes and regulations.
- Consult local building, fire officials or authorities having jurisdiction about restrictions, installation inspection, and permits.

When planning an appliance installation, it's necessary to determine the following information before installing:

- Where the appliance is to be installed.
- The vent system configuration to be used.
- Gas supply piping.
- Electrical wiring.
- Framing and finishing details.
- Whether optional accessories—devices such as a fan, wall switch, or remote control—are desired.



#### WARNING

- Keep appliance dry.
- Mold or rust may cause odors.
- Water may damage controls.



### B. Tools and Supplies Needed

Before beginning the installation be sure that the following tools and building supplies are available.

- |  |  |
|--|--|
| Reciprocating saw  | Framing material                                     |
| Pliers   | Noncorrosive leak check solution                     |
| Hammer   | Gloves   |
| Phillips screwdriver   | Framing square                                       |
| Flat blade screwdriver                                       | Electric drill and bits (1/4 in.)                    |
| Plumb line   | Safety glasses                                       |
| Level  | 1/2 - 3/4 inch length, #6 or #8 Self-drilling screws |
| Manometer  | Voltmeter  |
| Tape measure   |  |
| Caulking material (300°F minimum continuous exposure rating) |  |
| One 1/4 inch female connection (for optional fan).           |  |

### C. Inspect Appliance and Components



#### WARNING

Inspect appliance and components for damage. Damaged parts may impair safe operation.

- Do NOT install damaged components.
  - Do NOT install incomplete components.
  - Do NOT install substitute components.
- Report damaged parts to dealer.



- Carefully remove the appliance and components from the packaging.
- The vent system components and trim doors are shipped in separate packages.
- The gas logs may be packaged separately and must be field installed.
- Report to your dealer any parts damaged in shipment, particularly the condition of the glass.
- **Read all of the instructions before starting the installation. Follow these instructions carefully during the installation to ensure maximum safety and benefit.**



#### WARNING

Hearth & Home Technologies disclaims any responsibility for, and the warranty will be voided by, the following actions:

- Installation and use of any damaged appliance or vent system component.
- Modification of the appliance or vent system.
- Installation other than as instructed by Hearth & Home Technologies.
- Improper positioning of the gas logs or the glass door.
- Installation and/or use of any component part not approved by Hearth & Home Technologies.

**Any such action may cause a fire hazard.**

## D. Inspect Firebox

Surface cracking or crazing of firebrick material is normal and expected. The following types of cracks are acceptable and do not require replacement of the unit or the firebox:

- Cracks that do not propagate entirely through the material.
- Light fracture lines or “spider-webbing” on the surface of the material.
- Cracks that are less than 1/32 in. wide and less than 3 in. long.
- If cosmetically unacceptable, such cracks may be repaired with the SRV-PACK service kit. See Service Parts List.

Cracks that are unacceptable:

- Cracks greater than 1/32 in. wide and 3 in. long are at risk of growing.
- Cracks that penetrate entirely through the firebrick material.

Inspection for cracking should be run when the appliance is cool. Cracks tend to close as the appliance heats up.

# 3 Framing and Clearances

**Note:**

- Illustrations reflect typical installations and are FOR DESIGN PURPOSES ONLY.
- Illustrations/diagrams are not drawn to scale.
- Actual installation may vary due to individual design preference.

## A. Selecting Appliance Location

When selecting a location for your appliance it is important to consider the required clearances to walls (see figure 3.1).

### ⚠ WARNING



**Fire Risk**

Provide adequate clearance:

- Around air openings
- To combustibles
- For service access

Locate appliance away from traffic areas.

**Note:** For actual appliance dimensions refer to Section 16.

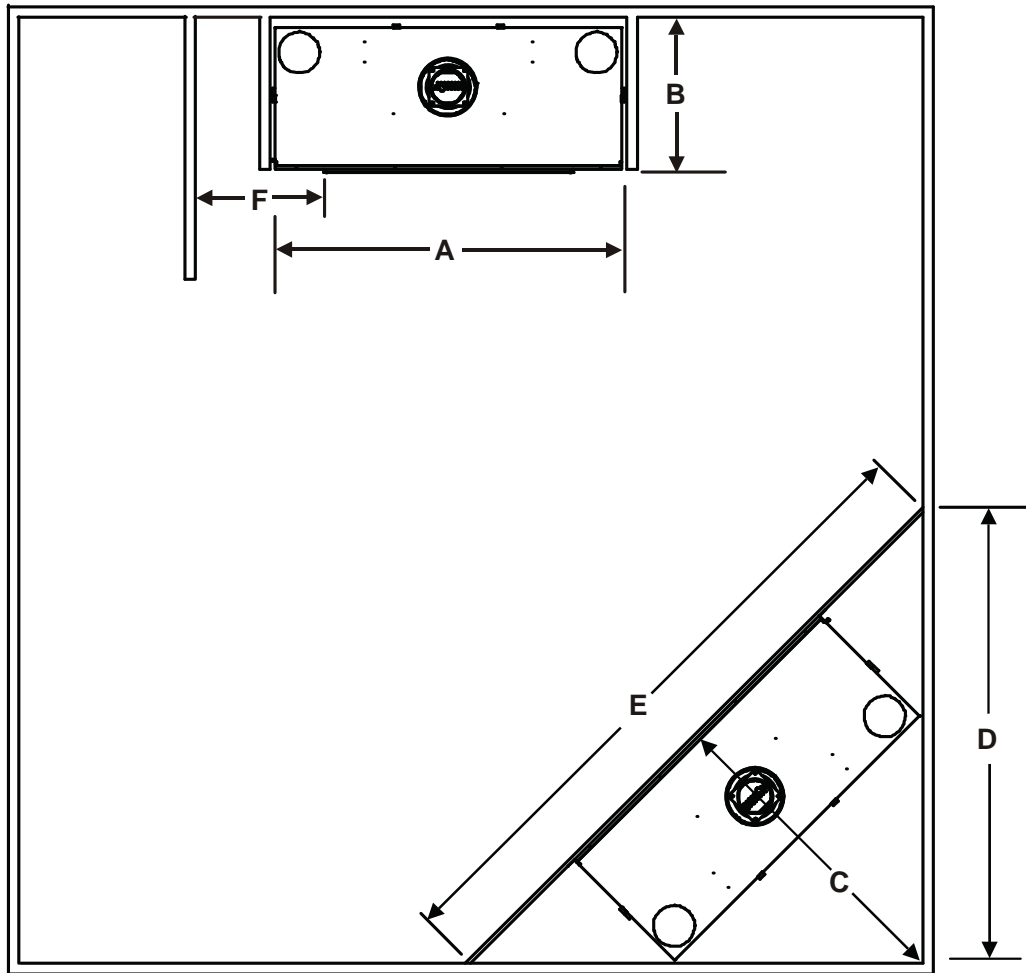

In addition to these framing dimensions, also reference the following sections:

- Clearances and Mantel Projections (**Sections 3.C and 3.D**)
- Vent Clearances and Framing (**Section 6**).

	A	B	C	D	E	F
Inches	51-1/2	22	46-3/4	66	93-3/8	7-1/2
Millimeters	1308	559	1187	1676	2372	190

Figure 3.1 Appliance Locations



## B. Constructing the Appliance Chase

A chase is a vertical boxlike structure built to enclose the gas appliance and/or its vent system. Vertical vents that run on the outside of a building may be, but are not required to be, installed inside a chase.

Construction of the chase may vary with the type of building. These instructions are not substitutes for the requirements of local building codes. Local building codes **MUST** be checked.

Chases should be constructed in the manner of all outside walls of the home to prevent cold air drafting problems. The chase should not break the outside building envelope in any manner.

Walls, ceiling, base plate and cantilever floor of the chase should be insulated. Vapor and air infiltration barriers should be installed in the chase as per regional codes for the rest of the home. Additionally, in regions where cold air infiltration may be an issue, the inside surfaces may be sheetrocked and taped for maximum air tightness.

To further prevent drafts, the wall shield and ceiling firestops should be caulked with caulk with a minimum of 300°F continuous exposure rating to seal gaps. Gas line holes and other openings should be caulked with caulk with a minimum of 300°F continuous exposure rating or stuffed with unfaced insulation. If the appliance is being

installed on a cement surface, a layer of plywood may be placed underneath to prevent conducting cold up into the room.

## C. Clearances

**⚠ WARNING**

Fire Risk.  
Odor Risk.

- Install appliance on hard metal or wood surfaces extending full width and depth of appliance.
- Do NOT install appliance directly on carpeting, vinyl, tile or any combustible material other than wood.

**⚠ WARNING**

Fire Risk.

- Construct chase to all clearance specifications in manual.
- Locate and install appliance to all clearance specifications in manual.

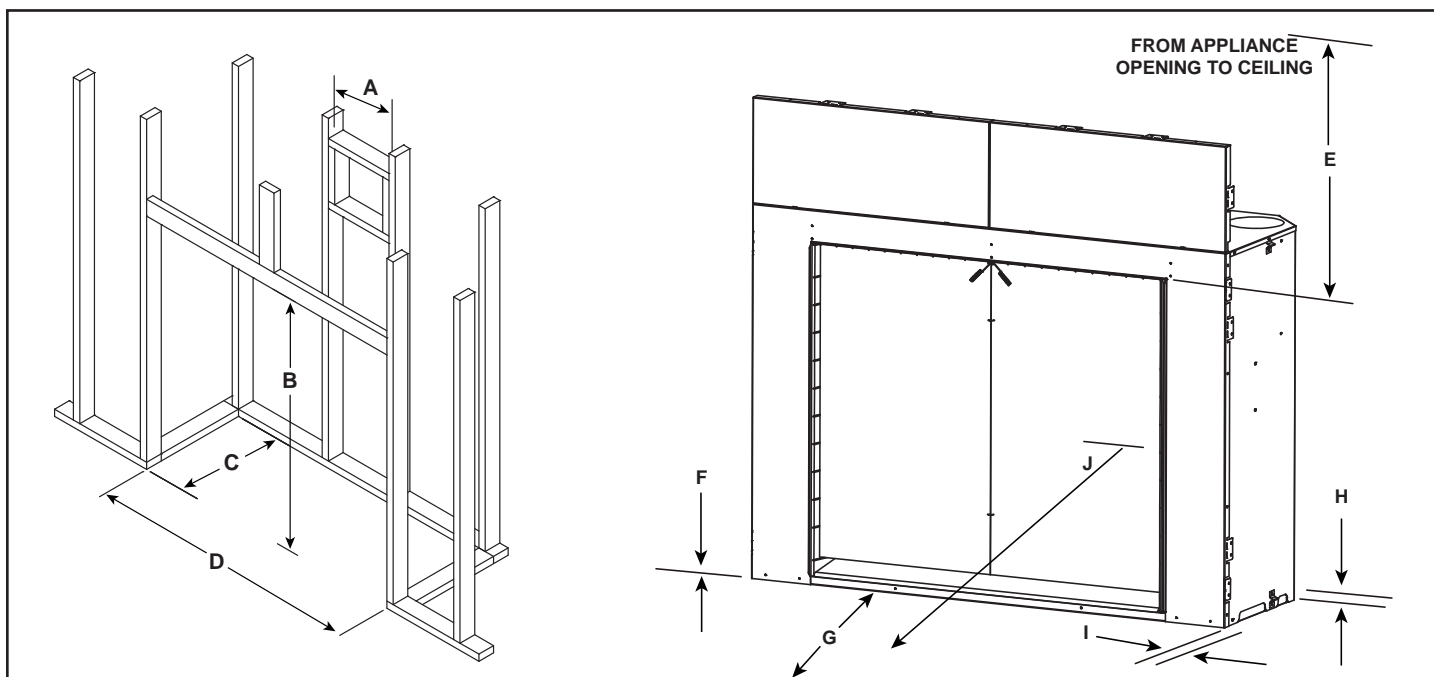

CLEARANCES TO COMBUSTIBLES										
	A	B	C	D	E	F	G	H	I	J
	Rough Opening (Vent Pipe)	Rough Opening (Height)	Rough Opening (Depth)	Rough Opening (Width)	Clearance to Ceiling	Combustible Floor	Combustible Flooring	Behind Appliance	Sides of Appliance	Front of Appliance
<i>Inches</i>	10	46	22	51-1/2	34-1/2	0	12	1/2	1/2	36
<i>mm</i>	254	1168	559	1308	876	0	305	13	13	914

Figure 3.2 Clearances to Combustibles

## D. Mantel Projections

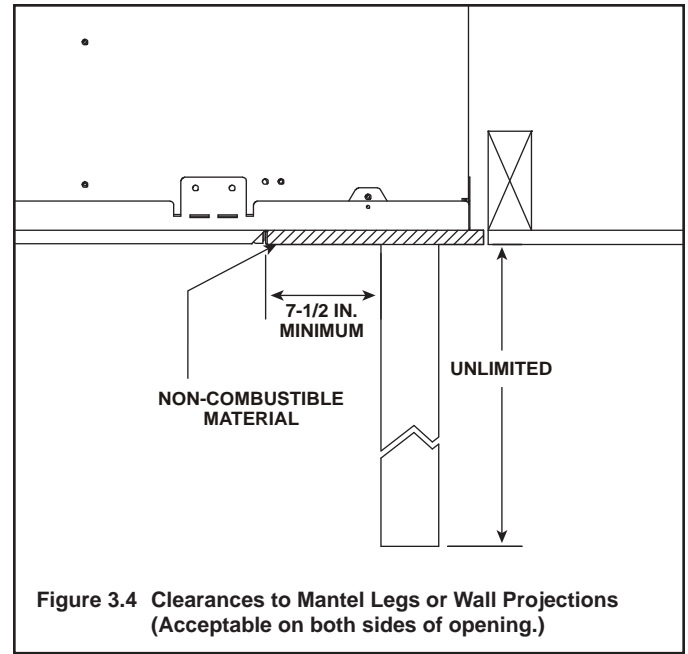
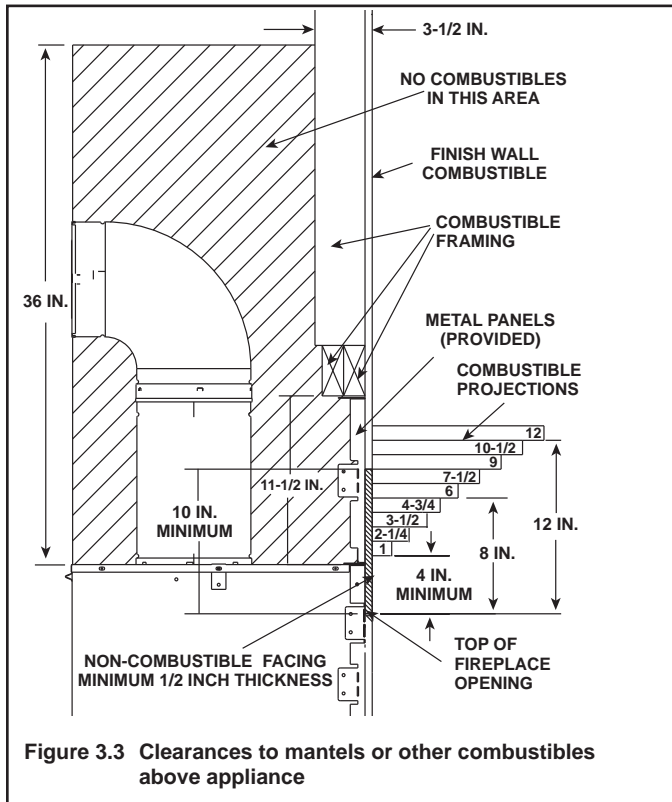

Height Above Opening	Horizontal Mantel Distance
4 in.	1 in.
5 in.	2-1/4 in.
6 in.	3-1/2 in.
7 in.	4-3/4 in.
8 in.	6 in.
9 in.	7-1/2 in.
10 in.	9 in.
11 in.	10-1/2 in.
12 in.	12 in.

**⚠ WARNING**

**Fire Risk.**  
Hearth extension required to protect combustible floors in front of appliance.

- An 12 inch minimum hearth extension must be constructed of non-combustible material.

## E. Hearth Extension

The base of the fireplace may sit on a combustible surface. The area in front of the fireplace must be protected by a non-combustible hearth extension, unless the fireplace is raised a minimum of 3 inches above the combustible floor or hearth. See figures 3.5 and 3.6.

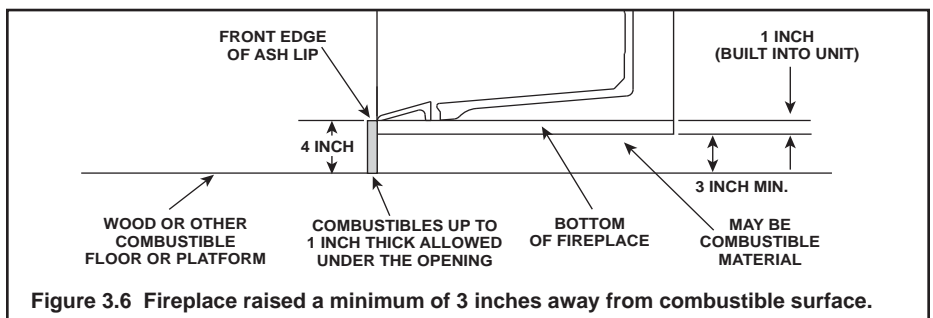
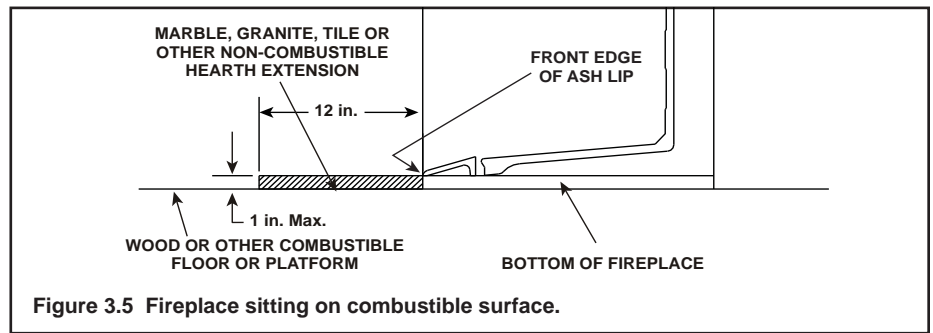

# 4 Termination Locations

## A. Vent Termination Minimum Clearances

**⚠ WARNING**



Fire Risk.  
Explosion Risk.  
Inspect external vent cap regularly.

- Ensure no debris blocks cap.
- Combustible materials blocking cap may ignite.
- Restricted air flow affects burner operation.



**⚠ WARNING**



Fire Risk.  
Explosion Risk.  
Maintain vent clearance to combustibles as specified.

- Do not pack air space with insulation or other materials.



Failure to keep insulation or other materials away from vent pipe may cause fire.

Measure vertical clearances from this surface.

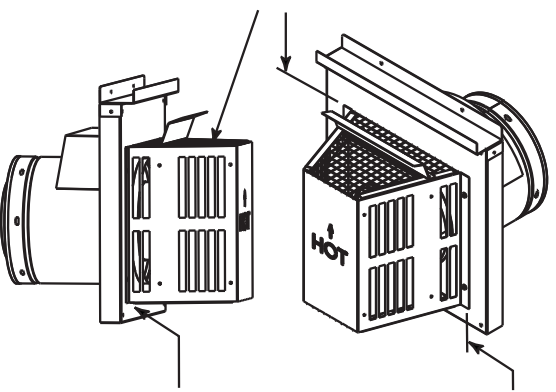

Measure horizontal clearances from this surface.

(See Figure 4.4 for specific clearances)

**Figure 4.1**

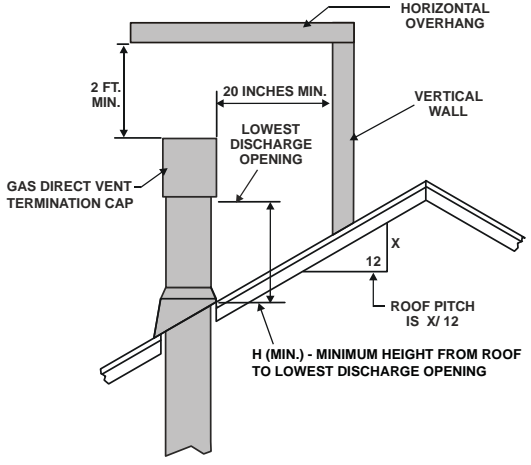

Roof Pitch	H (Min.) Ft.
Flat to 6/12	1.0*
Over 6/12 to 7/12	1.25*
Over 7/12 to 8/12	1.5*
Over 8/12 to 9/12	2.0*
Over 9/12 to 10/12	2.5
Over 10/12 to 11/12	3.25
Over 11/12 to 12/12	4.0
Over 12/12 to 14/12	5.0
Over 14/12 to 16/12	6.0
Over 16/12 to 18/12	7.0
Over 18/12 to 20/12	7.5
Over 20/12 to 21/12	8.0

\* 3 foot minimum in snow regions

**Figure 4.2 Minimum height from roof to lowest discharge opening**

Figure 4.2 specifies minimum vent heights for various pitched roofs.

A	B
6 in. (minimum) up to 20 in. 152 mm/508 mm	18 in. minimum 457 mm
20 in. and over	0 in. minimum

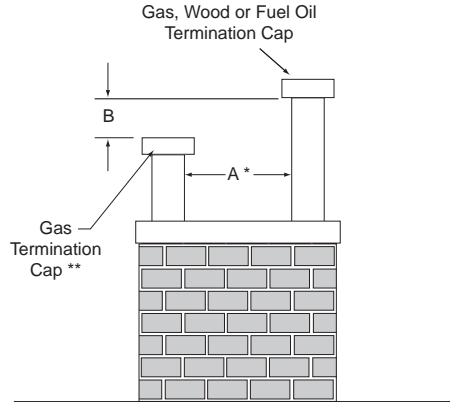

\* If using decorative cap cover(s), this distance may need to be increased. Refer to the installation instructions supplied with the decorative cap cover.

\*\* In a staggered installation with both gas and wood or fuel oil terminations, the wood or fuel oil termination cap must be higher than the gas termination cap.

**Figure 4.3 Multiple Vertical Termination**

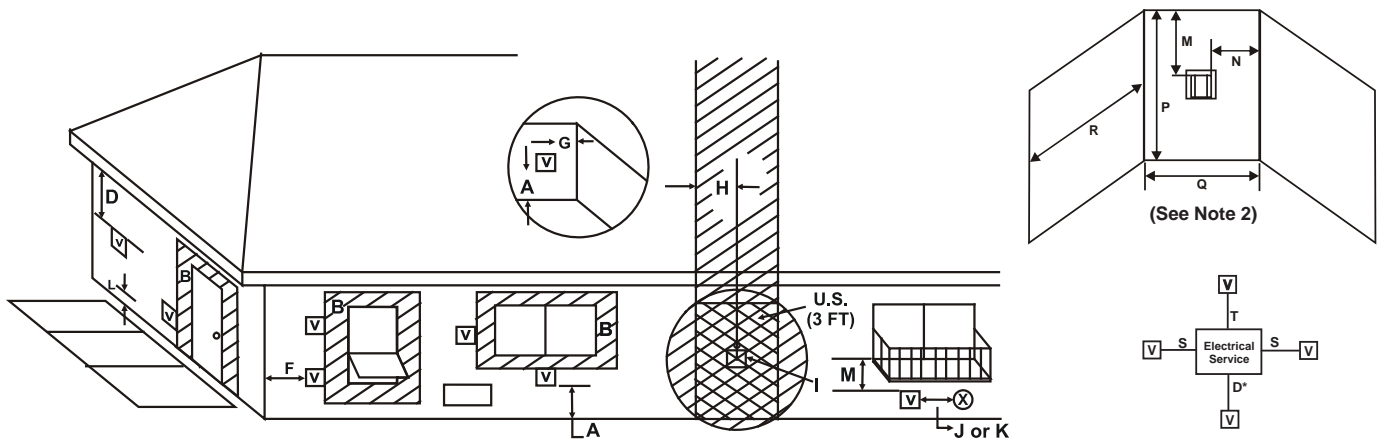

**V** = VENT TERMINAL      **X** = AIR SUPPLY INLET      **Hatched Area** = AREA WHERE TERMINAL IS NOT PERMITTED

- |  |  |
|--|--|
| <p>A = 12 inches.....clearances above grade, veranda, porch, deck or balcony<br/>(See Note 1)</p> <p>B = 12 inches.....clearances to window or door that may be opened, or to permanently closed window. (Glass)</p> <p>D* = 22 inches.....vertical clearance to unventilated soffit or to ventilated soffit located above the terminal<br/>*42 inches.....for vinyl clad soffits and below electrical service</p> <p>F = 9 inches.....clearance to outside corner</p> <p>G = 6 inches.....clearance to inside corner</p> <p>H = 3 ft. (Canada).....not to be installed above a gas meter/regulator assembly within 3 feet (90 cm) horizontally from the center-line of the regulator</p> <p>I = 3 ft.....clearance to gas service regulator vent outlet</p> <p>J = 9 inches (U.S.A.)<br/>12 inches (Canada) clearance to non-mechanical air supply inlet to building or the combustion air inlet to any other appliance</p> <p>K = 3 ft. (U.S.A.)<br/>6 ft. (Canada).....clearance to a mechanical (powered) air supply inlet</p> | <p>L** = 7 ft..... clearance above paved sidewalk or a paved driveway located on <b>public</b> property<br/>(See Note 1)</p> <p>M*** = 18 inches..... clearance under veranda, porch, deck, balcony or overhang<br/>42 inches ..... vinyl</p> <p>S = 6 inches.....clearance from sides of electrical service<br/>(See Note 5)</p> <p>T = 12 inches.....clearance above electrical service<br/>(See Note 5)</p> |
|--|--|

**Alcove Applications**

N = 6 inches .....non-vinyl sidewalls  
12 inches .....vinyl sidewalls

P = 8 ft.

	$Q_{MIN}$	$R_{MAX}$
1 cap	3 feet	$2 \times Q_{ACTUAL}$
2 caps	6 feet	$1 \times Q_{ACTUAL}$
3 caps	9 feet	$2/3 \times Q_{ACTUAL}$
4 caps	12 feet	$1/2 \times Q_{ACTUAL}$
$Q_{MIN} = \# \text{ termination caps} \times 3$ $R_{MAX} = (2 / \# \text{ termination caps}) \times Q_{ACTUAL}$		

\*\* a vent shall not terminate directly above a sidewalk or paved driveway which is located between two single family dwellings and serves both dwellings.

\*\*\* only permitted if veranda, porch, deck or balcony is fully open on a minimum of 2 sides beneath the floor, or meets Note 2.

**Note 1:** On private property where termination is less than 7 feet above a sidewalk, driveway, deck, porch, veranda or balcony, use of a listed cap shield is suggested. (See vents components page)

**Note 2:** Termination in an alcove space (spaces open only on one side and with an overhang) are permitted with the dimensions specified for vinyl or non-vinyl siding and soffits. **1.** There must be 3 feet minimum between termination caps. **2.** All mechanical air intakes within 10 feet of a termination cap must be a minimum of 3 feet below the termination cap. **3.** All gravity air intakes within 3 feet of a termination cap must be a minimum of 1 foot below the termination cap.

**Note 3:** Local codes or regulations may require different clearances.

**Note 4:** Termination caps may be hot. Consider their proximity to doors or other traffic areas.

**Note 5:** Location of the vent termination must not interfere with access to the electrical service.

**WARNING: In the U.S:** Vent system termination is **NOT** permitted in screened porches. You must follow side wall, overhang and ground clearances as stated in the instructions.

**In Canada:** Vent system termination is **NOT** permitted in screened porches. Vent system termination is permitted in porch areas with two or more sides open. You must follow all side walls, overhang and ground clearances as stated in the instructions.

Heat & Glo assumes no responsibility for the improper performance of the appliance when the venting system does not meet these requirements.

**Figure 4.4 Minimum Clearances for Termination**

**CAUTION: IF EXTERIOR WALLS ARE FINISHED WITH VINYL SIDING, IT IS SUGGESTED THAT A VINYL PROTECTOR KIT BE INSTALLED.**

# 5 Vent Information and Diagrams

## A. Vent Table Key

The abbreviations listed in this vent table key are used in the vent diagrams.

Symbol	Description
V <sub>1</sub>	First section (closest to appliance) of vertical length
V <sub>2</sub>	Second section of vertical length
H <sub>1</sub>	First section (closest to appliance) of horizontal length
H <sub>2</sub>	Second section of horizontal length

### ⚠ WARNING



Fire Hazard.

Explosion Risk.

Asphyxiation Risk.

Do NOT connect this gas appliance to a chimney flue serving a separate solid-fuel or gas burning appliance.



- Vent this appliance directly outside.
  - Use separate vent system for this appliance.
- May impair safe operation of this appliance or other appliances connected to the flue.

## B. Use of Elbows

### CAUTION

ALL vent configuration specifications MUST be followed.

- This product is tested and listed to these specifications.
- Appliance performance will suffer if specifications are not followed.

Diagonal runs have both vertical and horizontal vent aspects when calculating the effects. Use the rise for the vertical aspect and the run for the horizontal aspect (see Figure 5.1).

Two 45° elbows may be used in place of one 90° elbow. On 45° runs, one foot of diagonal is equal to 8.5 inches horizontal run and 8.5 inches vertical run. A length of straight pipe is allowed between two 45° elbows (see Figure 5.1).

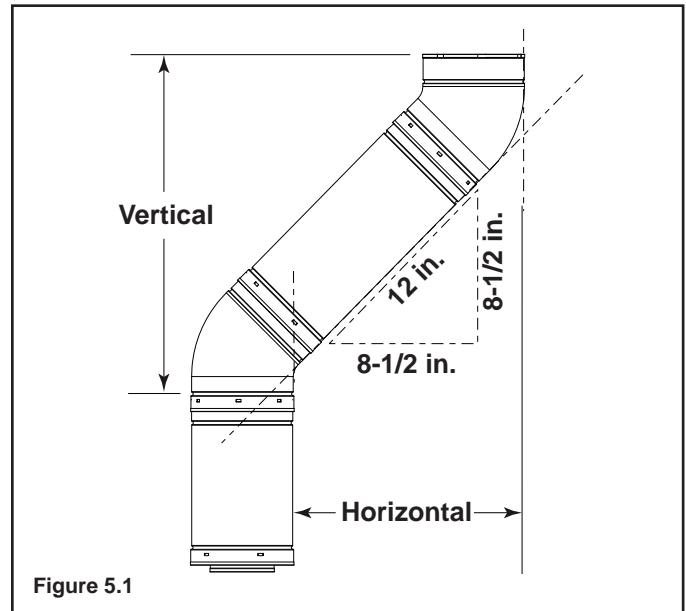

Figure 5.1

## C. Measuring Standards

Vertical and horizontal measurements listed in the vent diagrams were made using the following standards.

1. Pipe measurements are shown using the effective length of pipe (see Figure 5.2).
2. Measurements are made from the appliance outer wrap, not from the standoffs.
3. Horizontal terminations are measured to the outside mounting surface (flange of termination cap) (see Figure 4.1).
4. Vertical terminations are measured to bottom of termination cap.
5. Horizontal pipe installed level with no rise.

Pipe	Effective Length	
	Inches	Millimeters
DVP4	4	102
DVP6	6	152
DVP12	12	305
DVP24	24	610
DVP36	36	914
DVP48	48	1219
DVP6A	3 to 6	76 to 152
DVP12A	3 to 12	76 to 305
DVP12MI	3 to 12	76 to 305
DVP24MI	3 to 24	76 to 610

Figure 5.2 DVP Pipe Effective Length

## D. Vent Diagrams

### ⚠ WARNING



Fire Risk. Explosion Risk.

Do NOT pack insulation or other combustibles between ceiling firestops.

- ALWAYS maintain specified clearances around venting and firestop systems.
- Install wall shield and ceiling firestops as specified.

Failure to keep insulation or other material away from vent pipe may cause fire.



## 1. Top Vent - Horizontal Termination

### One Elbow

**Note:** Must have a 12 inches minimum vertical vent before attaching any elbow to the unit.

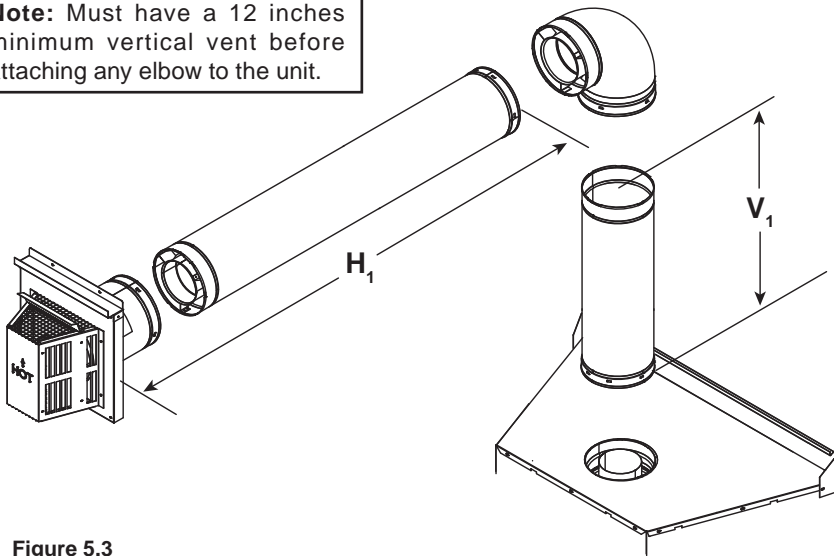

Figure 5.3

V <sub>1</sub> Minimum		H <sub>1</sub> Maximum	
1 ft.	305 mm	1-1/2 ft.	457 mm
1-1/2 ft.	457 mm	2 ft.	610 mm
2 ft.	610 mm	5 ft.	1524
3 ft.	914 mm	8 ft.	2438
4 ft.	1219 mm	11 ft.	3353
5 ft.	1524 mm	14 ft.	4267
6 ft.	1829 mm	17 ft.	5182
7 ft.	2134 mm	20 ft.	6096
8 ft.	2438 mm	23 ft.	7010
V <sub>1</sub> + H <sub>1</sub> = 63 ft. (19.2 m) Maximum			

### Two Elbows

**Note:** Must have a 12 inches minimum vertical vent before attaching any elbow to the unit.

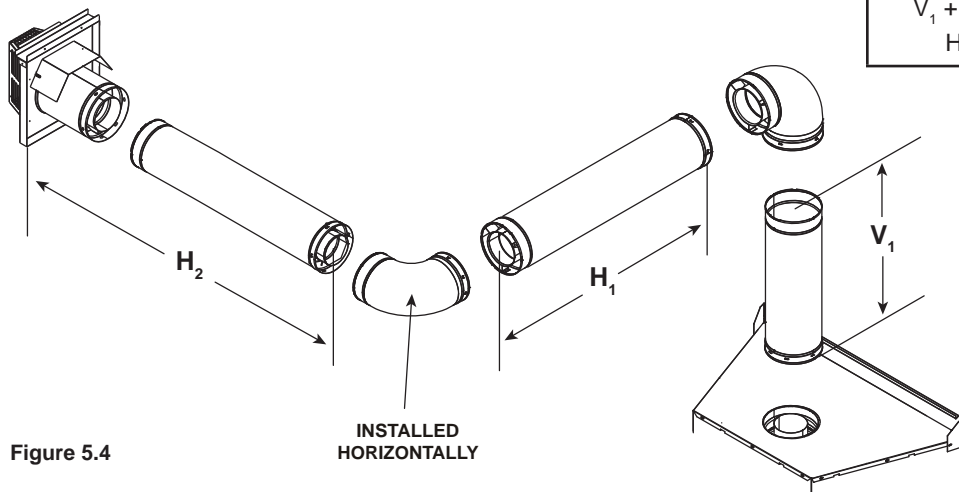

Figure 5.4

V <sub>1</sub> Minimum		H <sub>1</sub> + H <sub>2</sub> Maximum	
1 ft.	305 mm	2 ft.	610 mm
1-1/2 ft.	457 mm	2-1/2 ft.	762 mm
2 ft.	610 mm	5-1/2 ft.	1676 mm
3 ft.	914 mm	8-1/2 ft.	2591 mm
4 ft.	1219 mm	11-1/2 ft.	3505 mm
V <sub>1</sub> + H <sub>1</sub> + H <sub>2</sub> = 63 ft. (19.2 m) Maximum			
H <sub>1</sub> + H <sub>2</sub> = 23 ft. (7.1 m) Maximum			



# 1. Top Vent - Horizontal Termination - (continued)

## Three Elbows

**Note:** Must have a 12 inches minimum vertical vent before attaching any elbow to the unit.

V <sub>1</sub> + V <sub>2</sub> Minimum		H Maximum	
1-1/2 ft.	457 mm	1-1/2 ft.	457 mm
2 ft.	610 mm	2 ft.	610 mm
2-1/2 ft.	762 mm	5 ft.	1524
3-1/2 ft.	1067 mm	8 ft.	2438
4-1/2 ft.	1372 mm	11 ft.	3353
V <sub>1</sub> + V <sub>2</sub> + H <sub>1</sub> + H <sub>2</sub> = 63 ft. (19.2 m) Maximum H <sub>1</sub> + H <sub>2</sub> = 23 ft. (7.1 m) Maximum			

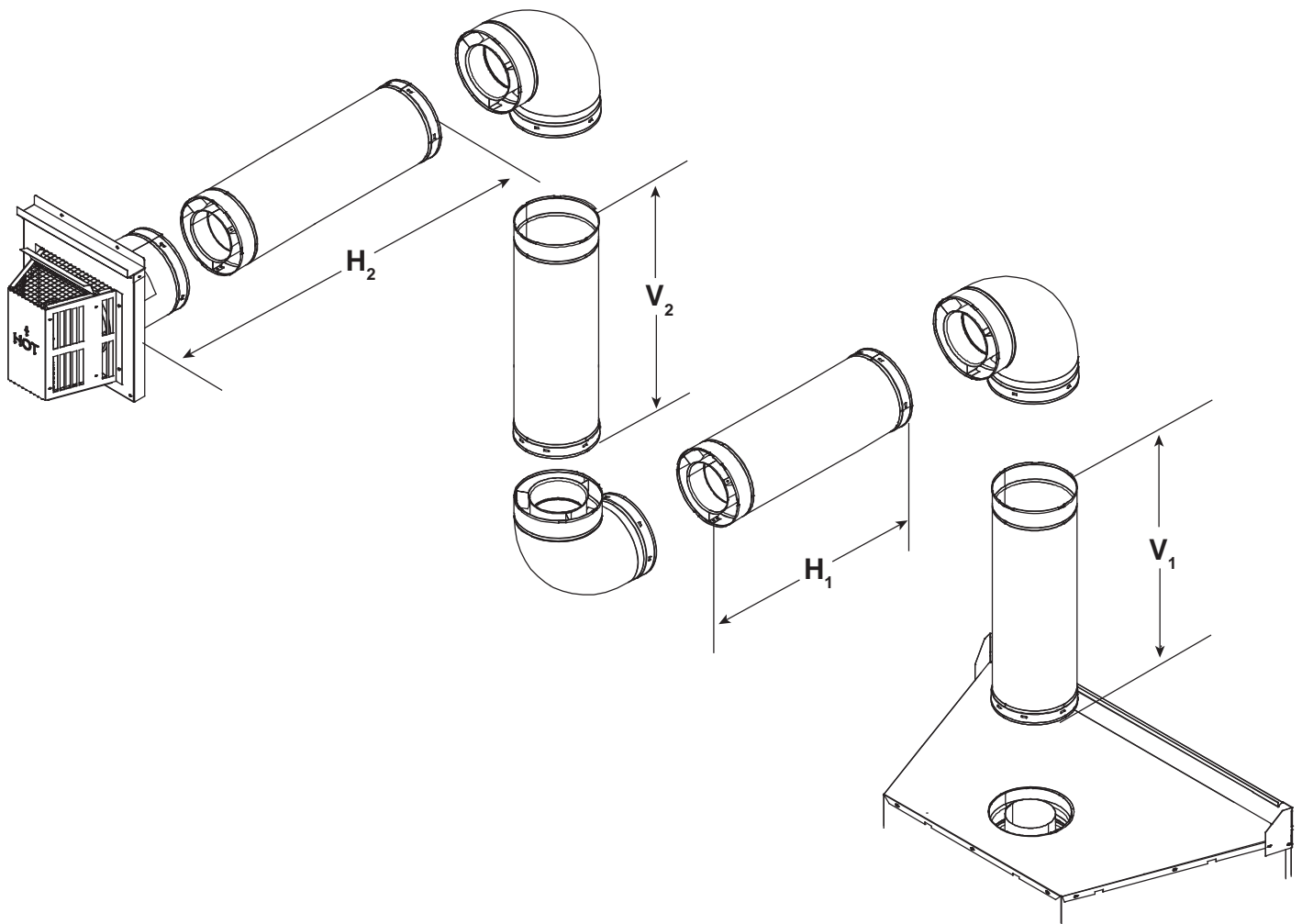
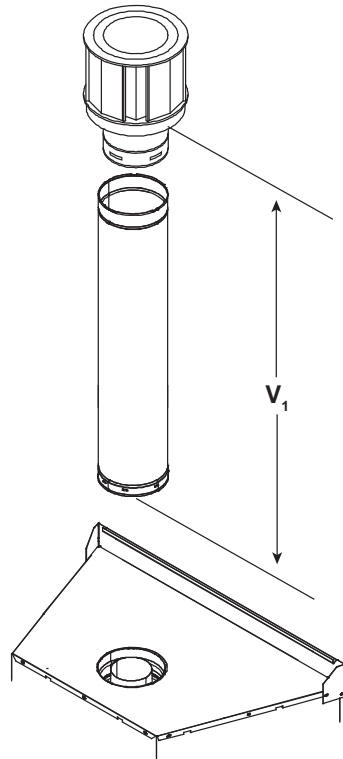

Figure 5.5

## 2. Top Vent - Vertical Termination

No Elbow



$V_1 = 40 \text{ ft. Max. (12.2 m)}$

**Note:** On vertical venting configurations install the flue restrictor (located behind the right side panel) per the following flue restrictor instructions.

Figure 5.6

### Flue Restrictor Instructions

1. The flue restrictor (Figure 5.7) is located behind the right side panel. Use the restrictor if the vertical vent run is over 20 feet and has NO elbows.

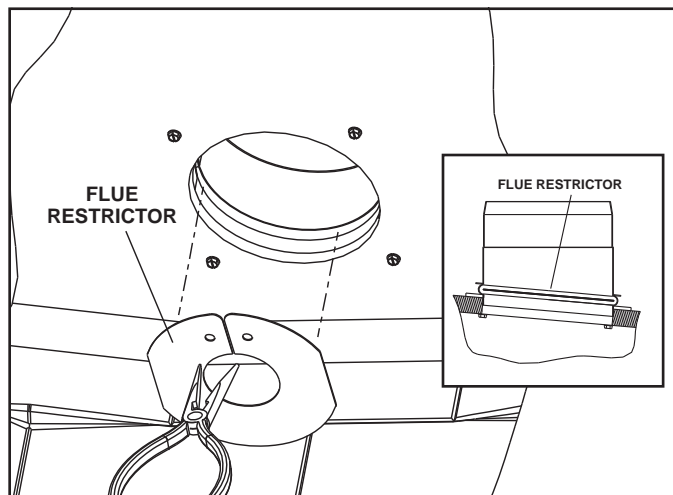

Figure 5.7

2. The restrictor sits inside the 5" diameter collar in the bead area. Using a needle-nose pliers, insert the tips of the pliers into the two holes in the restrictor plate. Squeeze the pliers to flex the plate. The edges of the plate will need to overlap each other. Insert the plate into the 5" collar from inside the firebox. Release the pliers, the plate will expand into the bead (groove) inside the collar. Make sure the plate is fully in the groove so the restrictor cannot fall out (see Figure 5.8).

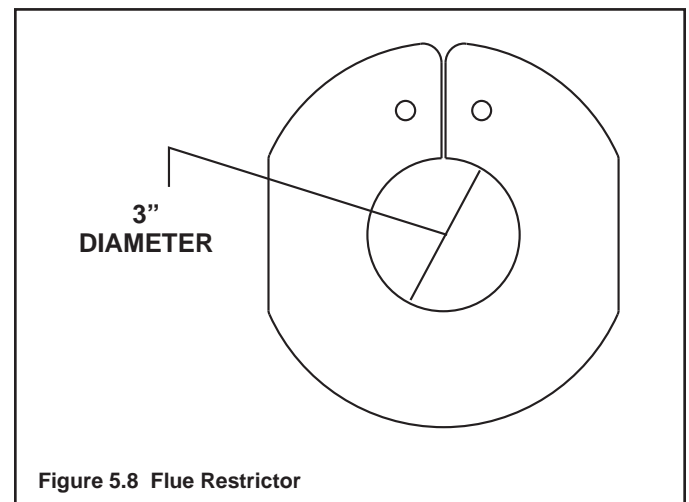

Figure 5.8 Flue Restrictor

## Two Elbows

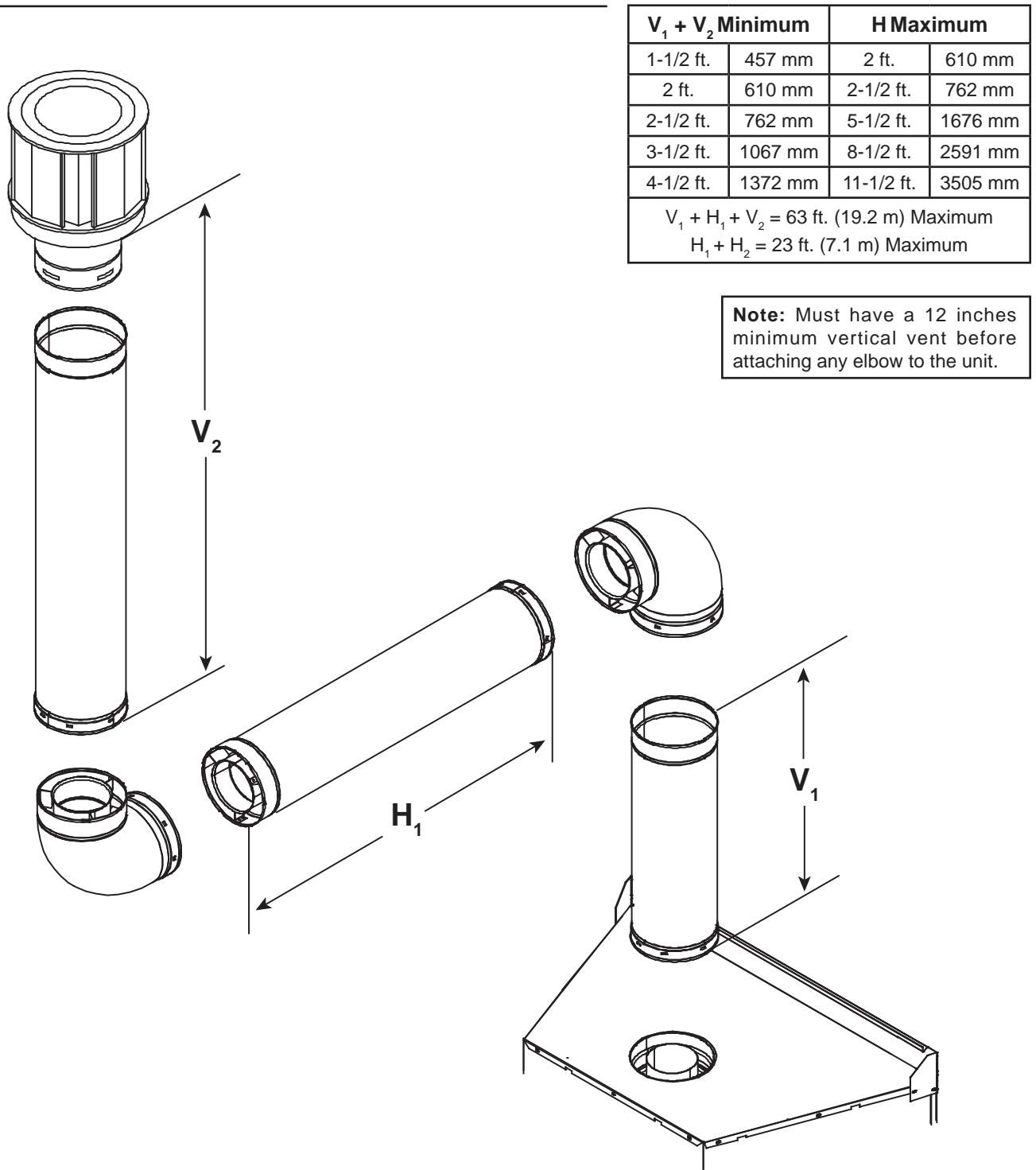
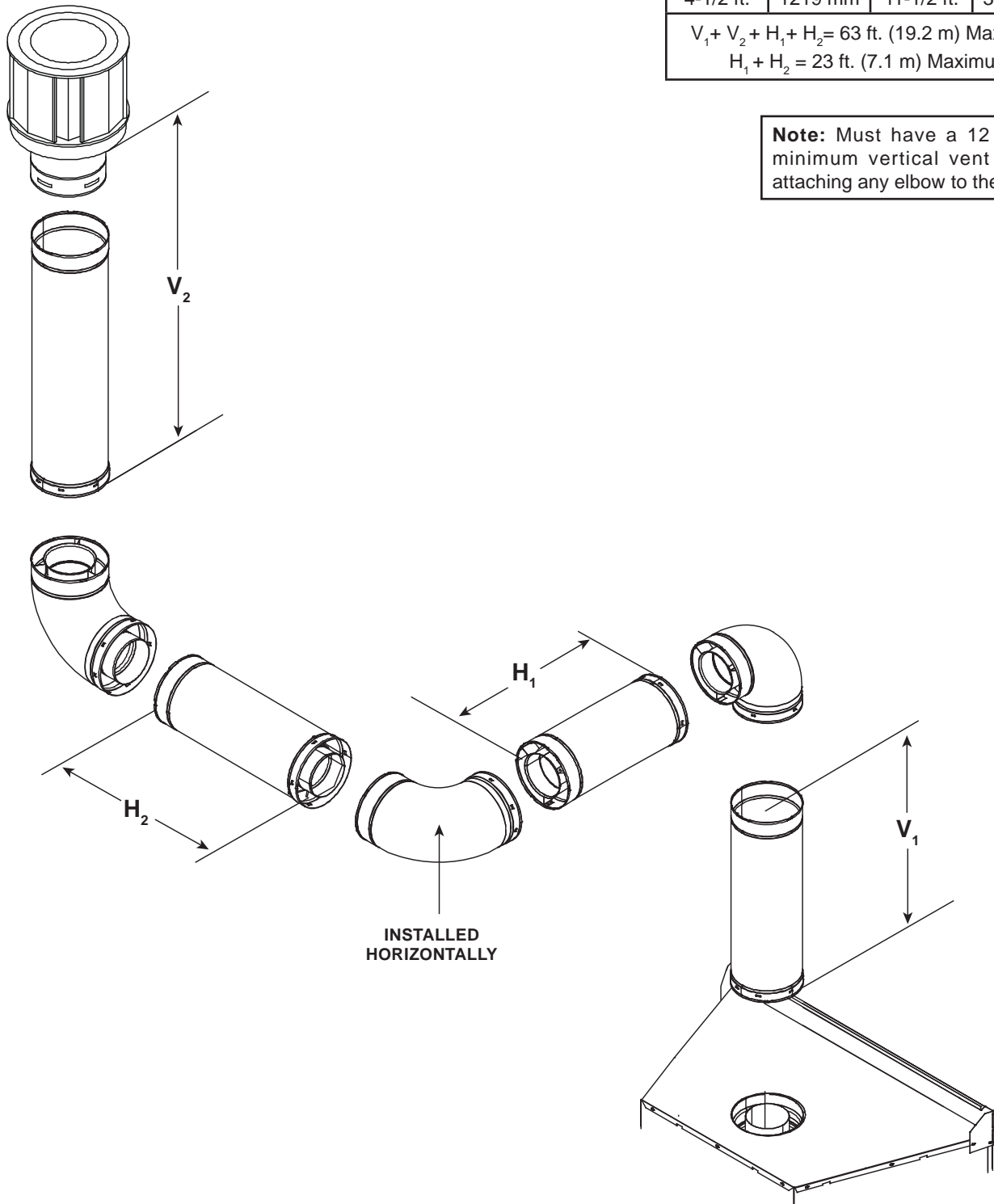

Figure 5.9

## 2. Top Vent - Vertical Termination - (continued)

### Three Elbows



$V_1 + V_2$ Minimum		$H_1 + H_2$ Maximum	
1-1/2 ft.	305 mm	2 ft.	610 mm
2 ft.	457 mm	2-1/2 ft.	762 mm
2-1/2 ft.	610 mm	5-1/2 ft.	1676 mm
3-1/2 ft.	914 mm	8-1/2 ft.	2591 mm
4-1/2 ft.	1219 mm	11-1/2 ft.	3505 mm
$V_1 + V_2 + H_1 + H_2 = 63$ ft. (19.2 m) Maximum $H_1 + H_2 = 23$ ft. (7.1 m) Maximum			

**Note:** Must have a 12 inches minimum vertical vent before attaching any elbow to the unit.

Figure 5.10

# 6 Vent Clearances and Framing

## A. Pipe Clearances to Combustibles

**⚠ WARNING**

Fire Risk.  
Explosion Risk.

Maintain vent clearance to combustibles as specified.

- Do not pack air space with insulation or other materials.

Failure to keep insulation or other materials away from vent pipe may cause fire.

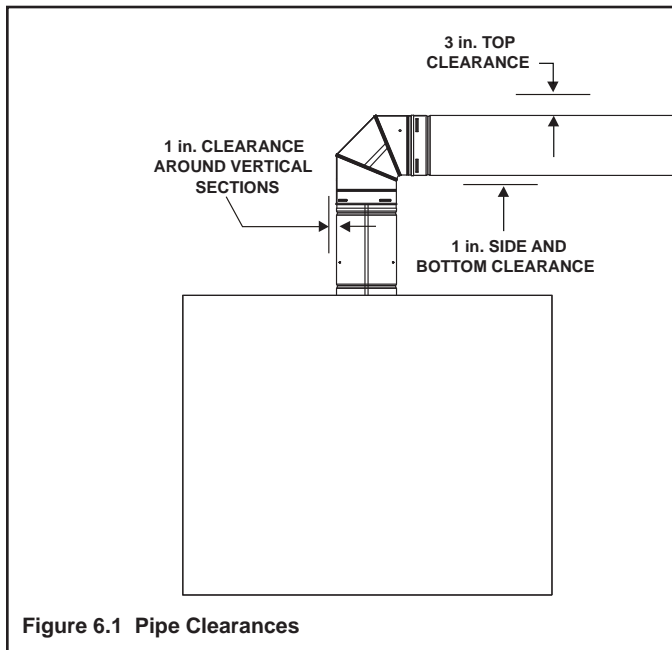

Figure 6.1 Pipe Clearances

**NOTE:** Heat shields **MUST** overlap by a minimum of 1-1/2 in. (38 mm). The heat shield is designed to be used on a wall 4 in. to 7-1/4 in. (102 mm to 184 mm) thick. If wall thickness is less than 4 in. (102 mm) the existing heat shields must be field trimmed. If wall thickness is greater than 7-1/4 in. (184 mm) a DVP-HSM-B will be required.

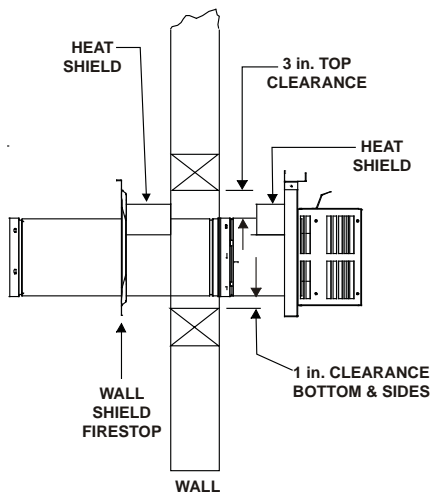

Figure 6.2 Horizontal Venting Clearances to Combustible Materials

## B. Wall Penetration Framing

### Combustible Wall Penetration

Frame a hole in a combustible wall for an interior wall shield firestop, (Figure 6.3) whenever a wall is penetrated. Use same size framing materials as those used in the wall construction. The wall shield firestop maintains minimum clearances and prevents cold air infiltration.

### Non-Combustible Wall Penetration

If the hole being penetrated is surrounded by noncombustible materials such as concrete, a hole with diameter one inch greater than the pipe is acceptable.

Whenever a non-combustible wall is penetrated, the wall shield firestop is only required on one side and no heat shield is necessary.

If your local inspector requires the wall shield firestop on both sides, then both wall shield firestops must have a heat shield attached to them.

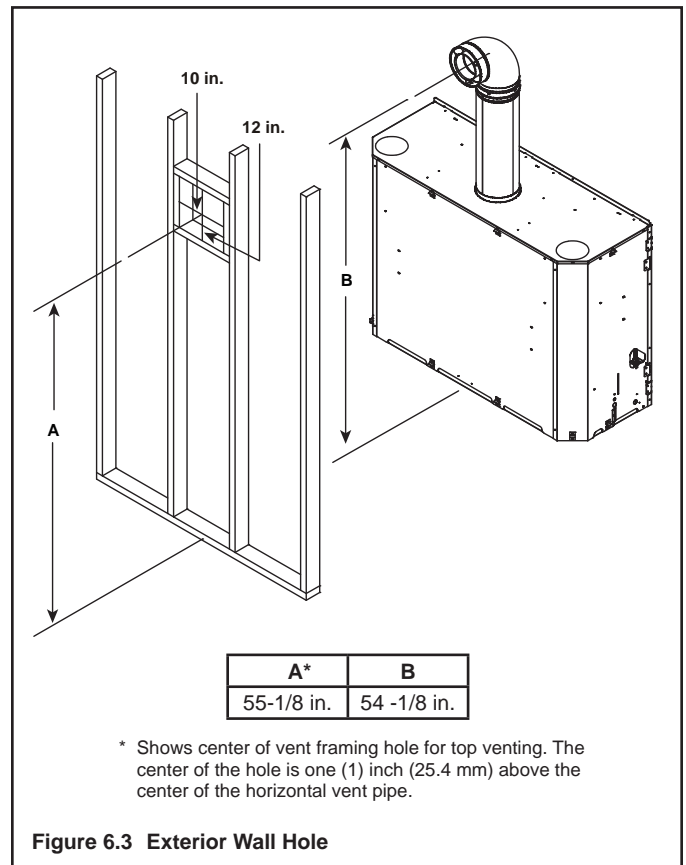

Figure 6.3 Exterior Wall Hole

## C. Vertical Penetration Framing

### ⚠ WARNING



#### Fire Hazard

Keep loose materials or blown insulation from touching the vent pipe.

- National building codes recommend using attic shield to keep loose materials/blown insulation from contacting vent.
- Hearth & Home Technologies requires the use of an attic shield.

### Installing the Ceiling Firestop

- Frame an opening 10 inches by 10 inches whenever the vent system penetrates a ceiling/floor (see Figure 6.4).
- Frame the area with the same sized lumber as used in ceiling/floor joist.
- When installing a top vent vertical termination appliance the hole should be directly above the appliance, unless the flue is offset.
- Do not pack insulation around the vent. Insulation must be kept away from the pipe.

### Installing Attic Shield

**Note:** An additional ceiling firestop is not required if attic shield is used.

- Frame opening for attic shield.
- Attic shield may be installed above or below ceiling (see Figure 6.5).
- Secure with three fasteners on each side.
- Fold tabs at top of attic shield in toward vent pipe. Tabs must keep vent pipe centered within shield.
- Field construct additional shield height if insulation is deeper than height of attic shield.

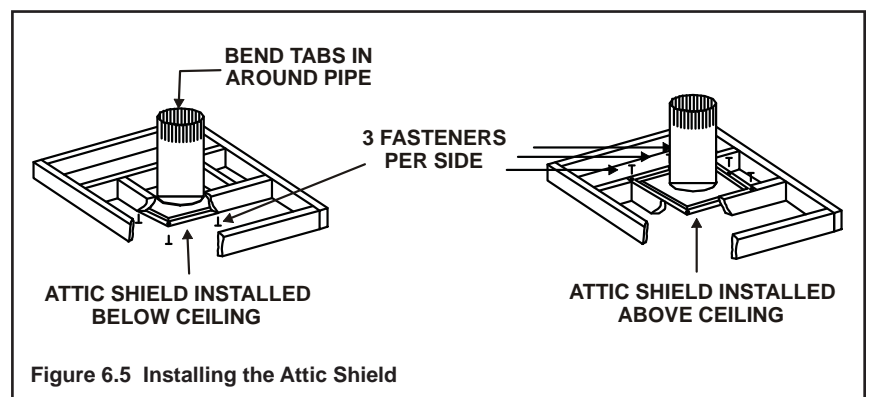
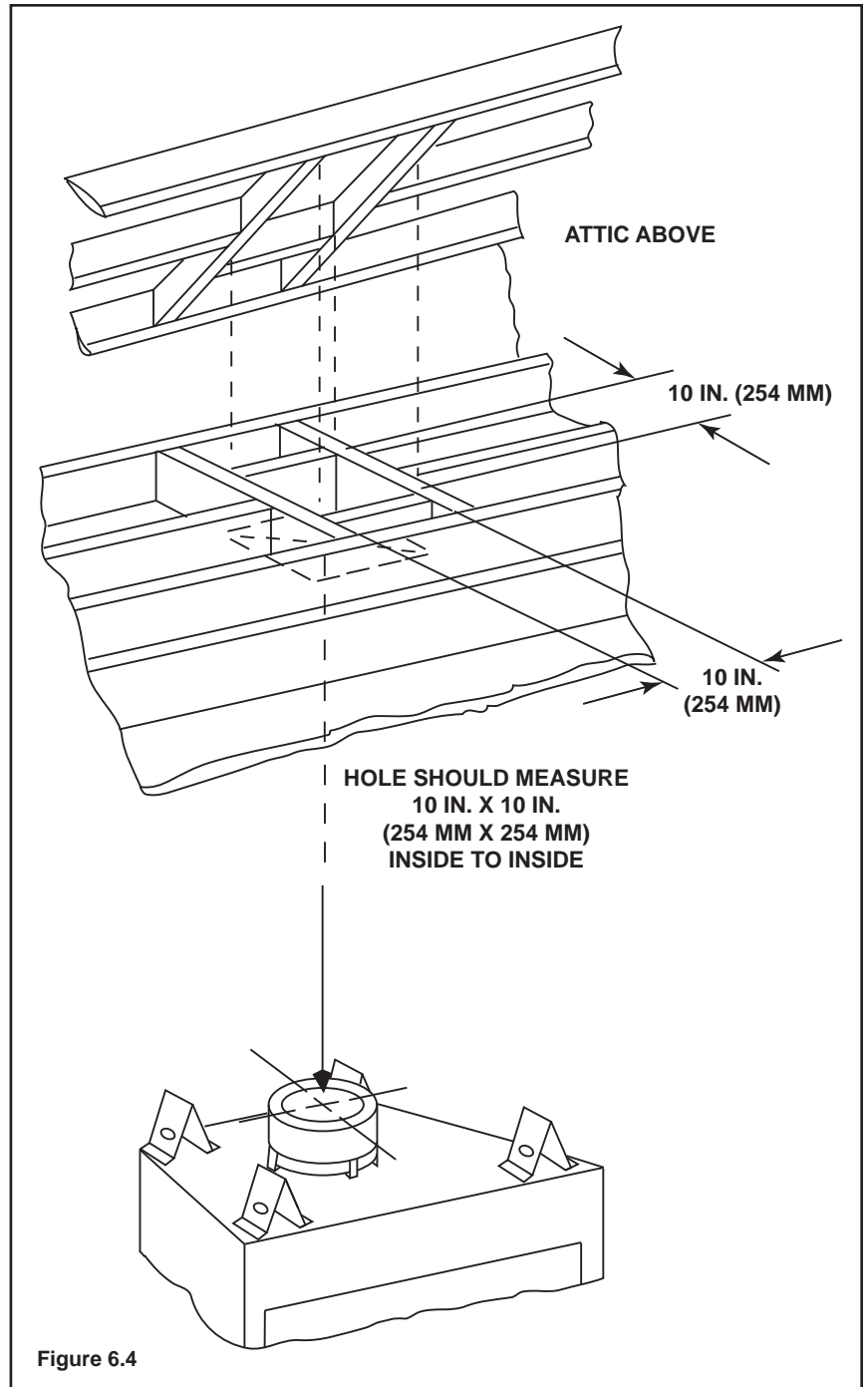



# 7 Appliance Preparation

## A. Removing Non-combustible Facing Material Assembly

The non-combustible assembly is located on the right side of appliance.

### CAUTION

- Handle with care.
- Non-combustible material may be damaged if dropped.

- Hold non-combustible pieces in place.
- Remove and save two screws from upper bracket.
- Remove non-combustible pieces.
- Remove and save three screws from lower bracket.
- Discard brackets.
- Replace screws in holes where brackets were attached to appliance.

## B. Securing and Leveling the Appliance

### ⚠ WARNING



- Fire Risk.
- Prevent contact with sagging, loose insulation.
  - Do NOT install against combustible materials such as exposed insulation, plastic and insulation backer.



### CAUTION

- Sharp Edges
- Wear protective gloves and safety glasses during installation.

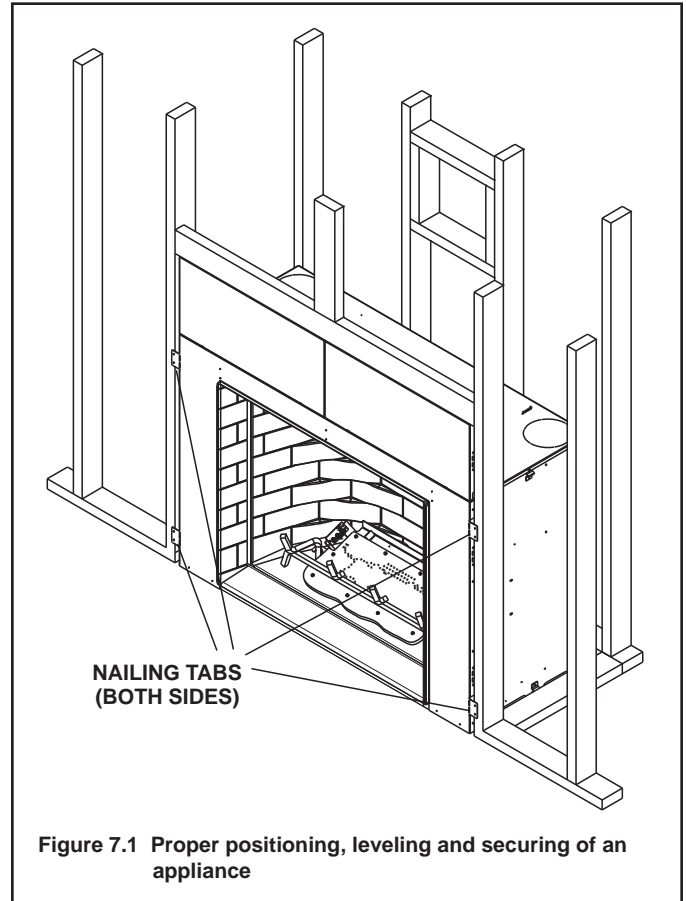

Figure 7.1 Proper positioning, leveling and securing of an appliance

### ⚠ WARNING

- Fire Risk.
- ALWAYS maintain specified clearances around the appliance.
  - Do NOT notch into the framing around the appliance spacers.
- Failure to keep insulation, framing or other material away from the appliance may cause fire.



The diagram shows how to properly position, level, and secure the appliance (see Figure 7.1). Nailing tabs are provided to secure the appliance to the framing members.

- Place the appliance into position.
- Level the appliance from side to side and front to back.
- Shim the appliance, as necessary. It is acceptable to use wood shims.
- Use the forward set of nailing tabs. Bend out nailing tabs on each side.
- Keep nailing tabs flush with the framing.
- Secure the appliance to the framing by using nails or screws through the nailing tabs.

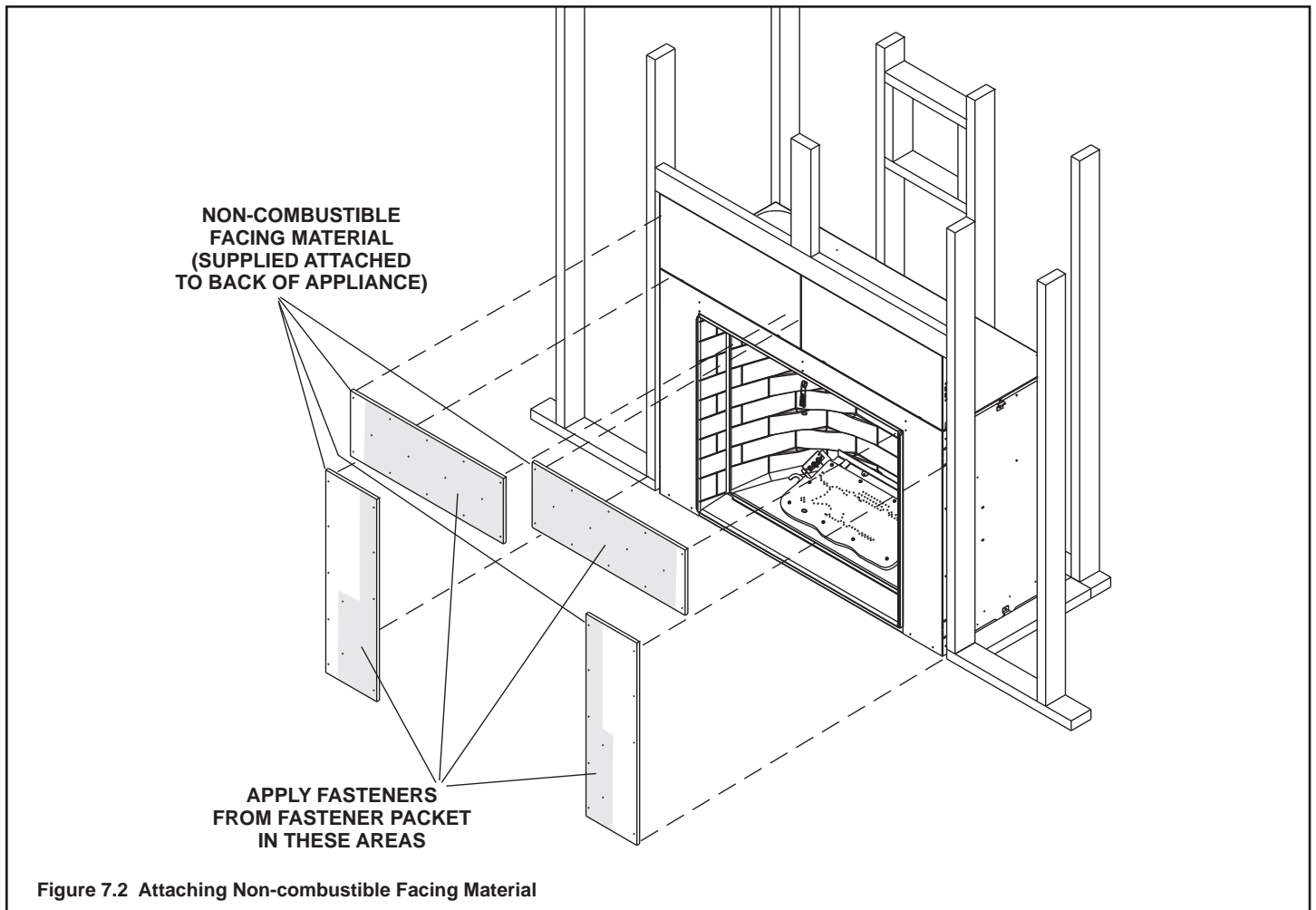



Figure 7.2 Attaching Non-combustible Facing Material

### C. Installing Non-combustible Facing Material

<b>⚠ WARNING</b>	
	<p>Fire Risk.</p> <ul style="list-style-type: none"> <li>• Follow these instructions exactly.</li> <li>• Facing materials must be installed properly to prevent fire.</li> <li>• No materials may be substituted without authorization by Hearth &amp; Home Technologies.</li> </ul>

- Center and attach two top boards to the framing members. See Figure 7.2.
- Attach left and right side pieces to framing members.
- Use fasteners from fastener packet (in manual bag) in shaded areas.
- Use regular sheetrock screws in non-shaded areas.
- Use a wet or dry towel or soft brush to remove dust or dirt from facing material.
- Apply a non-combustible adhesive to attach tile, stone or other non-combustible finishing materials per manufacturer's instructions.

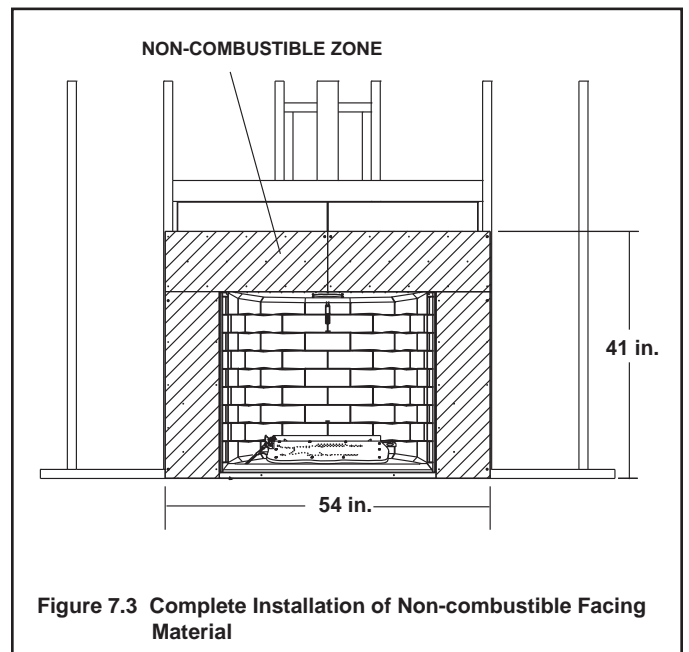



Figure 7.3 Complete Installation of Non-combustible Facing Material

# 8 Installing Vent Pipe

## A. Assembly of Vent Sections (DVP Pipe)

	<b>⚠ WARNING</b>	
Do not mix pipe, fittings or joining methods from different manufacturers.		

<b>⚠ WARNING</b>
 <p>Fire Risk Exhaust Fumes Risk Impaired Performance of Appliance</p> <ul style="list-style-type: none"> <li>• Overlap pipe slip sections at least 1-1/2 inches.</li> <li>• Use pilot holes for screws.</li> <li>• Screws must not exceed one inch long.</li> <li>• Pipe may separate if not properly joined.</li> </ul>

### Attaching Vent to the Firebox Assembly



To attach the first pipe section to the collars, slide the male end of the inner vent of the pipe section over the inner collar on the firebox assembly. At the same time, slide the outer flue over the outer collar on the appliance. Push the pipe section into the appliance collar until all the lances (see Figure 8.1) have snapped in place. Tug slightly on the section to confirm it has completely locked into place.

### Commercial, Multi-family (Multi-level exceeding two stories), & High-Rise Applications

For Installation into Commercial, multi-family (multi-level exceeding two stories) or high-rise applications: All pipe joints must be sealed with high temperature silicone, including the slip section that connects directly to the horizontal termination cap.

- Apply a bead of silicone sealant inside the female outer pipe joint prior to joining sections. See Figure 8.1
- Only outer pipes are sealed. Do not seal the inner flue. All unit collar, pipe, slip section, elbow and cap outer flues shall be sealed in this manner, unless otherwise stated.

**Note:** The end of the pipe sections with the lances/tabs on it will face toward the appliance.

	<b>⚠ WARNING</b>	
<p>Fire Risk Explosion Risk</p> <p>If slip section seals are broken during the removal of the termination cap, gas will leak and a fire or explosion may occur.</p> <p>Do not break silicone seals on slip sections.</p>		

### Assembling Pipe Sections

Insert the inner flue of section A into the flared inner flue of section B.

Start the outer flue of section A over the outer flue of section B (see Figure 8.2). **Note:** The end of the pipe sections with the lances/tabs on it will face towards the appliance. Once both inner and outer flues are started, press section A onto section B firmly until all lances have snapped into place. Check to make sure they have snapped together (see Figure 8.3) and the seams are not aligned (see Figure 8.4). Tug slightly on section A to confirm it has completely locked into place. It is acceptable to use screws no longer than 1 inch to hold outer pipe sections together. If predrilling holes, do NOT penetrate inner pipe.

For 90° and 45° elbows that are changing the vent direction from horizontal to vertical, one screw minimum should be put in the outer flue at the horizontal elbow joint to prevent the elbow from rotating. Use screws no longer than 1 inch. If predrilling screw holes, do NOT penetrate inner pipe.

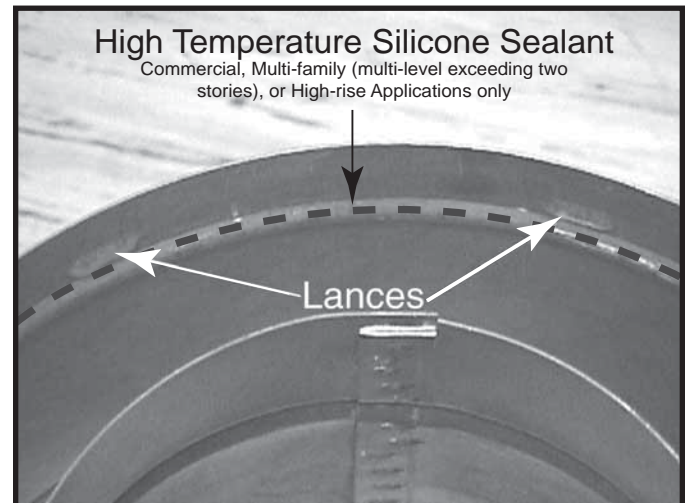

Figure 8.1 Lances

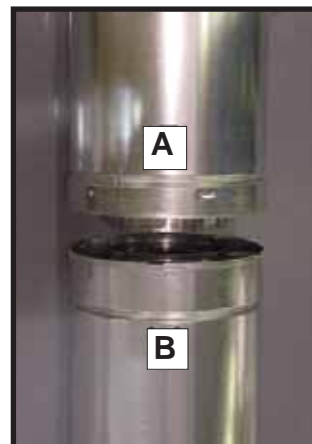
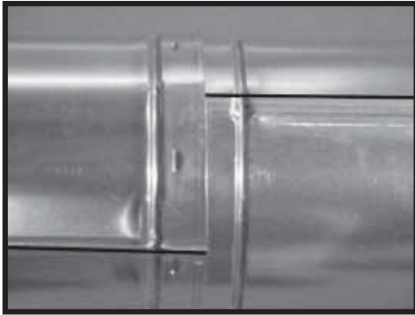

Figure 8.2

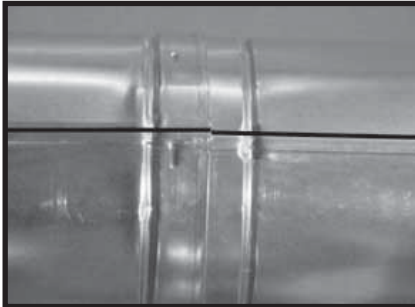

Figure 8.3

**Note:** Make sure that the seams are not aligned to prevent unintentional disconnection.



**CORRECT**



**INCORRECT**

Figure 8.4 Seams

This will secure the slip section to the desired length and prevent it from separating. The slip section can then be attached to the next pipe section.

If the slip section is too long, the inner and outer flues of the slip section can be cut to the desired length.

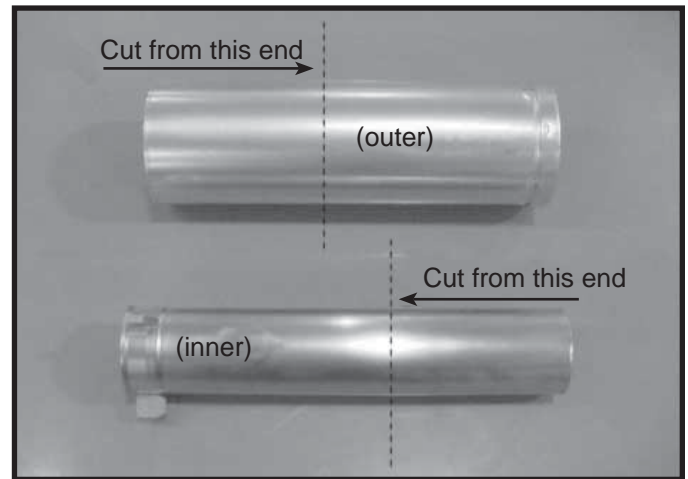

Figure 8.5

### Assembling Minimum Installations (MI) Sections

MI sections are non-unitized so that they can be cut to a certain length. Cut these sections to length from the non-expanded end (see Figure 8.5).

They can then be attached by first connecting the expanded end of the MI inner flue with the inner pipe from the adjacent pipe section and securing with three screws. The expanded portion of the MI inner flue must overlap completely with the unexpanded end of the adjacent pipe section.

The outer flue can then be inserted into the adjacent outer flue expanded end and attached to the next pipe section with three screws. The other end of the MI pipe section can then be attached by fitting another pipe section to it and snapping it together, as normal.

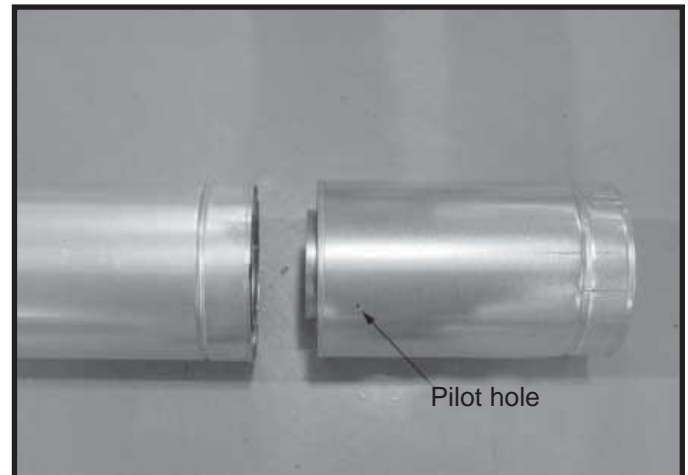

Figure 8.6 Slip Section Pilot Holes

### Assembling DVP-12A Slip Sections

The outer flue of the slip section should slide over the outer flue of the pipe section and into (inner flue) the last pipe section (see Figure 8.6).

Slide together to the desired length, making sure that a 1-1/2 inch outer flue overlap is maintained between the pipe section and slip section.

The pipe and slip section need to be secured by driving two screws through the overlapping portions of the outer flues using the pilot holes (see Figure 8.7).

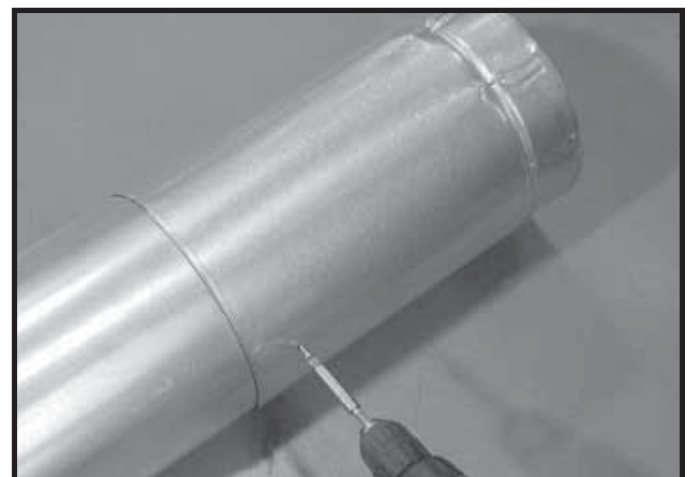

Figure 8.7 Screws into Slip Section

## Securing the Vent Sections

### Vertical Sections

Vertical sections of pipe must be supported every 8 feet after the 25 foot maximum unsupported rise. The vent support or plumber's strap (spaced 120° apart) may be used to do this (see Figure 8.8).

### Horizontal Sections

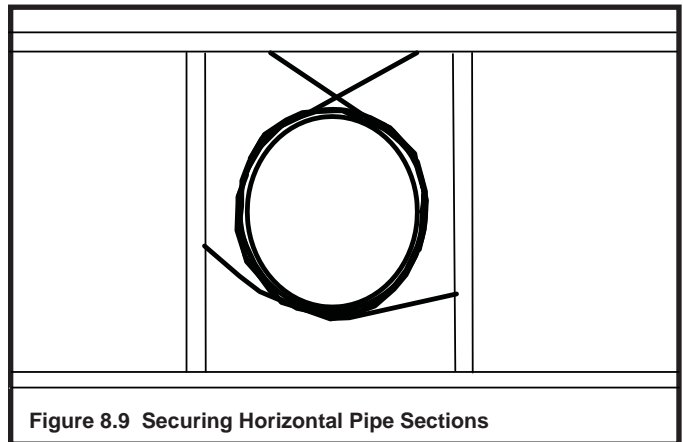
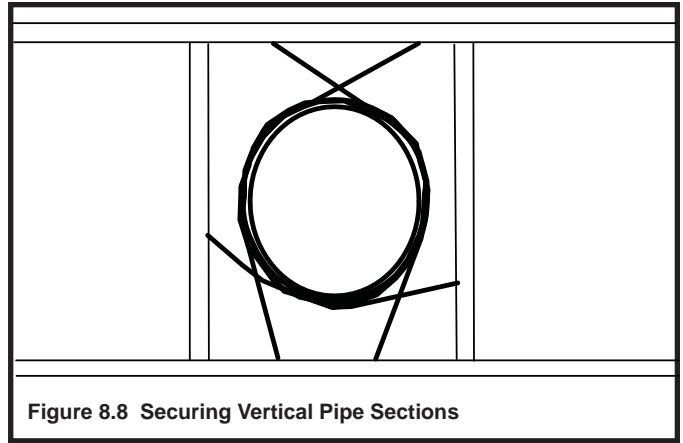

Horizontal sections of vent must be supported every 5 feet with a vent support or plumber's strap.

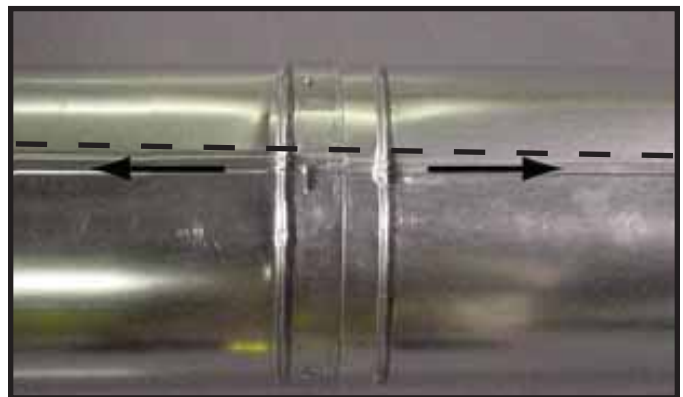
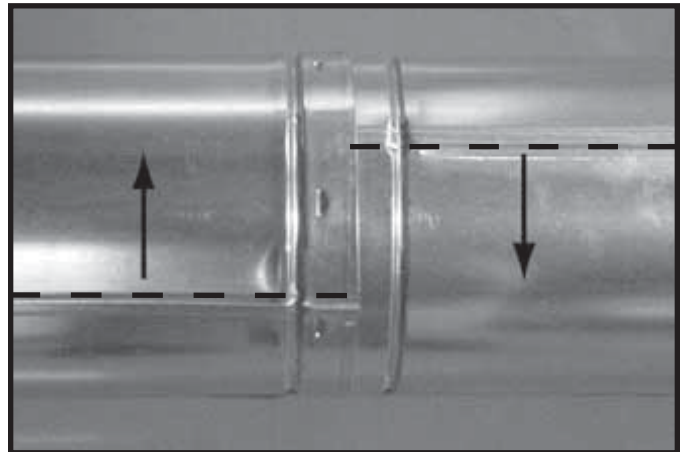

## B. Disassembly of Vent Sections

To disassemble any two pieces of pipe, rotate either section (see Figure 8.10), so that the seams on both pipe sections are aligned (see Figure 8.11). They can then be carefully pulled apart.



<b>⚠ WARNING</b>	
	Fire Risk. Explosion Risk. Combustion Fume Risk.
	Use vent run supports per installation instructions.
	Connect vent sections per installation instructions.
	<ul style="list-style-type: none"><li>• Maintain all clearances to combustibles.</li><li>• Do NOT allow vent to sag below connection point to appliance.</li></ul>
Improper support may allow vent to sag or separate.	



## C. Installing Heat Shield and Horizontal Termination Cap

### ⚠ WARNING



Fire Hazard

Impaired performance of appliance

- Telescoping flue section of termination cap MUST be used when connecting pipe section to termination cap.
- Maintain a 1-1/2 inch minimum overlap on telescoping flue section of termination cap.

### ⚠ WARNING



Fire Risk

Exhaust Fumes Risk

Impaired Performance of Appliance



- Overlap pipe slip sections at least 1-1/2 inches.
- Use pilot holes for screws.
- Screws must not exceed 1 inch long.
- Pipe may separate if not properly joined.

### Heat Shield Requirements for Horizontal Termination

For all horizontally vented appliances, a heat shield MUST be placed one inch above the top of the vent between the wall shield firestop and the base of the termination cap.

There are two sections of the heat shield. One section is factory-attached to the wall shield firestop. The other section is factory-attached to the cap. See Figure 8.12.

If the wall thickness does not allow the required 1-1/2 inch (38 mm) heat shield overlap when installed, an extended heat shield (DVP-HSM-B) must be used.

**Important Notice:** Heat shields may not be field constructed.

The extended heat shield (DVP-HSM-B) may need to be cut to length. You will attach the cut heat shield to the existing cap heat shield or wall shield firestop heat shield (refer to Figure 8.12) using the supplied screws. You MUST maintain a 1-1/2 in. (38 mm) overlap of the extended heat shield and the existing shields (both ends of the heat shield). The small leg on the extended heat shield should rest on the top of the vent (pipe section) to properly space it from the pipe section.

### Installing the Horizontal Termination Cap

Vent termination must not be recessed in the wall. Siding may be brought to the edge of the cap base.

Flash and seal as appropriate for siding material at outside edges of cap.

When installing a horizontal termination cap, follow the cap location guidelines as prescribed by current ANSI Z223.1 and CAN/CGA-B149 installation codes.

### ⚠ WARNING



Burn Risk

- Local codes may require installation of a cap shield to prevent anything or anyone from touching the hot cap.

**Note:** Where required, an exterior wall flashing is available. When penetrating a brick wall, a brick extension kit is available for framing the brick.

**NOTE:** Heat shields MUST overlap by a minimum of 1-1/2 in. (38 mm). The heat shield is designed to be used on a wall 4 in. to 7-1/4 in. (102 mm to 184 mm) thick. If wall thickness is less than 4 in. (102 mm) the existing heat shields must be field trimmed. If wall thickness is greater than 7-1/4 in. (184 mm) a DVP-HSM-B will be required.

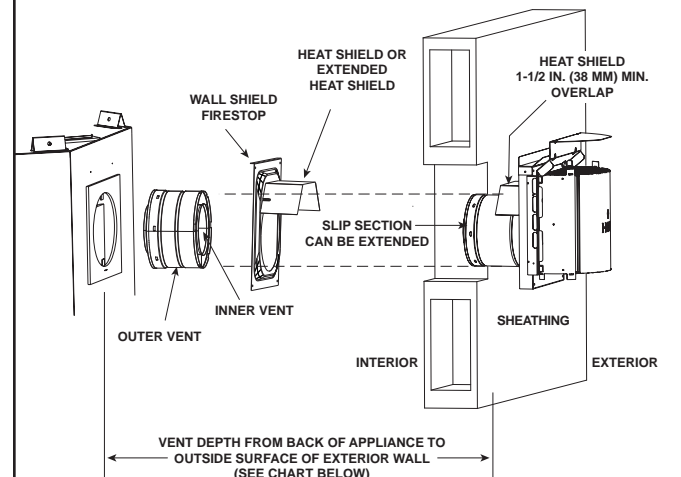

Figure 8.12 Venting through the Wall

### Termination Cap Specification Chart (depth without using additional pipe sections)

Escape-36DV	DVP-TRAPK1	DVP-TRAP1	DVP-TRAPK2	DVP-TRAP2
	Top Vent Depth	Rear Vent Depth	Top Vent Depth	Rear Vent Depth
	3-1/2 in. to 5-3/8 in.	N/A	6 in. to 10 in.	N/A

DVP-TRAP1 can adjust 1-1/2 in. (3-1/8 to 4-5/8)

DVP-TRAP2 can adjust 4 in. (5-3/8 to 9-3/8)



## D. Installing Roof Flashing and Vertical Termination Cap

To install roof flashing see Figure 8.13.

For installation of vertical termination cap see minimum vent heights for various pitched roofs (see Figure 8.13).

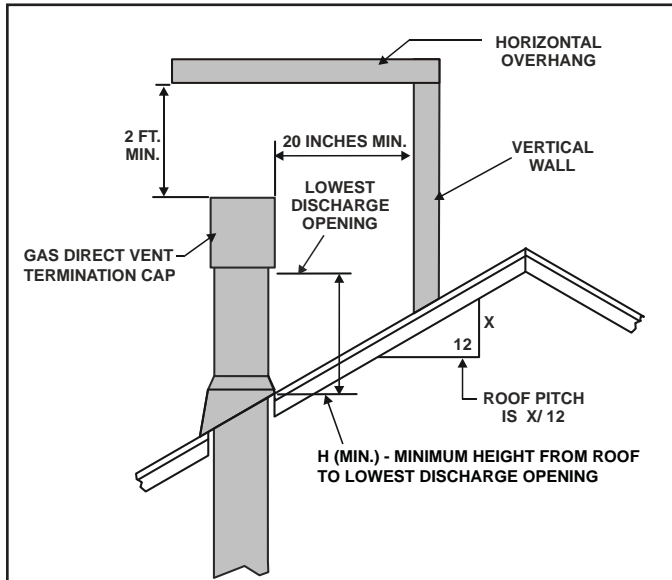

Roof Pitch	H (Min.) Ft.
Flat to 6/12.....	1.0*
Over 6/12 to 7/12.....	1.25*
Over 7/12 to 8/12.....	1.5*
Over 8/12 to 9/12.....	2.0*
Over 9/12 to 10/12.....	2.5
Over 10/12 to 11/12.....	3.25
Over 11/12 to 12/12.....	4.0
Over 12/12 to 14/12.....	5.0
Over 14/12 to 16/12.....	6.0
Over 16/12 to 18/12.....	7.0
Over 18/12 to 20/12.....	7.5
Over 20/12 to 21/12.....	8.0

\* 3 foot minimum in snow regions

Figure 8.13 Minimum height from roof to lowest discharge opening

**NOTICE:** Failure to properly caulk the roof flashing and pipe seams may permit entry of water.

- Caulk the gap between the roof flashing and the outside diameter of the pipe.
- Caulk the perimeter of the flashing where it contacts the roof surface. See Figure 8.14.
- Caulk the overlap seam of any exposed pipe sections that are located above the roof line.

To attach the vertical termination cap, slide the inner collar of the cap into the inner flue of the pipe section and place the outer collar of the cap over the outer flue of the pipe section.

Secure with three screws into the outer flue. Secure the cap by driving the three self-tapping screws (supplied) through the pilot holes in the outer collar of the cap into the outer flue of the pipe (see Figure 8.14).

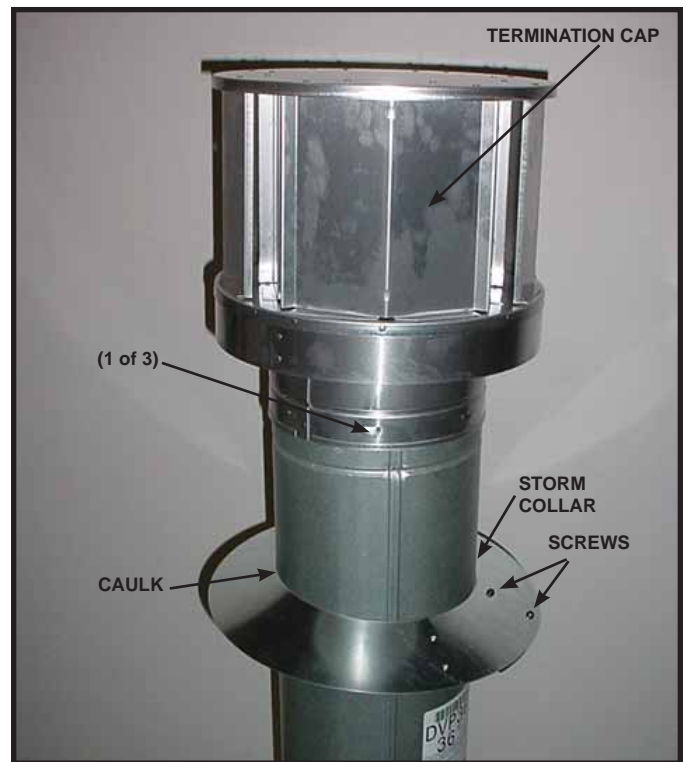

Figure 8.14

**⚠ WARNING**

Fire Risk.  
Explosion Risk.  
Inspect external vent cap regularly.

- Ensure no debris blocks cap.
- Combustible materials blocking cap may ignite.
- Restricted air flow affects burner operation.

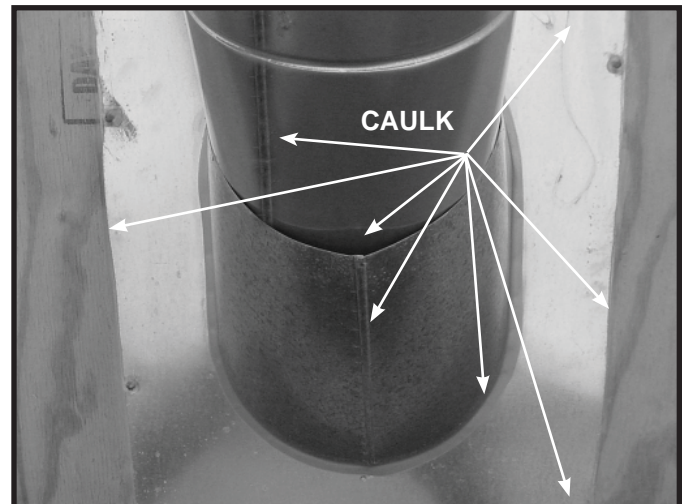

Figure 8.15

## Assembling and Installing Storm Collar

	<b>CAUTION</b>
	<p>Sharp Edges</p> <ul style="list-style-type: none"><li>• Wear protective gloves and safety glasses during installation.</li></ul> 

Connect both halves of the storm collar with two screws (see Figure 8.16).

Wrap the storm collar around the exposed pipe section and align brackets. Insert a bolt (provided) through the brackets and tighten nut to complete storm collar assembly (see Figure 8.17).

Slide the assembled storm collar down the pipe section until it rests on the roof flashing.

Caulk around the top of the storm collar (see Figure 8.14).



Figure 8.17 Assembling the Storm Collar Around the Pipe

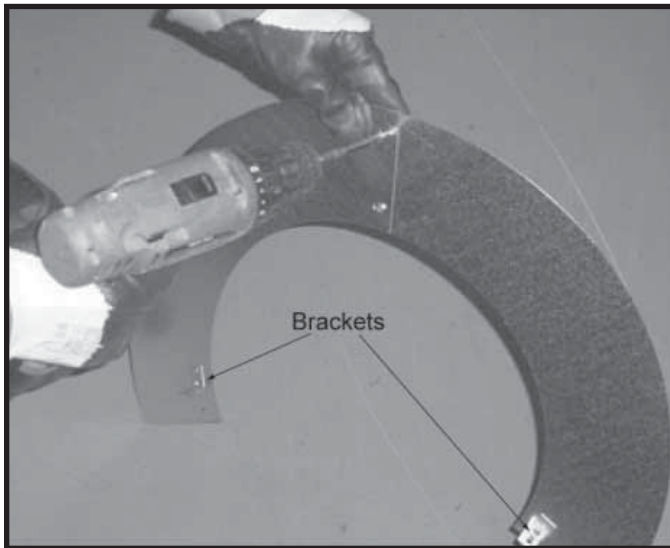

Figure 8.16 Assembling the Storm Collar

# 9 Gas Information

## A. Fuel Conversions

Before making gas connections ensure that appliance being installed is compatible with the available gas type.

Any natural or propane gas conversions necessary to meet the appliance and locality needs must be made by a qualified technician using Hearth & Home Technologies specified and approved parts.

## B. Gas Pressures

Proper input pressures are required for optimum appliance performance. Gas line sizing requirements need to be made following NFPA54.

**⚠ WARNING**



Fire Risk.  
Explosion Hazard.  
High pressure will damage valve.

- Disconnect gas supply piping BEFORE pressure testing gas line at test pressures above 1/2 psig.
- Close the manual shutoff valve BEFORE pressure testing gas line at test pressures equal to or less than 1/2 psig.

**⚠ WARNING**



Verify inlet pressures.

- High pressure may cause overfire condition.
- Low pressure may cause explosion.
- Verify minimum pressures when other household gas appliances are operating.

Install regulator upstream of valve if line pressure is greater than 1/2 psig.

Pressure requirements for appliance are shown in the table below. Minimum pressures must be met when other household gas appliances are operating.

Pressure	Natural Gas	Propane
Minimum inlet pressure	5.0 inches w.c.	11.0 inches w.c.
Maximum inlet gas pressure	14.0 inches w.c.	14.0 inches w.c.
Manifold pressure	3.5 inches w.c.	10.0 inches w.c.

## C. Gas Connection

**Note:** Have the gas supply line installed in accordance with local building codes, if any. If not, follow ANSI 223.1. Installation should be done by a qualified installer approved and/or licensed as required by the locality. (In the Commonwealth of Massachusetts installation must be performed by a licensed plumber or gas fitter).

**Note:** A listed (and Commonwealth of Massachusetts approved) 1/2 inch (13 mm) T-handle manual shut-off valve and flexible gas connector are connected to the 1/2 inch (13 mm) control valve inlet.

- **If substituting for these components, please consult local codes for compliance.**

Refer to **Reference Section 16** for location of gas line access in appliance.

**Note:** Gas line may be run from either side of the appliance provided the hole in the outer wrap does NOT exceed 2-1/2 inches in diameter and does not penetrate the firebox.

**⚠ WARNING**





Gas Leak Risk



- Support control when attaching pipe to prevent bending gas line.

**Note:** The gap between supply piping and gas access hole may be caulked with high temperature caulk or stuffed with non-combustible, unfaced insulation to prevent cold air infiltration.

- Ensure that gas line does not come in contact with outer wrap of appliance. Follow local codes.
- Incoming gas line should be piped into the valve compartment and connected to the 1/2 inch connection on the manual shutoff valve.

<b>⚠ WARNING</b>	
	<p>Fire or Explosion Hazard</p> <ul style="list-style-type: none"> <li>• Gas buildup during line purge may ignite.</li> <li>• Purge should be performed by qualified technician.</li> <li>• Ensure adequate ventilation.</li> <li>• Ensure there are no ignition sources such as sparks or open flames.</li> </ul>
	

- A small amount of air will be in the gas supply lines. When first lighting appliance it will take a short time for air to purge from lines. When purging is complete the appliance will light and operate normally.

<b>⚠ WARNING</b>	
	<p><b>CHECK FOR GAS LEAKS</b></p> <p>Explosion Risk Fire Risk Asphyxiation Risk</p> <ul style="list-style-type: none"> <li>• Check all fittings and connections.</li> <li>• Do not use open flame.</li> <li>• After the gas line installation is complete, all connections must be tightened and checked for leaks with a commercially-available, non-corrosive leak check solution. Be sure to rinse off all leak check solution following testing.</li> </ul>
	<p>Fittings and connections may have loosened during shipping and handling.</p>

<b>⚠ WARNING</b>	
	<p>Fire hazard.</p> <p>Do NOT change the valve settings.</p> <ul style="list-style-type: none"> <li>• This valve has been preset at the factory.</li> <li>• Changing valve settings may result in fire hazard or bodily injury.</li> </ul>

<p><b>HIGH ALTITUDE INSTALLATIONS</b></p> <p>U.L. Listed gas appliances are tested and approved without requiring changes for elevations from 0 to 2000 feet in the U.S.A. and Canada.</p> <p>When installing this appliance at an elevation above 2000 feet, it may be necessary to decrease the input rating by changing the existing burner orifice to a smaller size. Input rate should be reduced by 4% for each 1000 feet above a 2000 foot elevation in the U.S.A., or 10% for elevations between 2000 and 4500 feet in Canada. If the heating value of the gas has been reduced, these rules do not apply. To identify the proper orifice size, check with the local gas utility.</p> <p>If installing this appliance at an elevation above 4500 feet (in Canada), check with local authorities.</p>
--

# 10 Electrical Information



## A. Recommendation for Wire

This appliance requires 110-120 VAC be wired to the junction box for proper operation of the appliance (Intellifire ignition).

**Note:** This appliance must be electrically wired and grounded in accordance with local codes or, in the absence of local codes, with **National Electric Code ANSI/NFPA 70-latest edition** or the **Canadian Electric Code, CSA C221.1**.

- A 110-120 VAC circuit for this product must be protected with ground-fault circuit-interrupter protection, in compliance with the applicable electrical codes, when it is installed in locations such as in bathrooms or near sinks.

## B. Connecting to the Appliance

	<b>⚠ WARNING</b>
	Wire 110V to electrical junction box. Do NOT wire 110V to valve. Do NOT wire 110V to wall switch. <ul style="list-style-type: none"><li>• Incorrect wiring will damage millivolt valves.</li><li>• Incorrect wiring will override IPI safety lockout and may cause explosion.</li></ul>

### Wall Switch

This appliance comes standard with a multi-function wall switch installed in the unit. A bag containing the wall switch, cover plate and flame control solenoid is located in the manual bag assembly on the right side of unit. Follow the “Determine Location” and “Wiring the Wall Switch” sections of the WSK-MLT instructions. Install the flame control solenoid by following Steps 5 - 11 in the “Installing the Control Box” section of the WSK-MLT instructions. You must also carefully follow the “Setting Flame Height/Manifold Pressure” section of the included instructions to properly set the valve pressure. Operating instructions are also included in the WSK-MLT instructions.

- Use the wire provided with this product to connect the wall switch to the receiver, as outlined in the WSK-MLT instructions.
- Keep wire lengths short as possible by removing any excess wire length.
- Low voltage and 110 VAC voltage cannot be shared within the same wall box.

## C. Intellifire Ignition System Wiring

This appliance requires a 110 VAC supply to the appliance junction box for operation. A wiring diagram is shown in Figure 10.1.

This appliance is equipped with an Intellifire control valve which operates on a 3 volt system.

This appliance is supplied with a battery pack and a 3 volt AC transformer, which requires the installation of the supplied junction box. It is highly recommended that the junction box be installed at this time to avoid reconstruction.

The battery pack requires two D cell batteries (not included). Batteries cannot be placed in the battery pack while using the 3 volt transformer. Batteries shouldn't be placed into the holder until needed. The higher temperatures will shorten their life.

<b>CAUTION</b>
Remove refractory panels and mesh when operating appliance using the battery pack or damage to components may occur. Use battery pack to operate appliance only in a power failure situation.

<b>CAUTION</b>
Battery polarity must be correct or module damage will occur.

### Optional Accessories Requirements

Wiring for optional accessories should be done now to avoid reconstruction. Heat-Zone kits are approved with this appliance as heat management accessories.

<b>CAUTION</b>
Label all wires prior to disconnection when servicing controls. Wiring errors can cause improper and dangerous operation. Verify proper operation after servicing.

	<b>⚠ WARNING</b>
	Shock hazard. <ul style="list-style-type: none"><li>• Replace damaged wire with type 105° C rated wire.</li><li>• Wire must have high temperature insulation.</li></ul>

WIRES WITH LABEL "FOR USE WITH REMOTE OR WALL SWITCH ONLY" (LOCATED UNDER FIREPLACE)

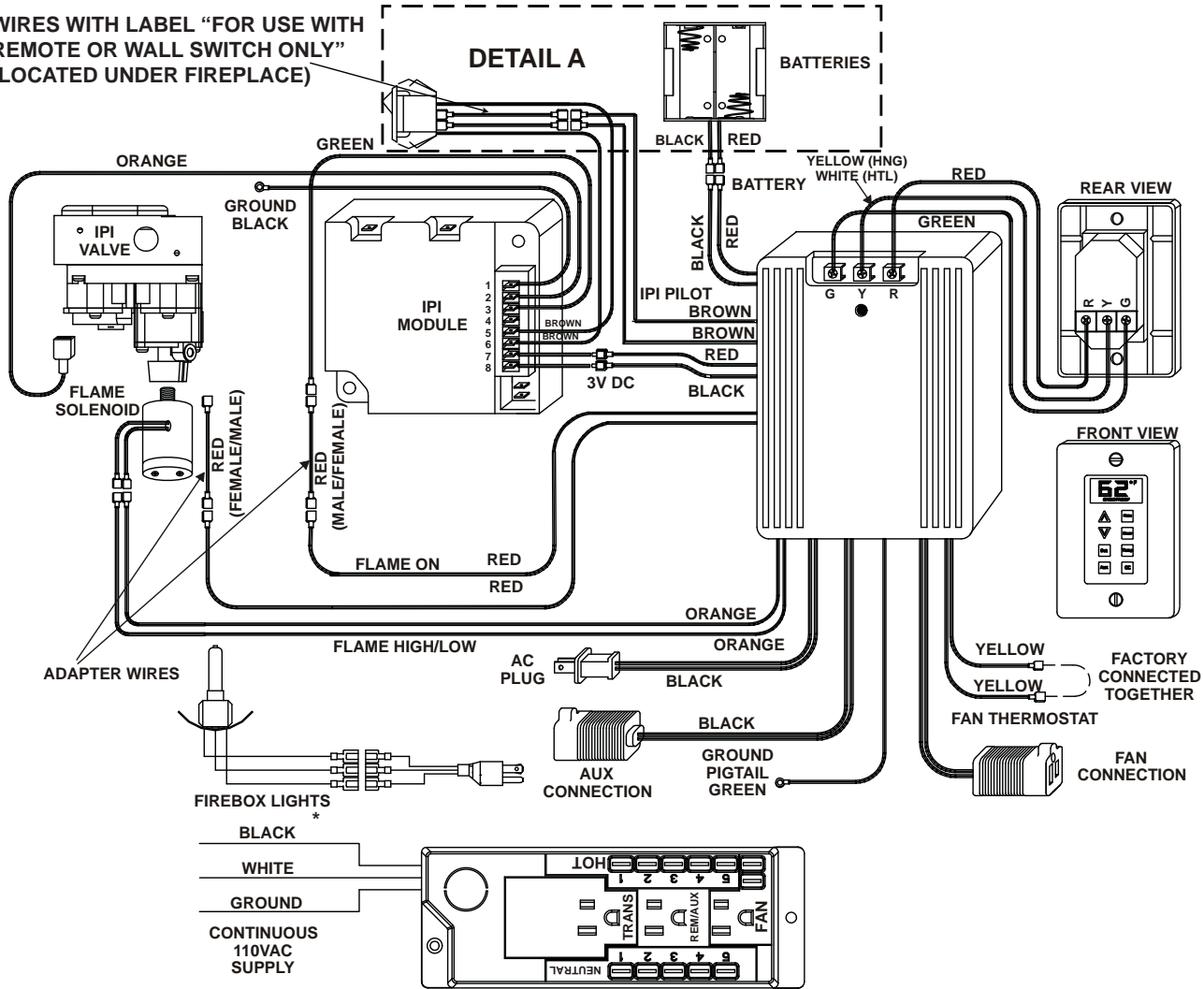

**NOTE: BATTERY PACK AND SWITCH ARE LOCATED IN THE MANUAL BAG. THE BATTERY PACK IS TO BE USED ONLY IN THE CASE OF A POWER OUTAGE.**

**NOTE: APPLIANCE WILL NOT OPERATE UNLESS PROPERLY GROUNDED. \*MUST ORDER PLUG-ADP SEPARATELY IF USING THE HEAT-ZONE.**

**NOTE: IGNITION MODULE, VALVE, PILOT AND WALL SWITCH OPERATE ON 3 VOLTS.**

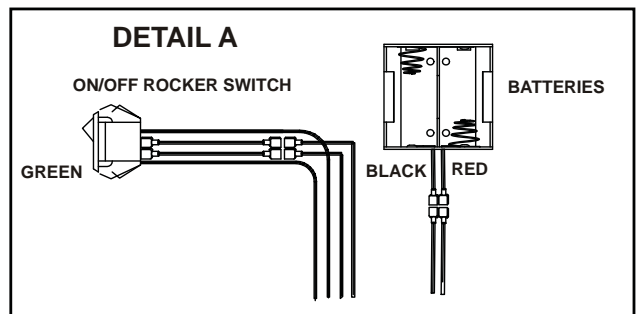

Figure 10.1 Intellifire Pilot Ignition (IPI) Wiring Diagram

\*Note: Appliance will not operate unless properly grounded.



## D. Junction Box Installation

If the box is being wired from the **OUTSIDE** of the appliance:

- Remove the cover plate located on the outer shell - left side. See Figure 10.3.
- Install the supplied Romex™ connector in the cover plate.
- Feed the necessary length of wire through the connector.
- Make all necessary wire connections and reattach the cover plate to the outer shell.

If the box is being wired from the **INSIDE** of the appliance:

- Remove the screw attaching the junction box/receptacle to the outer shell, rotate the junction box inward to disengage it from the outer shell (see Figure 10.3).
- Pull the electrical wires from outside the appliance through this opening into the valve compartment.

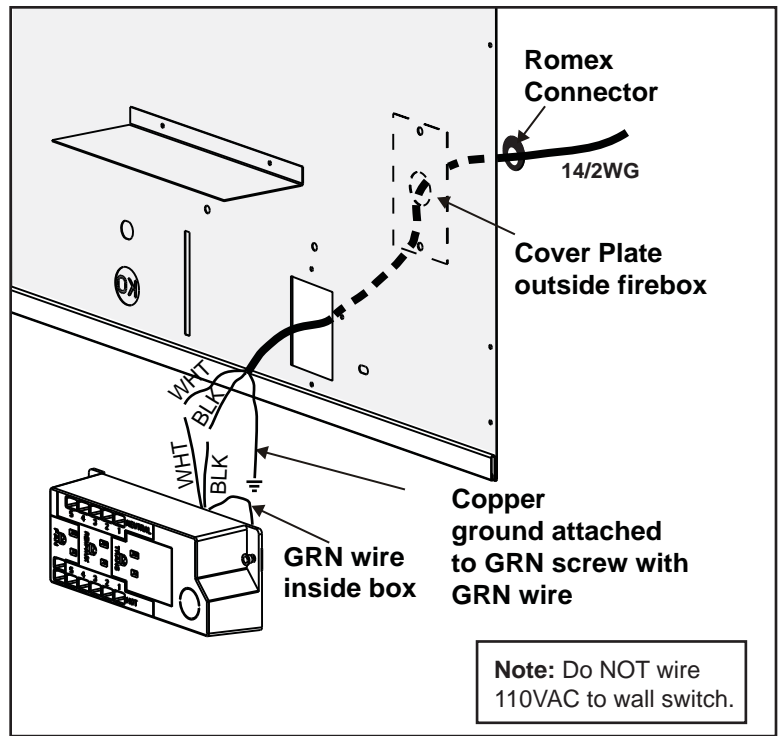

Figure 10.3 Junction Box Detail

- Feed the necessary length of wire through the connector.
- Make all necessary wire connections to the junction box/receptacle and reassemble the junction box/receptacle to the outer shell.



# 11 Finishing

## A. Mantel Projections

Figure 11.1 shows the minimum vertical and corresponding maximum horizontal dimensions of appliance mantels or other combustible projections above the opening edge of the appliance.

Non-combustible materials must be used in the 7-1/2 inch zone on each side and in the 10 inch zone above the appliance opening (see Figure 11.3).

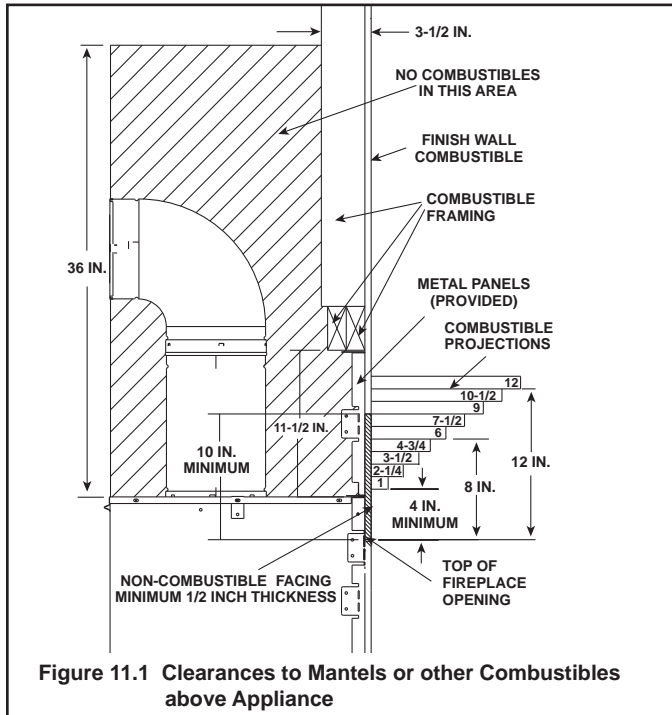

Figure 11.1 Clearances to Mantels or other Combustibles above Appliance

Height Above Opening	Horizontal Mantel Distance
4 in.	1 in.
5 in.	2-1/4 in.
6 in.	3-1/2 in.
7 in.	4-3/4 in.
8 in.	6 in.
9 in.	7-1/2 in.
10 in.	9 in.
11 in.	10-1/2 in.
12 in.	12 in.

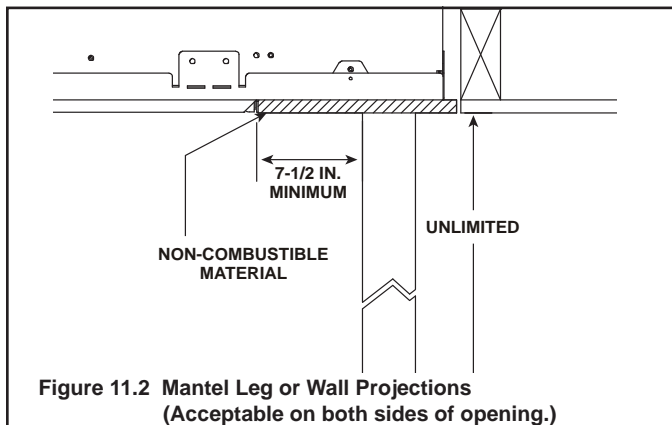

Figure 11.2 Mantel Leg or Wall Projections (Acceptable on both sides of opening.)

## B. Facing Material

**⚠ WARNING**

**Fire Risk.**

- Facing and/or finishing material must never overhang into the glass opening.
- Finishing materials must not interfere with:
  - Operation of louvers or doors.
  - Access for service.

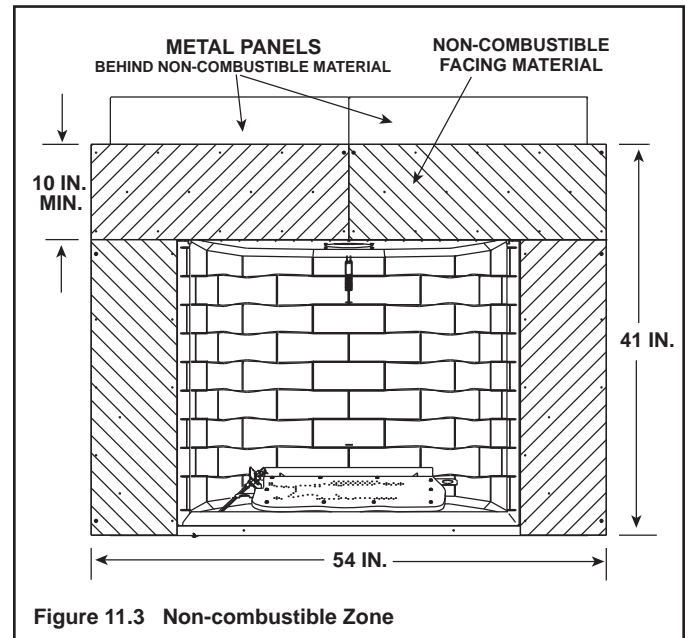

Figure 11.3 Non-combustible Zone

**⚠ WARNING**

**Risk of Fire**

- Non-combustible clearances **MUST** be maintained.
- Sheetrock, wood or other combustibles must **NOT** be used as sheathing or facing in the non-combustible zone.
- See **Section 11** for proper clearances.
- See **Section 1** for combustible/non-combustible definitions.

**⚠ WARNING**

**Fire Risk.**

Hearth extension required to protect combustible floors in front of appliance.

- An 12 inch minimum hearth extension must be constructed of non-combustible material.



## WARNING

Fire Risk.  
Finish all edges and fronts to clearances and specifications listed in manual.

- Finishing material must NEVER pass the 1/2 inch metal edge around opening and overhang into glass opening.
- Only non-combustible material (using 300°F. Minimum adhesive, if needed) can be applied as facing to fireplace surround in first 4 inches from opening sides and 6 inches above the opening.
- Install combustible materials only up to specified clearances on top, front and side edges.
- Seal joints between the finished wall and appliance top and sides using only a 300°F minimum sealant.

## Finishing Requirements

**Note:** Optional firescreen sits out 1-1/2 inches from the face of the appliance. When using thin finishing material, you may want to use thicker non-combustible backer board to bring the finishing material flush with the firescreen. This is not required.

- Use the two metal panels shipped with fireplace.
- Unscrew the four screws holding two panels together.
- Slide the two tapered tabs on bottom of each panel into slots of top surround.
- Secure panels with sheetmetal screws previously removed from panels.

The metal panels will cover the width of appliance and height of appliance to header board.

The entire face of the appliance is covered with non-combustible finishing material, such as brick, stone or tile (see Figures 11.3 and 11.4).

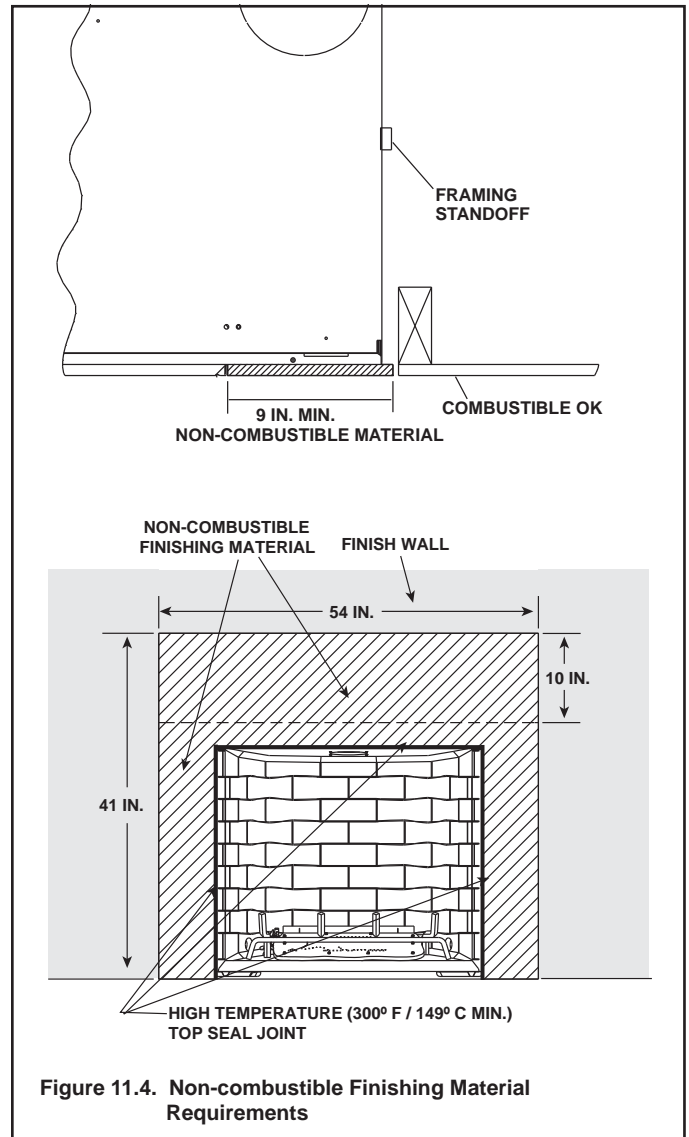

Figure 11.4. Non-combustible Finishing Material Requirements

The finishing material must NEVER pass the 1/2 inch metal edge around the opening and overhang into the glass opening.



## WARNING

Fire Risk.  
Finishing materials must not interfere with:

- Operation of louvers or doors.
- Access for service.

# 12 Appliance Setup

## A. Remove Shipping Materials

Remove shipping materials from inside or underneath the firebox.

## B. Clean the Appliance

Clean/vacuum any sawdust that may have accumulated inside the firebox or underneath in the control cavity.

## C. Accessories

Install approved accessories per instructions included with accessories. See Service Parts List for appropriate accessories. Refer to **Section 16**.



### ⚠ WARNING

Shock or fire risk.  
Use **ONLY** optional accessories approved for this appliance.



- Using non-listed accessories voids warranty.
- Using non-listed accessories may result in a safety hazard.
- Only Hearth & Home Technologies approved accessories may be used safely.

## D. Installing the Optional Heat-Zone-Gas Kit

1. Remove the knockout from the top of the appliance and discard it (see Figure 12.1).
2. Center the duct collar around the exposed hole and attach it to the appliance with 3 screws. **Note:** Do this **BEFORE** final positioning of the appliance.
3. Determine the location for the air register/fan housing assembly.

Reference the Heat-Zone-Gas kit instructions for the remaining installations steps.

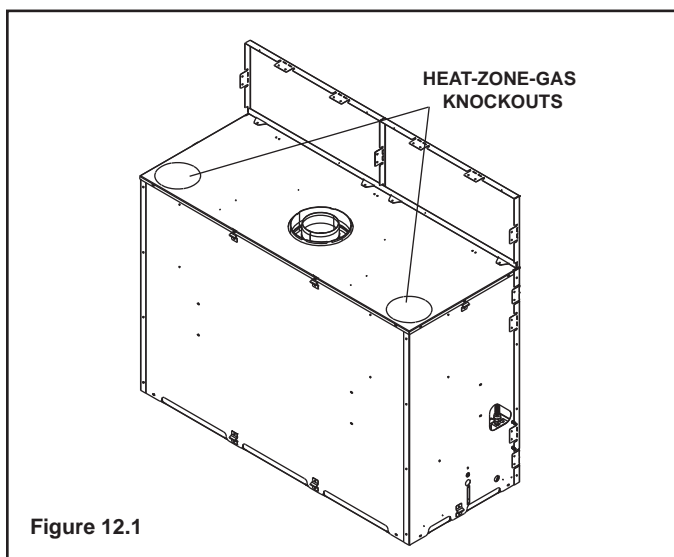



Figure 12.1

## E. Ember Placement

### ⚠ WARNING



Explosion Risk.

- Follow ember placement instructions in manual.
- Do **NOT** place embers directly over burner ports.
- Replace ember material annually.

Improperly placed embers interferes with proper burner operation.

### Placing the Ember Material

Ember material is shipped with this gas appliance. To place the ember material:

- Remove the ash lip (see Figure 12.2) that is located in front of the glass.

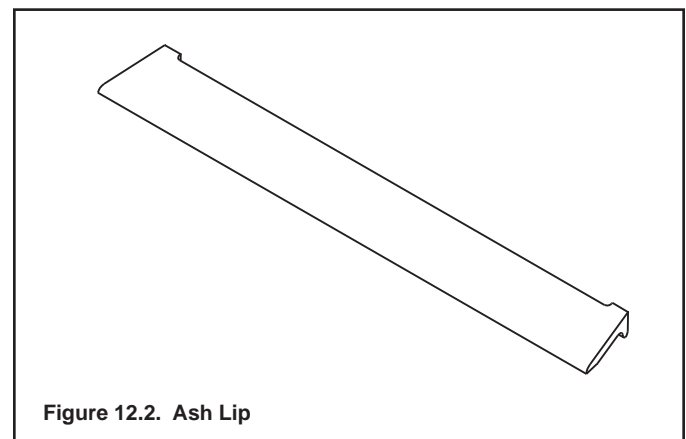

Figure 12.2. Ash Lip

- Remove the side panels located in front of the glass.
- Remove the pull mesh firescreen by unhooking from the appliance.
- Pull and release the four glass latches (2 per side) located on the sides of the glass frame.
- Grasping the upper lip with one hand and the lower lip with the other, pull the bottom of the glass out first. Guide the bottom while letting the top drop down under the top of the opening.
- There are two types of ember shipped with the unit. Embers for the burner surface and Mystic Embers for the floor of the unit.
- Do **NOT** place embers between log #3 and log #4. They may disrupt the flames and are not visible.
- Place Mystic Embers on the floor of unit. Use Mystic Embers to hide the pilot wires on left side of the burner.
- Save the remaining ember materials for use during appliance servicing.
- Replace glass firescreen and door front trim on the unit.

**CAUTION:** Logs are fragile! Carefully remove the logs from the packaging.

→ **NOTE:** If logs rub against one another during positioning, the white inner material may become visible. Touch-up paint may be applied to the white areas using a small brush or swab. **DO NOT** spray paint directly on surface of the logs. Reference service parts list for log touch-up paint.



**Step 1.**

Place the grate onto the burner. The back of the right tine drops into the hole on the right rear of the burner. The shorter left tine is pushed back into the half-hole on the left side of the burner. Be sure to push the grate all the way down to the floor and firmly back into its holder.



**LOG #1 (SRV2012-081) (TWO):**

There are quantity two (2) of log #1. Place one of the logs on the floor of the fireplace on the left side of the burner between the burner and the left tine of the grate. Place the second log on the right side of the burner between the burner and the right tine of the grate. The second log can be slightly resting on the edge of the burner.





## LOG #2

### (SRV2012-082):

Place log #2 on the left side of the burner with the black end of the log on top of the pilot bracket. The log will rest touching the side of the fire-box. The purpose of this log is to help disguise the pilot. Do NOT have the log touching the pilot or pilot operation may be affected.



## LOG #3

### (SRV2012-083):

Place Log #3 onto the back of the burner. The left end of the log sits on the bent up tab and top of the burner surface. The back of the log is pushed up against the back metal wall of the burner on the left side and the bent up tab on the right side. The left end of the log is flush with the left edge of the metal wall.

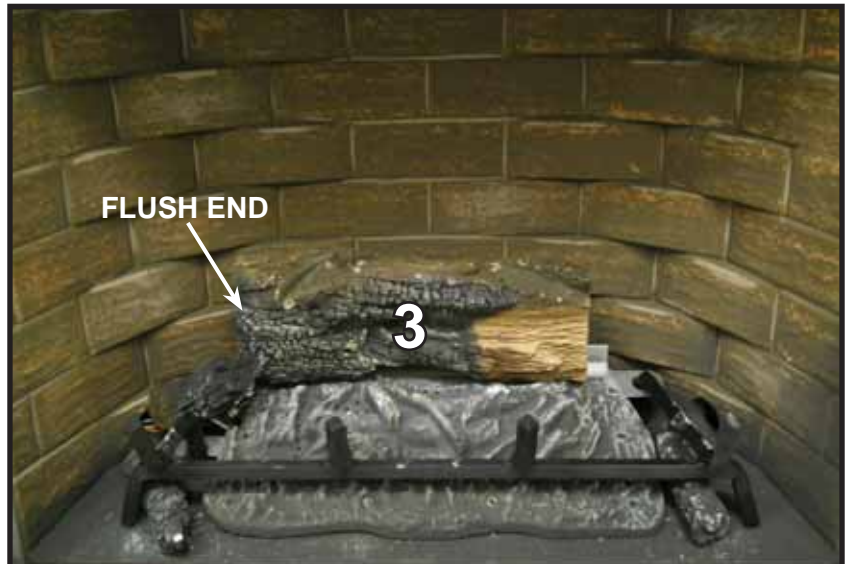

## LOG #4

### (SRV2012-084):

Place log #4 on top of the burner in front of log 3. The triangle shaped groove in the bottom fits onto the right tine of the grate. The left end of the log will fit the contour of the burner between the ports. Do NOT cover the burner ports.



**LOG #5**

**(SRV2012-085):**

Place log #5 in front of log #4. The groove in the bottom end of the log fits into the right vertical tine of the grate. The back of the log rests in the groove on top of log #3.

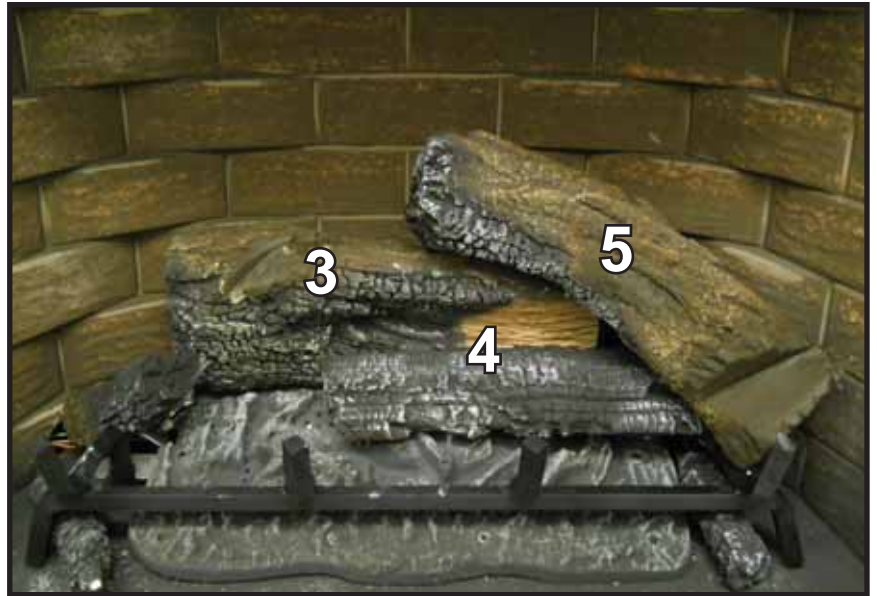

**LOG #6**

**(SRV2012-086):**

Place log #6 on the left side of the grate with the groove on the end of the log fitting into the vertical left tine of the grate. The burned end of the log rests in the groove on the left side of log #3.



**LOG #7**

**(SRV2012-087):**

Place log #7 on top of log #6. The groove in the front side of the log fits into the second vertical tine from the left of the grate. The center of the log rests in the flat spot on log #6.





## LOG #8

### (SRV2012-088):

Place Log #8 on top of Log #5. The flat bottom of Log #8 sits on the large flat area of Log #5. The burned end of Log #8 rests on the second vertical tine from the right of the grate. The tine fits on the burned out groove on the left end of the log.

### Final Step:

Place MYSTIC EMBERS generously around on the floor of the fireplace. Some can be spread out on the burner surface to blend the transition. Place embers around the pilot wires to disguise the wires from view.

**Save the log instructions for future use.**



2012-945B



## G. Glass Assembly

### ⚠ WARNING



Handle glass doors with care.

- Inspect the gasket to ensure it is undamaged.
- Inspect the glass for cracks, chips or scratches.
- Do NOT strike, slam or scratch glass.
- Do NOT operate appliance with glass door removed, cracked, broken or scratched.
- Replace glass door assembly as a complete appliance.

### Removing Glass Assembly

- Remove the ash lip that is located in front of the glass.
- Remove the side panels located in front of the glass.
- Remove the pull mesh firescreen by unhooking from the fireplace.
- Pull and release the six glass latches (3 per side) located on the sides of the glass frame.
- Grasping the upper lip with one hand and the lower lip with the other, pull the bottom of the glass out first. Guide the bottom while letting the top drop down under the top of the opening (see Figure 12.13).

### Replacing Glass Assembly

Replace the glass door on the appliance. Pull out and latch the six glass assembly latches into the groove on the glass frame.

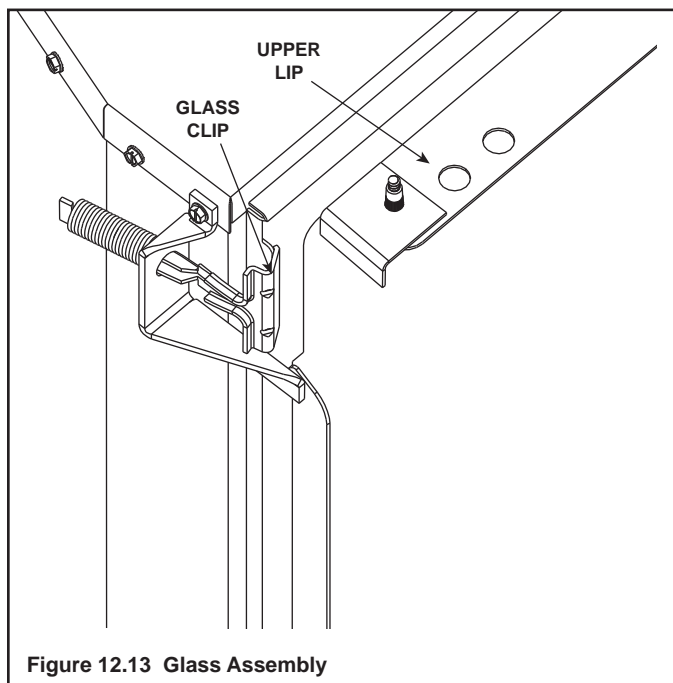

Figure 12.13 Glass Assembly

## H. Grilles and Trim

Install optional marble and brass trim surround kits as desired. Marble, brass, brick, tile, or other noncombustible materials can be used to cover up the gap between the sheet rock and the appliance.

Do not obstruct or modify the air inlet/outlet grilles. When overlapping on both sides, leave enough space so that the bottom grille can be lowered and the trim door removed.

## I. Air Shutter Setting

This appliance has an adjustable air shutter (which controls the primary air) factory set for the minimum vertical vent run. If your installation has more than the minimum required vertical vent length, adjustment of the air shutter may be necessary to obtain optimal flame appearance. **This should be adjusted by a qualified installer at the time of installation.**

### Shutter Settings

	NG	LP
Burner	1/4 in.	Full Open

# 13 Operating Instructions

## A. Before Lighting Appliance

Before lighting this appliance determine if it has a Standing Pilot or Intellifire ignition system by opening the control access panel to view wiring system and gas valve. If this appliance has a red or black ignitor button (see Figure 10.1) this appliance has a Standing Pilot ignition system. If there is no red or black ignitor button, this appliance has an Intellifire ignition system.

### CAUTION

If installing Intellifire ignition battery backup:

- Do not install batteries if the backup mode may not be used for extended time.
- Batteries may leak.
- Install batteries only when needed for power outage.

### Before operating this appliance have a qualified technician:

- Remove all shipping materials from inside and/or underneath the firebox.
- Review proper placement of logs, rockwool, lava rock, and vermiculite.
- Check the wiring.
- Check the air shutter adjustment.
- Ensure that there are no gas leaks.
- Ensure that the glass is sealed and in the proper position.
- Ensure that the flow of combustion and ventilation air is not obstructed (front grilles and vent caps).



### WARNING

Glass door must be in place when appliance is operating.

Risk of:

- Combustion Fumes
- Fire

Do NOT operate appliance with glass door removed.

- Open viewing glass for servicing only.



- Glass door MUST be in place and sealed before operating appliance.
- Only use glass door certified for use with appliance.
- Glass replacement should be done by qualified technician.

### WARNING



#### HOT SURFACES!

Glass and other surfaces are hot during operation AND cool down.

#### Hot glass will cause burns.

- Do not touch glass until it is cooled
- NEVER allow children to touch glass
- Keep children away
- CAREFULLY SUPERVISE children in same room as fireplace.
- Alert children and adults to hazards of high temperatures.

#### High temperatures may ignite clothing or other flammable materials.

- Keep clothing, furniture, draperies and other flammable materials away.

*This appliance has been supplied with an integral barrier to prevent direct contact with the fixed glass panel. Do NOT operate the appliance with the barrier removed.*

Contact your dealer or Hearth & Home Technologies if the barrier is not present or help is needed to properly install one.

### WARNING

Improper installation, adjustment, alteration, service or maintenance can cause injury or property damage. Refer to the owner's information manual provided with this appliance. For assistance or additional information consult a qualified installer, service agency or the gas supplier.

### WARNING

Do NOT use this appliance if any part has been under water. Immediately call a qualified service technician to inspect the appliance and to replace any part of the control system and any gas control which has been under water.

## B. Lighting Appliance

### IPI Ignition

#### FOR YOUR SAFETY READ BEFORE LIGHTING

**WARNING:** If you do not follow these instructions exactly, a fire or explosion may result causing property damage, personal injury or loss of life.

- A.** This appliance is equipped with an intermittent pilot ignition (IPI) device which automatically lights the burner. **DO NOT** try to light the burner by hand.
- Immediately call your gas supplier from a neighbor's phone. Follow the gas supplier's instructions.
  - If you cannot reach your gas supplier, call the fire department.

- B. BEFORE LIGHTING,** smell all around the appliance area for gas. Be sure to smell next to the floor because some gas is heavier than air and will settle on the floor.
- C. DO NOT** use this appliance if any part has been under water. Immediately call a qualified service technician to inspect the appliance and to replace any part of the control system and any gas control which has been under water.

#### WHAT TO DO IF YOU SMELL GAS

- **DO NOT** try to light any appliance.
- **DO NOT** touch any electric switch; do not use any phone in your building.

#### WARNING:

**DO NOT CONNECT LINE VOLTAGE (110/120 VAC OR 220/240 VAC) TO THE CONTROL VALVE.**

Improper installation, adjustment, alteration, service or maintenance can cause injury or property damage. Refer to the owner's information manual provided with this appliance.

This appliance needs fresh air for safe operation and must be installed so there are provisions for adequate combustion and ventilation air.

If not installed, operated, and maintained in accordance with the manufacturer's instructions, this product could expose you to substances in fuel or fuel combustion which are known to the State of California to cause cancer, birth defects, or other reproductive harm.

Keep burner and control compartment clean. See installation and operating instructions accompanying appliance.

For additional information on operating your  
Hearth & Home Technologies fireplace, please refer to [www.fireplaces.com](http://www.fireplaces.com).

#### CAUTION:

Hot while in operation. **DO NOT** touch. Keep children, clothing, furniture, gasoline and other liquids having flammable vapors away.

**DO NOT** operate the appliance with fixed glass assembly removed, cracked or broken. Replacement of the fixed glass assembly should be done by a licensed or qualified service person.

#### NOT FOR USE WITH SOLID FUEL

For use with natural gas and propane. A conversion kit, as supplied by the manufacturer, shall be used to convert this appliance to the alternate fuel.

**Also Certified for Installation in a Bedroom or a Bedsitting Room.**

For assistance or additional information, consult a qualified installer, service agency or the gas supplier.

#### LIGHTING INSTRUCTIONS (IPI)

1. This appliance is equipped with an ignition device which automatically lights the burner. **DO NOT** try to light the burner by hand.

**GAS  
VALVE**

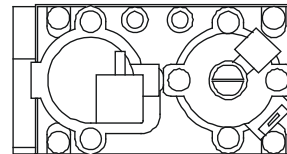

2. Wait five (5) minutes to clear out any gas. Then smell for gas, including near the floor. If you smell gas, **STOP!** Follow "B" in the Safety Information located on the left side of this label. If you do not smell gas, go to next step.

3. To light the burner:  
Equipped with wall switch: Turn ON/OFF switch to ON.

Equipped with remote or wall control: Press ON or FLAME button.

Equipped with thermostat: Set temperature to desired setting.

4. If the appliance does not light after three tries, call your service technician or gas supplier.

#### TO TURN OFF GAS TO APPLIANCE

1. Equipped with wall switch: Turn ON/OFF switch to OFF.

Equipped with remote or wall control: Press OFF button.

Equipped with thermostat: Set temperature to lowest setting.

2. Service technician should turn off electric power to the control when performing service.

593-913G

Final inspection by \_\_\_\_\_



## C. After Appliance is Lit

### Initial Break-in Procedure

When you light the appliance, you may notice that it produces heat which does have an associated odor or smell. If you feel this odor is excessive it may require the initial three to four hour continuous burn on high followed by a second burn up to 12 hours to fully drive off any odor from paint and lubricants used in the manufacturing process. Condensation of the glass is normal.



**Note:** The appliance should be run three to four hours on the initial start-up. Turn it off and let it cool completely. Remove and clean the glass. Replace the glass and run the appliance for an additional 12 hours. This will help to cure the products used in the paint and logs.

During this break-in period it is recommended that some windows in the house be opened for air circulation. This will help avoid setting off smoke detectors, and help eliminate any odors associated with the appliance's initial burning.

 <b>WARNING</b>	
	<p>Fire Risk. High Temperatures. Keep combustible household items away from appliance. Do NOT obstruct combustion and ventilation air.</p> <ul style="list-style-type: none"> <li>• Do NOT place combustible items on top of or in front of appliance.</li> <li>• Keep furniture, draperies away from appliance.</li> </ul>

<b>CAUTION</b>
<ul style="list-style-type: none"> <li>• Prevent accidental appliance operation when not attended.</li> <li>• Unplug or remove batteries from remote control if absent or if appliance will not be used for an extended period of time.</li> <li>• Property damage possible from elevated temperatures.</li> </ul>

<b>CAUTION</b>
<p>Smoke and odors released during initial operation.</p> <ul style="list-style-type: none"> <li>• Open windows for air circulation.</li> <li>• Leave room during initial operation.</li> <li>• Smoke may set off smoke detectors.</li> </ul> <p>Smoke and odors may be irritating to sensitive individuals.</p>

 <b>WARNING</b>	
	<p>Fire Hazard. Keep combustible materials, gasoline and other flammable vapors and liquids clear of appliance.</p> <ul style="list-style-type: none"> <li>• Do NOT store flammable materials in the appliance's vicinity.</li> <li>• Do NOT use gasoline, lantern fuel, kerosene, charcoal lighter fluid or similar liquids in this appliance.</li> <li>• Combustible materials may ignite.</li> </ul>

## D. Frequently Asked Questions

ISSUE	SOLUTIONS
Condensation on the glass	This is a result of gas combustion and temperature variations. As the appliance warms, this condensation will disappear.
Blue flames	This is a result of normal operation and the flames will begin to yellow as the appliance is allowed to burn for 20 to 40 minutes.
Odor from appliance	When first operated, this appliance may release an odor for the first several hours. This is caused by the curing of the paint and the burning off of any oils remaining from manufacturing. Odor may also be released from finishing materials and adhesives used around the appliance.
Film on the glass	This is a normal result of the curing process of the paint and logs. Glass should be cleaned within 3 to 4 hours of initial burning to remove deposits left by oils from the manufacturing process. A non-abrasive cleaner such as gas fireplace glass cleaner may be necessary. See your dealer.
Metallic noise	Noise is caused by metal expanding and contracting as it heats up and cools down, similar to the sound produced by a furnace or heating duct. This noise does not affect the operation or longevity of the appliance.
Is it normal to see the pilot flame burn continually?	In an Intellifire ignition system it is normal to see the pilot flame, but it should turn off when ON/OFF is turned off. In a standing pilot system the pilot will always stay on.

# 14 Troubleshooting

With proper installation, operation, and maintenance your gas appliance will provide years of trouble-free service. If you do experience a problem, this troubleshooting guide will assist a qualified service person in the diagnosis of a problem and the corrective action to be taken. This troubleshooting guide can only be used by a qualified service technician.

## A. Intellifire Ignition System

Symptom	Possible Cause	Corrective Action
1. The ignitor/module makes noise, but no spark.	a. Incorrect wiring.	Verify "S" wire (white) for sensor and "I" wire (orange) for ignitor are connected to correct terminals on module and pilot assembly. Reversed wires at the module may cause system to make sparking noise, but spark may not be present at pilot hood.
	b. Loose connections or electrical shorts in the wiring.	Verify no loose connections or electrical shorts in wiring from module to pilot assembly. Rod closest to pilot hood should be ignitor. Verify connections underneath pilot assembly are tight; also verify connections are not grounding out to metal chassis, pilot burner, pilot enclosure, mesh screen if present, or any other metal object.
	c. Ignitor gap is too large.	Verify gap of igniter to pilot hood. The gap should be approximately .17 inch or 1/8 inch.
	d. Faulty module.	Turn ON/OFF rocker switch or wall switch to OFF position. Remove ignitor wire "I" from module. Place ON/OFF Rocker switch or wall switch in ON position. Hold ground wire about 3/16 inch away from "I" terminal on module. If there is no spark at "I" terminal module must be replaced. If there is a spark at "I" terminal, module is fine. Inspect pilot assembly for shorted sparker wire or cracked insulator around electrode.
2. Pilot won't light, there is no noise or spark.	a. Transformer installed correctly.	Verify that transformer is installed and plugged into module. Check voltage of transformer under load at spade connection on module with ON/OFF switch in ON position. Acceptable readings of a good transformer are between 3.2 and 2.8 volts AC.
	b. A shorted or loose connection in wiring configuration or wiring harness.	Remove and reinstall the wiring harness that plugs into module. Verify there is a tight fit. Verify pilot assembly wiring to module. Remove and verify continuity of each wire in wiring harness.
	c. Improper wall switch wiring.	Verify that 110/VAC power is "ON" to junction box.
	d. Module not grounded.	Verify black ground wire from module wire harness is grounded to metal chassis of appliance.
	e. Faulty module.	Turn ON/OFF rocker switch or wall switch to OFF position. Remove ignitor wire "I" from module. Place ON/OFF Rocker switch or wall switch in ON position. Hold ground wire about 3/16 inch away from "I" terminal on module. If there is no spark at "I" terminal module must be replaced. If there is a spark at "I" terminal, module is fine. Inspect pilot assembly for shorted sparker wire or cracked insulator around electrode.
3. Pilot lights but continues to spark, and main burner will not ignite. (If the pilot continues to spark after the pilot flame has been lit, flame rectification has not occurred.)	a. A shorted or loose connection in sensor rod.	Verify all connections to wiring diagram in manual. Verify connections underneath pilot assembly are tight. Verify connections are not grounding out to metal chassis, pilot burner, pilot enclosure or screen if present, or any other metal object.
	b. Poor flame rectification or contaminated sensor rod.	Verify that flame is engulfing sensor rod. If the pilot assembly does not have a ground strap, consider installing one to increase flame rectification. Verify correct pilot orifice is installed and inlet gas specifications. Flame carries rectification current, not the gas. If flame lifts from pilot hood, the circuit is broken. A wrong orifice or too high an inlet pressure can cause pilot flame to lift. The sensor rod may be contaminated. Clean sensor rod with emery cloth.

## Intellifire Ignition System - (continued)

Symptom	Possible Cause	Corrective Action
3. (Continued) Pilot lights but continues to spark, and main burner will not ignite. (If the pilot continues to spark after the pilot flame has been lit, flame rectification has not occurred.)	c. Module is not grounded.	Verify that module is securely grounded to metal chassis of appliance. Verify that wire harness is firmly connected to module.
	d. Damaged pilot assembly or dirty sensor rod.	Verify that ceramic insulator around the sensor rod is not cracked, damaged, or loose. Verify connection from sensor rod to white sensor wire. Clean sensor rod with emery cloth to remove any contaminants that may have accumulated on sensor rod. Verify continuity with a multimeter with ohms set at lowest range.
	e. Faulty module.	Turn ON/OFF rocker switch or wall switch to OFF position. Remove ignitor wire "I" from module. Place ON/OFF Rocker switch or wall switch in ON position. Hold ground wire about 3/16 inch away from "I" terminal on module. If there is no spark at "I" terminal module must be replaced. If there is a spark at "I" terminal, module is fine. Inspect pilot assembly for shorted sparker wire or cracked insulator around electrode.
4. Pilot sparks, but Pilot will not light.	a. Correct gas supply.	Verify that incoming gas line ball valve is "open". Verify that inlet pressure reading is within acceptable limits, inlet pressure must not exceed 14 in. W.C.
	b. Ignitor gap is too large.	Verify that spark gap from ignitor to pilot hood is .17 in. or 1/8 in.
	c. Module is not grounded.	Verify module is securely grounded to metal chassis of appliance.
	d. Module voltage output / Valve/Pilot solenoid ohms readings.	Verify battery voltage is at least 2.7 volts. Replace batteries if voltage is below 2.7.



# 15 Maintaining and Servicing Appliance

## A. Maintenance Tasks

Although the frequency of appliance servicing and maintenance will depend on use and the type of installation, a qualified service technician should perform an appliance checkup at the beginning of each heating season.

### WARNING

Risk of injury or property damage.

#### Before servicing:

- Turn off gas.
- Turn off electricity to appliance.
- Disable remote control, if one is present.
- Ensure appliance is completely cooled.

#### After servicing:

- Replace any screen or barrier that was removed.
- Reseal and reinstall any venting removed for servicing.

### WARNING

Annual inspection by qualified technician recommended.

#### Check:

- Condition of doors, surrounds and fronts.
- Condition of glass, glass assembly and glass seal.
- Obstructions of combustion and ventilation air.
- Condition of logs.
- Condition of firebox.
- Burner ignition and operation.
- Burner air shutter adjustment
- Gas connections and fittings.
- Obstructions of termination cap.



#### Clean:

- Glass
- Air passageways, grilles, control compartment
- Burner, burner ports

#### Risk of:

- Fire
- Delayed ignition or explosion
- Exposure to combustion fumes
- Odors



### CAUTION

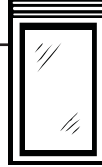

Handle glass assembly with care.

**Note:** Clean glass after initial 3-4 hours operation. **Longer operation without cleaning glass may cause a permanent white film on glass.**

#### When cleaning glass door:

- Avoid striking, scratching or slamming glass.
- Do NOT use abrasive cleaners.
- Use a hard water deposit glass cleaner on white film.
- Do NOT clean glass when hot.
- Turn off appliance after 3-4 hours of operation and **ALLOW TO COOL.**
- Remove and clean glass assembly.
- Replace glass assembly and operate appliance for additional 12 hours.

Refer to maintenance instructions.

### WARNING



Inspect external vent cap regularly.

- Ensure no debris blocks cap.



- Combustible materials blocking cap may ignite.
- Restricted air flow affects burner operation.



## B. Replacing Light Bulb

1. Remove the front and glass by following the “Placing the Embers Material” section.
2. Remove the logs and grate.
3. Remove the burner by unscrewing the two screws on the back of the burner and the two screws by the pilot using a 1/4 inch hex driver. Gently move the pilot out of the way and slide the burner out.

### CAUTION

Skin oils can cause early bulb failure.

- Do not touch bulb with bare hands.
- Use paper towel or rubber gloves when handling bulb.
- If bulb has been touched, wipe it clean with rubbing alcohol.

3. Slide the orange lens to the right to open the bulb cavity (see Figure 15.1). Remove old bulb. Replace the bulb with a 75 watt or less halogen bulb. See Service Parts List.



Figure 15.1

5. Slide the lens back over the bulb cavity. Place the burner back into place. Start the two metal strips into the slots on the burner then guide the burner neck onto the orifice. Make sure the burner neck is fully engaged onto the orifice. Try to move the burner side to side, the burner should not move if it is fully engaged onto the orifice. Attach the burner with the two screws removed in Step 3. Attach the pilot with the two screws removed in Step 3.
6. Place the grate onto the burner. The back of the right tine drops into the hole on the right rear of the burner. The shorter left tine is pushed back into the half-hole on the left side of the burner. Be sure to push the grate all the way down to the floor and firmly back into its holder.

Inspect	Maintenance Tasks
Doors, Surrounds and Fronts	1. Assess condition of screen and replace as necessary. Recommend addition of screen if one is not present.
	2. Inspect for scratches, dents or other damage and repair as necessary.
	3. Verify no obstructions to airflow through the louvers.
	4. Verify maintenance of proper clearance to combustible household objects.
Gasket Seal, Glass Assembly and Glass	1. Inspect gasket seal and its condition.
	2. Inspect glass panels for scratches and nicks that can lead to breakage when exposed to heat.
	3. Confirm there is no damage to glass or glass frame. Replace as necessary.
	4. Verify that latches engage properly, clip studs are not stripped, and glass attachment components are intact and operating properly. Replace as necessary.
	5. Clean glass. Replace glass assembly if severely coated with silicate deposits that cannot be removed.
Valve Compartment and Firebox Top	1. Vacuum and wipe out dust, cobwebs, debris or pet hair. Use caution when cleaning these areas. Screw tips that have penetrated the sheet metal are sharp and should be avoided.
	2. Remove any foreign objects.
	3. Verify unobstructed air circulation.
Logs	1. Inspect for broken, damaged, or missing logs. Replace as necessary.
	2. Verify correct log placement and no flame impingement causing sooting. Correct as necessary.
Firebox	1. Inspect for paint condition, warpage, corrosion or perforation. Sand and repaint as necessary.
	2. Replace appliance if firebox has been perforated.
Burner Ignition and Operation	1. Verify burner is properly secured and aligned with pilot or igniter.
	2. Clean off burner top, inspect for plugged ports, corrosion or deterioration. Replace burner if necessary.
	3. Replace ember materials with new dime-size and shape pieces. Do not block ports or obstruct lighting paths.
	4. Check for smooth lighting and ignition carryover to all ports. Verify there is no ignition delay.
	5. Inspect for lifting or other flame problems.
	6. Verify air shutter is clear of dust and debris.
	7. Inspect orifice for soot, dirt or corrosion.
	8. Verify manifold and inlet pressures. Adjust regulator as required.
	9. Inspect pilot flame strength. Clean or replace orifice as necessary.
	10. Inspect thermocouple/thermopile or IPI sensor rod for soot, corrosion and deterioration. Clean with emery cloth or replace as required.
	11. Verify millivolt output. Replace as necessary.
Venting	1. Inspect venting for blockage or obstruction such as bird nests, leaves, etc.
	2. Confirm that termination cap remains clear and unobstructed by plants, etc.
	3. Verify that termination cap clearance to subsequent construction (building additions, decks, fences or sheds) has been maintained.
	4. Inspect for corrosion or separation.
	5. Verify weather stripping, sealing and flashing remains intact.
	6. Inspect draft shield to verify it is not bent, damaged or missing.
Remote controls	1. Verify operation of remote.
	2. Replace batteries in remote transmitters and battery-powered receivers.
	3. Verify batteries have been removed from battery back-up IPI systems to prevent premature battery failure or leaking.

# 16 Reference Materials

## A. Appliance Dimension Diagram

Dimensions are actual appliance dimensions. Use for reference only. For framing dimensions and clearances refer to Section 3.

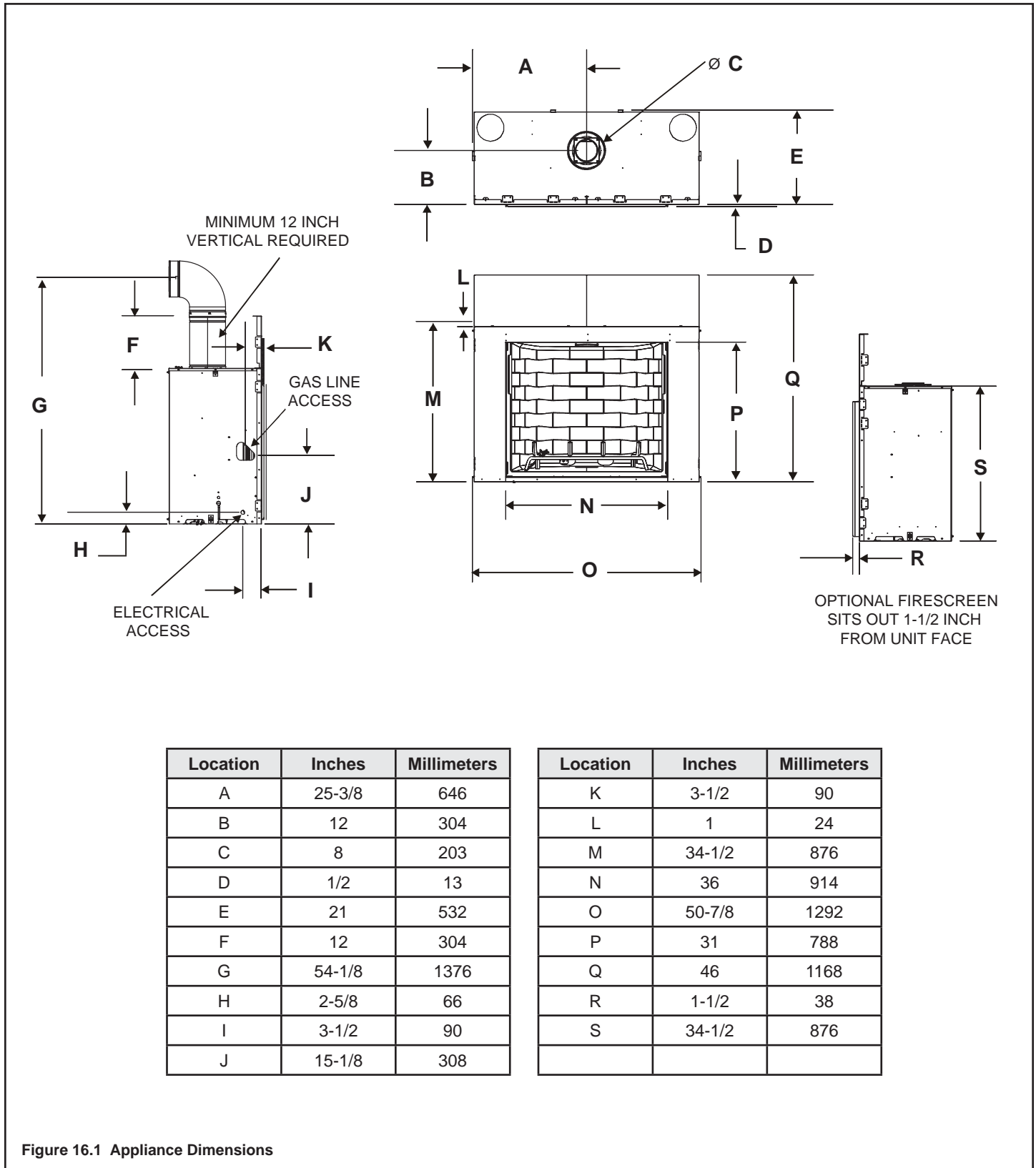
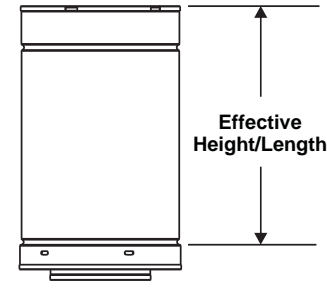

Figure 16.1 Appliance Dimensions

## B. Vent Components Diagrams



Effective Height/Length

DVP Pipe (see chart)

Pipe	Effective Length	
	Inches	Millimeters
DVP4	4	102
DVP6	6	152
DVP12	12	305
DVP24	24	610
DVP36	36	914
DVP48	48	1219
DVP6A	3 to 6	76 to 152
DVP12A	3 to 12	76 to 305
DVP12MI	3 to 12	76 to 305
DVP24MI	3 to 24	76 to 610

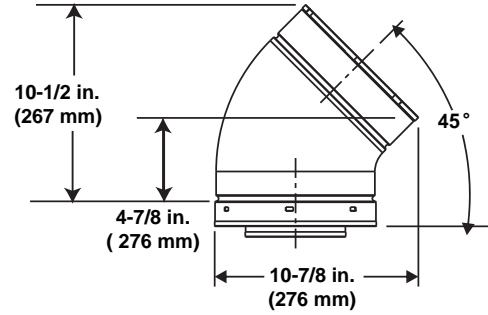

DVP45 (45° Elbow)

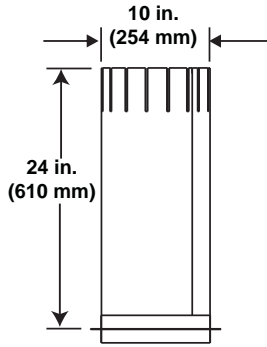

DVP-AS (Attic Shield)

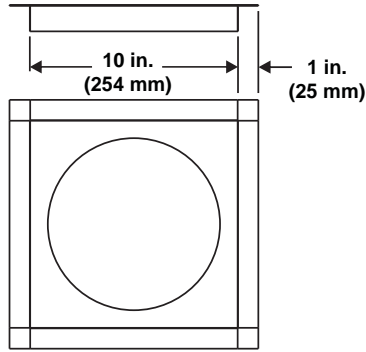

DVP-FS (Ceiling Firestop)

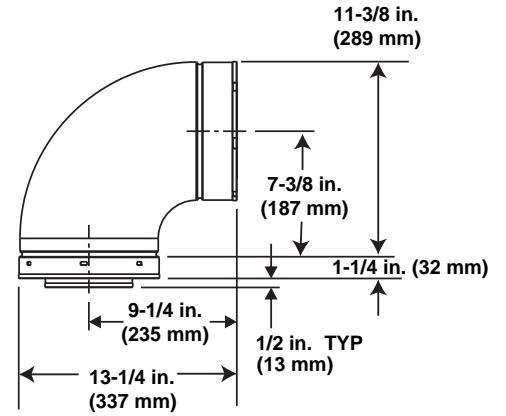

DVP90ST (90° Elbow)

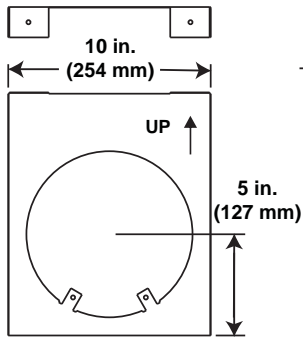

DVP-HVS (Vent Support)

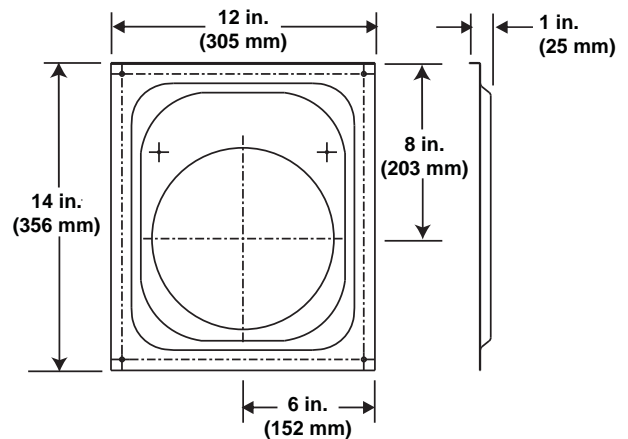
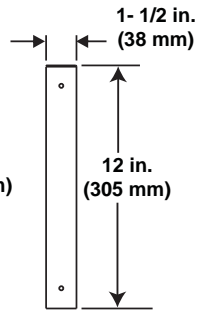

DVP-WS (Wall Shield Firestop)

Figure 16.2 DVP vent components

## B. Vent Components Diagrams (continued)

Note: Heat shields MUST overlap by a minimum of 1-1/2 in. (38 mm). The heat shield is designed to be used on a wall 4 in. to 7-1/4 in. (102 mm to 184 mm) thick. If wall thickness is less than 4 in. (102 mm) the existing heat shields must be field trimmed. If wall thickness is greater than 7-1/4 in. (184 mm) a DVP-HSM-B will be required.

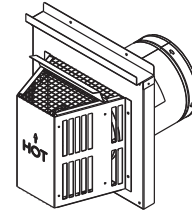
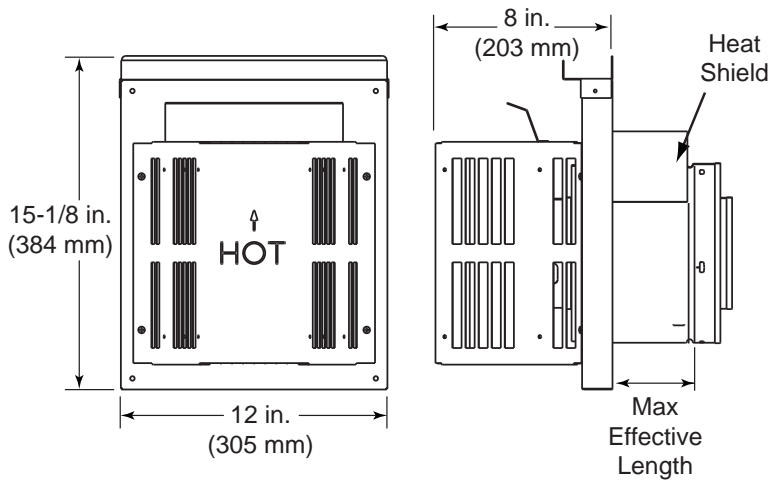

Term Cap	Minimum Effective Length	Maximum Effective Length
Trap1	3-1/8 in.	4-5/8 in.
	79 mm	117 mm
Trap2	5-3/8 in.	9-3/8 in.
	137 mm	238 mm

**DVP-TRAP**  
Horizontal Termination Cap

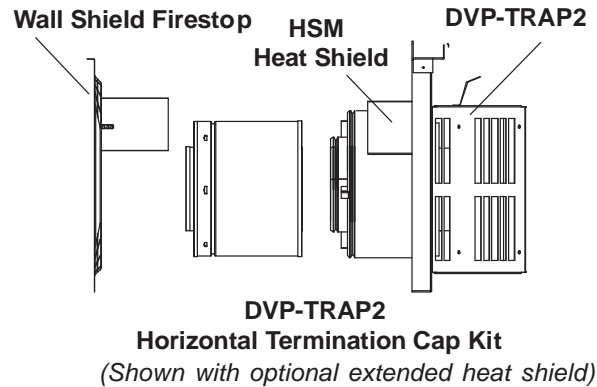
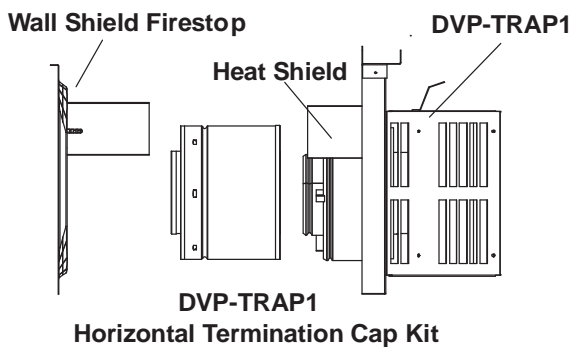

**DVP-TRAP1**  
Horizontal Termination Cap Kit

**DVP-TRAP2**  
Horizontal Termination Cap Kit  
(Shown with optional extended heat shield)

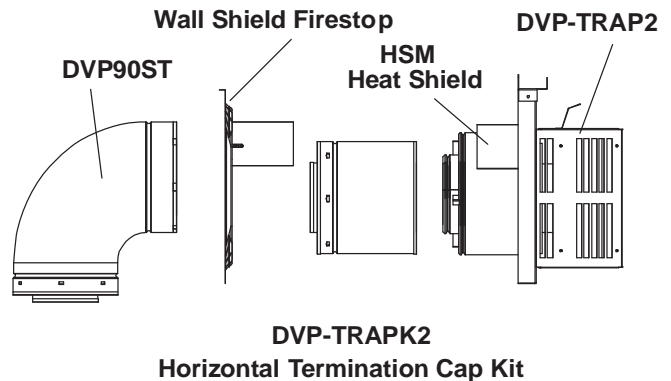
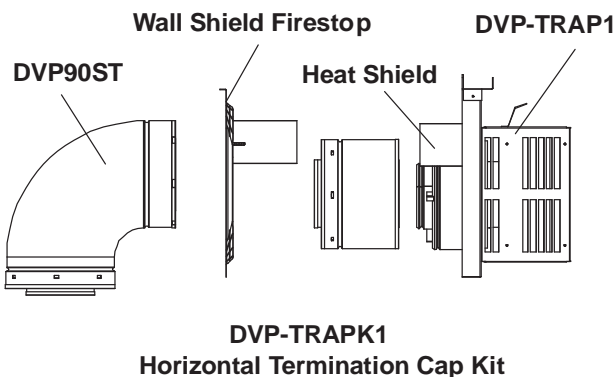

**DVP-TRAPK1**  
Horizontal Termination Cap Kit

**DVP-TRAPK2**  
Horizontal Termination Cap Kit

Figure 16.3 DVP vent components

## B. Vent Components Diagrams (continued)

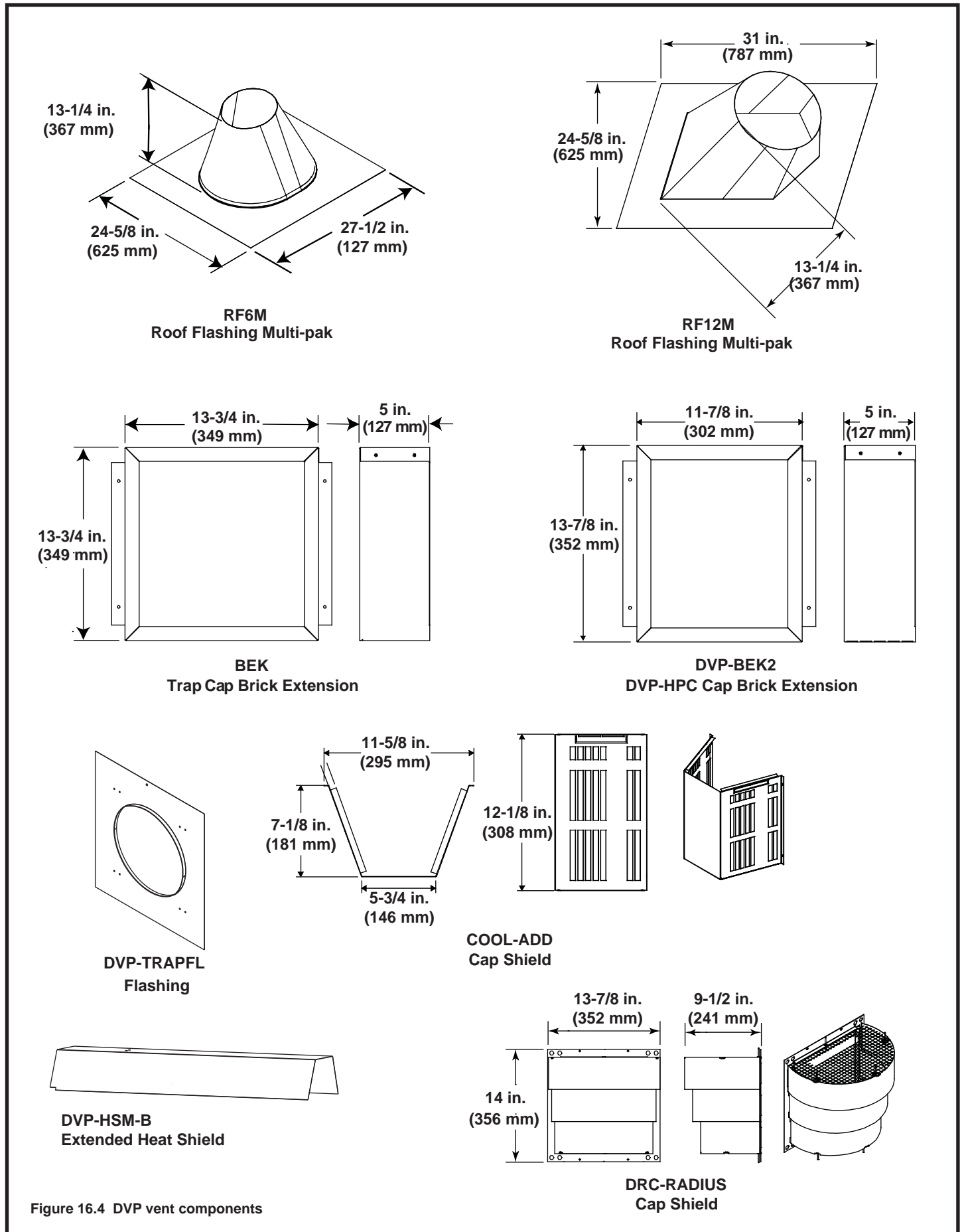
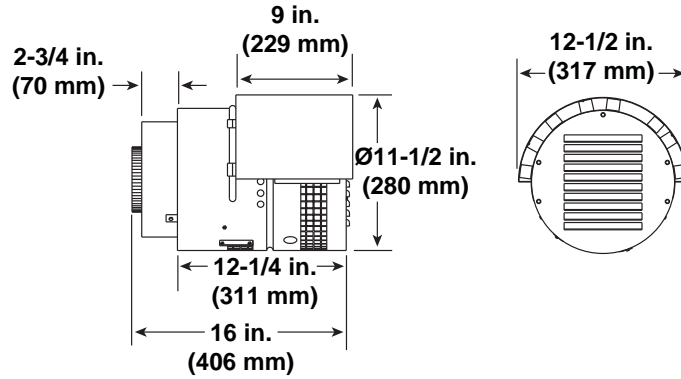

Figure 16.4 DVP vent components



## B. Vent Components Diagrams (continued)



**PVK-80**

*(For use with IPI and DSI appliances only.)*

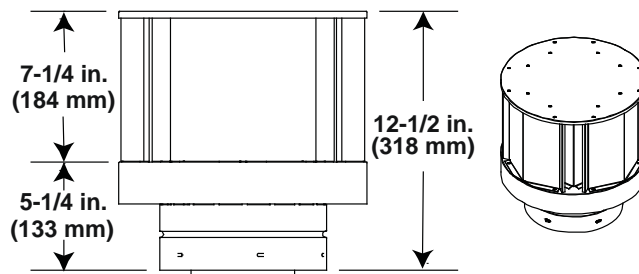

**DVP-TVHW**

**Vertical Termination Cap (Highwind)**

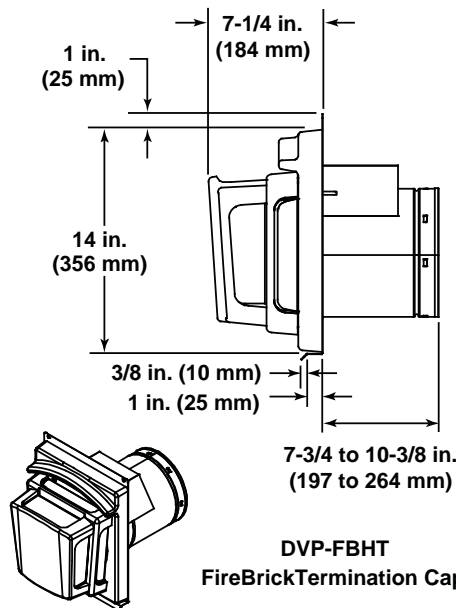

7-3/4 to 10-3/8 in.  
(197 to 264 mm)

**DVP-FBHT**  
**Fire Brick Termination Cap**

Figure 16.5 DVP vent components

## B. Vent Components Diagrams (continued)

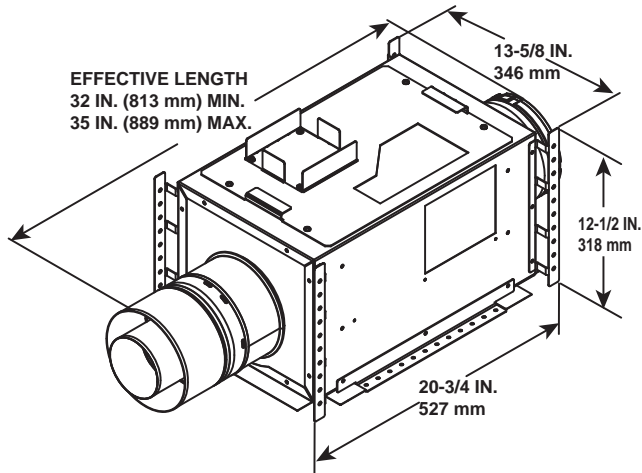

**PVI-SLP**  
Power Vent Inline

Optional Wire Harness	
DESCRIPTION	PART NUMBER
10 ft. PV Wire Harness	PVI-WH10
20 ft. PV Wire Harness	PVI-WH20
40 ft. PV Wire Harness	PVI-WH40
60 ft. PV Wire Harness	PVI-WH60
80 ft. PV Wire Harness	PVI-WH80
100 ft. PV Wire Harness	PVI-WH100

**Note:** Wire harnesses required to power the PVI-SLP connect to the appliance and are ordered separately from PVI-SLP. Contact your dealer to order.

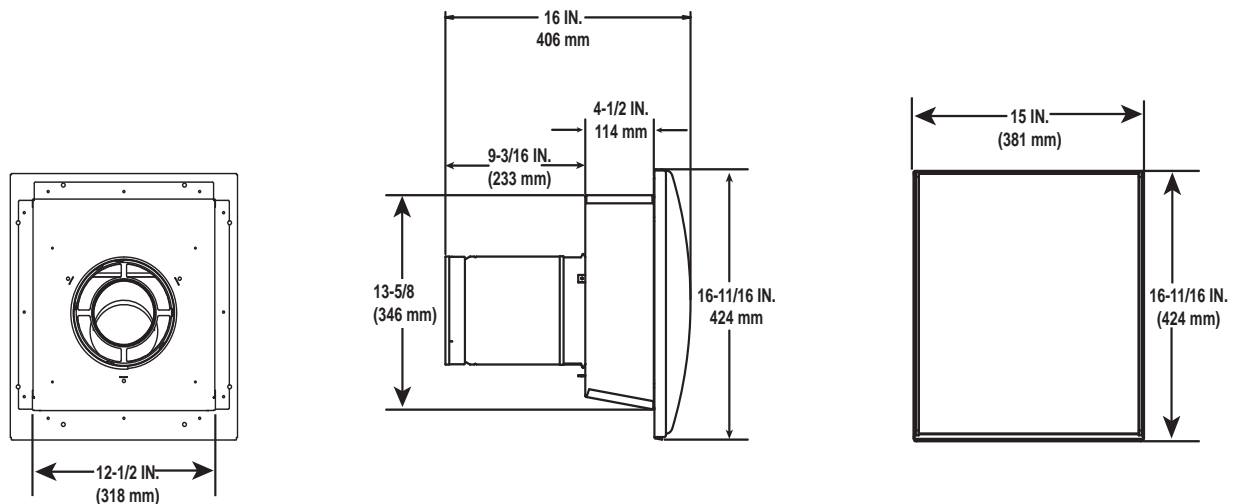

**SLP-LPC**  
SLP Low Profile Cap

Figure 16.6 Vent Components

### Log Set Assembly

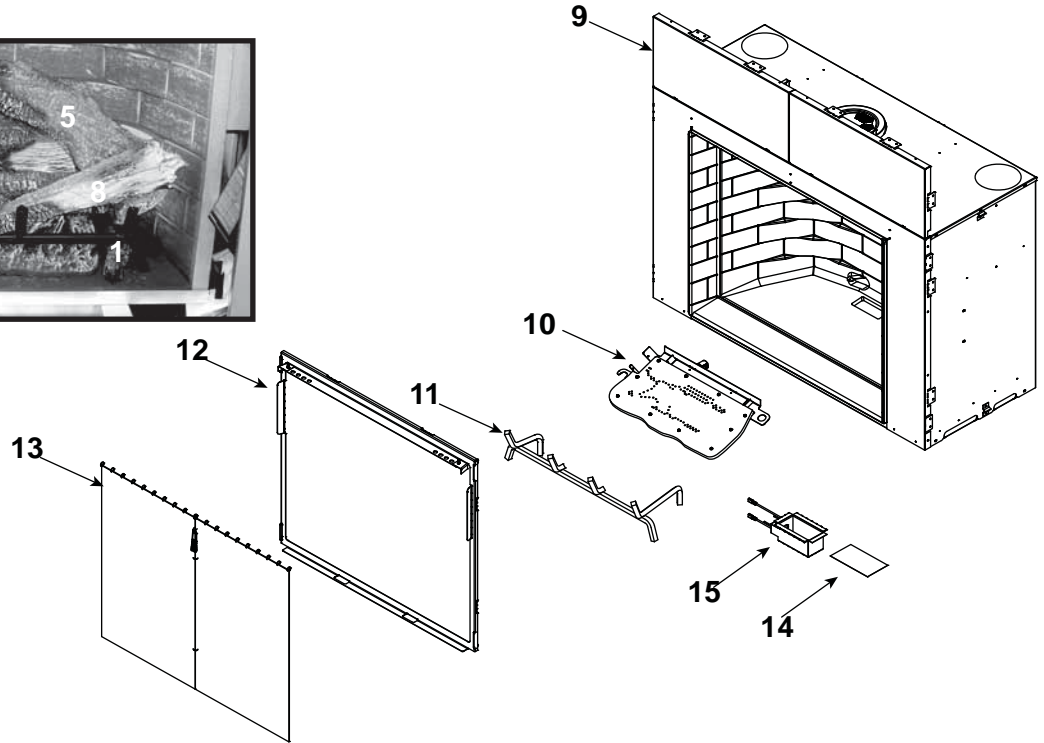
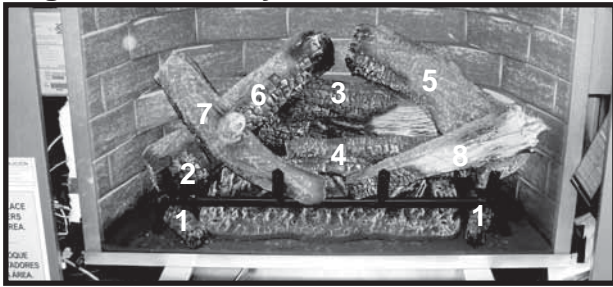

IMPORTANT: THIS IS DATED INFORMATION. When requesting service or replacement parts for your appliance please provide model number and serial number. All parts listed in this manual may be ordered from an authorized dealer.



**Stocked at Depot**

ITEM	DESCRIPTION	COMMENTS	PART NUMBER	
	Log Set Assembly		LOGS-ESCAPE36	Y
1	Log 1	Qty 2 req	SRV2012-081	
2	Log 2		SRV2012-082	
3	Log 3		SRV2012-083	
4	Log 4		SRV2012-084	
5	Log 5		SRV2012-085	
6	Log 6		SRV2012-086	
7	Log 7		SRV2012-087	
8	Log 8		SRV2012-088	
9	Panel Metal		2012-185	
10	Burner NG	Pre 002868727	SRV2012-013-NG	Y
		Post 002868727	2012-013	Y
	Burner LP	Pre 002868727	SRV2012-013-LP	Y
		Post 002868727	2012-013	Y
11	Log Grate		2012-002	
12	Glass Door Assembly		GLA-ESCAPE	Y
13	Mesh Assembly		MESH-ESCAPE	Y
14	Orange Kapton Lens		2012-114	Y
15	Light Socket Assembly		2012-010	

Additional service part numbers appear on following page.

### IPI Valve Assembly

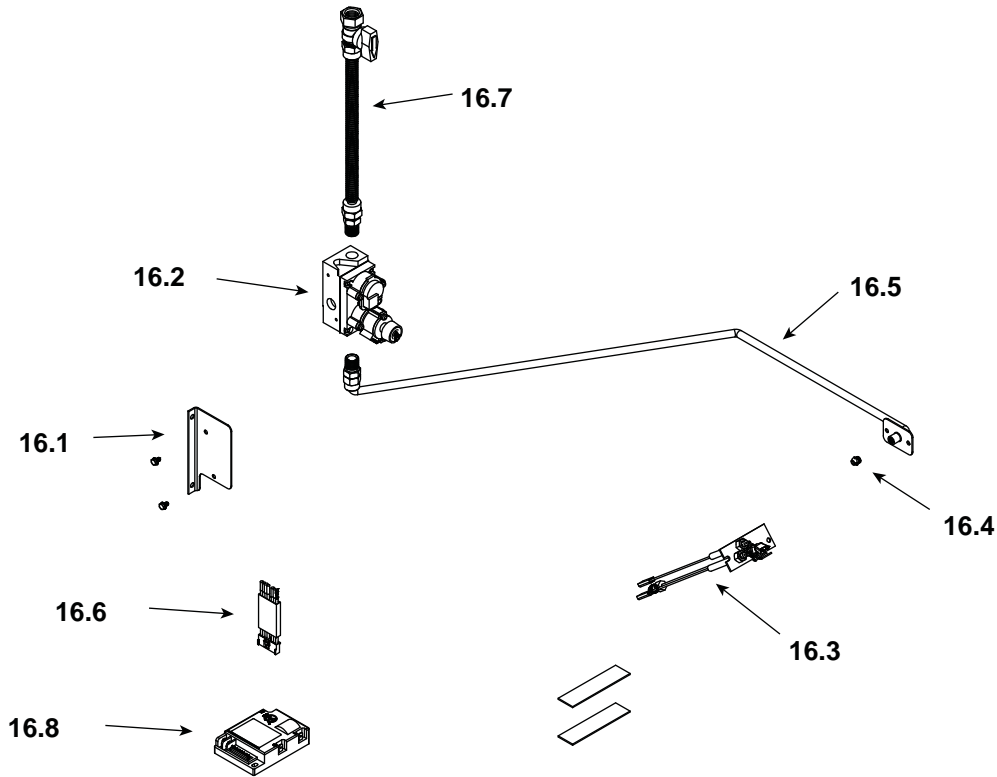

IMPORTANT: THIS IS DATED INFORMATION. When requesting service or replacement parts for your appliance please provide model number and serial number. All parts listed in this manual may be ordered from an authorized dealer.



**Stocked at Depot**

ITEM	DESCRIPTION	COMMENTS	PART NUMBER	
16.1	Valve Bracket		2012-106	
16.2	Valve (NG)		750-500	Y
	Valve (LP)		750-501	Y
16.3	Pilot Assembly NG	Pre 002868727	385-510A	Y
		Post 002868727	2090-012	Y
	Pilot Assembly LP	Pre 002868727	385-511A	Y
		Post 002868727	2090-013	Y
16.4	Burner Orifice (#30C) NG		582-830	Y
	Burner Orifice (#49C) LP		582-849	Y
16.5	Flexible Gas Connector		2012-008	Y
16.6	Wire Assembly		593-590A	Y
16.7	Flex Ball Valve Assembly		302-320A	Y
16.8	Module		593-592	Y

Additional service part numbers appear on following page.

## C. Service Parts List

ESCAPE-36DV

IMPORTANT: THIS IS DATED INFORMATION. When requesting service or replacement parts for your appliance please provide model number and serial number. All parts listed in this manual may be ordered from an authorized dealer.



**Stocked  
at Depot**

ITEM	DESCRIPTION	COMMENTS	PART NUMBER	Stocked at Depot
	2 inch Jumper Wire		2012-206	Y
	75 Halogen Bulb mini-can base		700-540	Y
	Battery Pack		593-594A	Y
	Fiber Patch Kit		SRV-PACK	
	Flue Restrictor ( 3" Diameter)		2012-124	
	Glass Latch	Pkg of 2	386-122A/2	Y
	Ground Strap	Pre 002868727	385-512	
		Post 002868727	N/A	
	Junction Box		4021-013	Y
	Mesh Rod		2012-158	
	Mineral Wool		050-721	
	Multi-functional Wall Switch		WSK-MLT	
	Mystic Embers		MYSTIC-EMBERSXL	
	Non-Combustible Assembly		2012-036	
	ON/Off Rocker Switch		060-521A	Y
	Pilot Bracket	Pre 002868727	2012-108	
		Post 002868727	N/A	
	Refractory Panels (Sold as set only)	Pre 002768335	FRONT-PANEL-KIT	
		Post 002768335	E36-PANEL-KIT	
→	Touch up Paint,Logs	Black	SRV999-404	
		Brown	SRV999-403	
		Split	SRV999-472	
	Wall Switch Wire		2095-550	Y
	Wire Plug Assembly		2005-021	Y
	Conversion Kit NG		NGK-ESCAPE-36DV	Y
	Conversion Kit LP		LPK-ESCAPE-36DV	Y
	Pilot Orifice NG	Pre 002868727	446-505	Y
		Post 002868727	593-528	Y
	Pilot Orifice LP	Pre 002868727	446-517	Y
		Post 002868727	593-527	Y
	Regulator NG		NGK-DXV	Y
	Regulator LP		LPK-DXV	Y

## D. Limited Lifetime Warranty

### Hearth & Home Technologies Inc. LIMITED LIFETIME WARRANTY

Hearth & Home Technologies Inc., on behalf of its hearth brands ("HHT"), extends the following warranty for HHT gas, wood, pellet, coal and electric hearth appliances that are purchased from an HHT authorized dealer.

#### **WARRANTY COVERAGE:**

HHT warrants to the original owner of the HHT appliance at the site of installation, and to any transferee taking ownership of the appliance at the site of installation within two years following the date of original purchase, that the HHT appliance will be free from defects in materials and workmanship at the time of manufacture. After installation, if covered components manufactured by HHT are found to be defective in materials or workmanship during the applicable warranty period, HHT will, at its option, repair or replace the covered components. HHT, at its own discretion, may fully discharge all of its obligations under such warranties by replacing the product itself or refunding the verified purchase price of the product itself. The maximum amount recoverable under this warranty is limited to the purchase price of the product. This warranty is subject to conditions, exclusions and limitations as described below.

#### **WARRANTY PERIOD:**

Warranty coverage begins on the date of original purchase. In the case of new home construction, warranty coverage begins on the date of first occupancy of the dwelling or six months after the sale of the product by an independent, authorized HHT dealer/ distributor, whichever occurs earlier. The warranty shall commence no later than 24 months following the date of product shipment from HHT, regardless of the installation or occupancy date. The warranty period for parts and labor for covered components is produced in the following table.

The term "Limited Lifetime" in the table below is defined as: 20 years from the beginning date of warranty coverage for gas appliances, and 10 years from the beginning date of warranty coverage for wood, pellet, and coal appliances. These time periods reflect the minimum expected useful lives of the designated components under normal operating conditions.

Warranty Period		HHT Manufactured Appliances and Venting							Components Covered
Parts	Labor	Gas	Wood	Pellet	EPA Wood	Coal	Electric	Venting	
1 Year		X	X	X	X	X	X	X	All parts and material except as covered by Conditions, Exclusions, and Limitations listed
2 years				X	X	X			Igniters, electronic components, and glass
		X	X	X	X	X			Factory-installed blowers
				X					Molded refractory panels
3 years				X					Firepots and burnpots
5 years	1 year			X	X				Castings and baffles
7 years	3 years		X	X	X				Manifold tubes, HHT chimney and termination
10 years	1 year	X							Burners, logs and refractory
Limited Lifetime	3 years	X	X	X	X	X			Firebox and heat exchanger
90 Days		X	X	X	X	X	X	X	All replacement parts beyond warranty period

See conditions, exclusions, and limitations on next page.



## **D. Limited Lifetime Warranty (*continued*)**

### **WARRANTY CONDITIONS:**

- This warranty only covers HHT appliances that are purchased through an HHT authorized dealer or distributor. A list of HHT authorized dealers is available on the HHT branded websites.
- This warranty is only valid while the HHT appliance remains at the site of original installation.
- Contact your installing dealer for warranty service. If the installing dealer is unable to provide necessary parts, contact the nearest HHT authorized dealer or supplier. Additional service fees may apply if you are seeking warranty service from a dealer other than the dealer from whom you originally purchased the product.
- Check with your dealer in advance for any costs to you when arranging a warranty call. Travel and shipping charges for parts are not covered by this warranty.

### **WARRANTY EXCLUSIONS:**

This warranty does not cover the following:

- Changes in surface finishes as a result of normal use. As a heating appliance, some changes in color of interior and exterior surface finishes may occur. This is not a flaw and is not covered under warranty.
- Damage to printed, plated, or enameled surfaces caused by fingerprints, accidents, misuse, scratches, melted items, or other external sources and residues left on the plated surfaces from the use of abrasive cleaners or polishes.
- Repair or replacement of parts that are subject to normal wear and tear during the warranty period. These parts include: paint, wood, pellet and coal gaskets, firebricks, grates, flame guides, light bulbs, batteries and the discoloration of glass.
- Minor expansion, contraction, or movement of certain parts causing noise. These conditions are normal and complaints related to this noise are not covered by this warranty.
- Damages resulting from: (1) failure to install, operate, or maintain the appliance in accordance with the installation instructions, operating instructions, and listing agent identification label furnished with the appliance; (2) failure to install the appliance in accordance with local building codes; (3) shipping or improper handling; (4) improper operation, abuse, misuse, continued operation with damaged, corroded or failed components, accident, or improperly/incorrectly performed repairs; (5) environmental conditions, inadequate ventilation, negative pressure, or drafting caused by tightly sealed constructions, insufficient make-up air supply, or handling devices such as exhaust fans or forced air furnaces or other such causes; (6) use of fuels other than those specified in the operating instructions; (7) installation or use of components not supplied with the appliance or any other components not expressly authorized and approved by HHT; (8) modification of the appliance not expressly authorized and approved by HHT in writing; and/or (9) interruptions or fluctuations of electrical power supply to the appliance.
- Non-HHT venting components, hearth components or other accessories used in conjunction with the appliance.
- Any part of a pre-existing fireplace system in which an insert or a decorative gas appliance is installed.
- HHT's obligation under this warranty does not extend to the appliance's capability to heat the desired space. Information is provided to assist the consumer and the dealer in selecting the proper appliance for the application. Consideration must be given to appliance location and configuration, environmental conditions, insulation and air tightness of the structure.

### **This warranty is void if:**

- The appliance has been over-fired or operated in atmospheres contaminated by chlorine, fluorine, or other damaging chemicals. Over-firing can be identified by, but not limited to, warped plates or tubes, rust colored cast iron, bubbling, cracking and discoloration of steel or enamel finishes.
- The appliance is subjected to prolonged periods of dampness or condensation.
- There is any damage to the appliance or other components due to water or weather damage which is the result of, but not limited to, improper chimney or venting installation.

### **LIMITATIONS OF LIABILITY:**

- The owner's exclusive remedy and HHT's sole obligation under this warranty, under any other warranty, express or implied, or in contract, tort or otherwise, shall be limited to replacement, repair, or refund, as specified above. In no event will HHT be liable for any incidental or consequential damages caused by defects in the appliance. Some states do not allow exclusions or limitation of incidental or consequential damages, so these limitations may not apply to you. This warranty gives you specific rights; you may also have other rights, which vary from state to state. EXCEPT TO THE EXTENT PROVIDED BY LAW, HHT MAKES NO EXPRESS WARRANTIES OTHER THAN THE WARRANTY SPECIFIED HEREIN. THE DURATION OF ANY IMPLIED WARRANTY IS LIMITED TO DURATION OF THE EXPRESSED WARRANTY SPECIFIED ABOVE.

