

HARDWARE

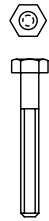

EIGHT (8)
HEX BOLTS



EIGHT (8)
NUTS



SIXTEEN (16)
FLAT
WASHERS

ASSEMBLY INSTRUCTIONS

1.) LOCATE THE TWO SIDE ASSEMBLIES AND SHELF ASSEMBLY. WHILE LAYING ON IT'S SIDE (FIG. A.) BOLT THE SHELF ASSEMBLY (THROUGH THE HOLES IN ITS SIDE) TO ONE SIDE ASSEMBLY THROUGH ITS LOWER SET OF HOLES. MAKE SURE THE SHELF SURFACE IS FACING AWAY FROM THE CASTERS.
(TYPICAL BOLTING PROCEDURE - PASS BOLT THROUGH WASHER ON EXTERNAL SIDE. ONCE BOLT HAS PASSED THROUGH TO INTERIOR PUT ON SECOND WASHER FOLLOWED BY NUT. HAND TIGHTEN ONLY.) REPEAT STEP WITH SECOND SIDE ASSEMBLY.

2.) STAND ASSEMBLY UPRIGHT ON CASTERS. LOCK THE SET OF LOCKING CASTERS TO MINIMIZE THE ROLLING OF CART DURING THE FOLLOWING STEPS.

3.) MATCH THE NUMERICAL NOTATION AT THE TOP OF THE SIDE ASSEMBLIES WITH NUMBERS ON INSIDE OF TABLE TOP SKIRT. THIS WILL ORIENT THE TOP PROPERLY.

4.) DROP THE TOP DOWN OVER THE LEGS, (FIG. 2.) WITH THE LEGS FITTING UP INSIDE OF THE TOP SKIRT. LINE UP THE BOLT HOLES IN THE SIDES OF THE TOP SKIRT WITH THE BOLT HOLES IN THE TOPS OF THE SIDE ASSEMBLIES AND BOLT PER METHOD IN STEP ONE.

5.) USING WRENCH GO BACK AND TIGHTEN ALL (8) BOLTS

6.) TABLE IS NOW READY TO HAVE GRILL LOWERED INTO PLACE. (FIG. 3) MAKE SURE THAT HINGE SIDE OF GRILL IS ORIENTED WITH CUT-OUT IN TABLE TOP.

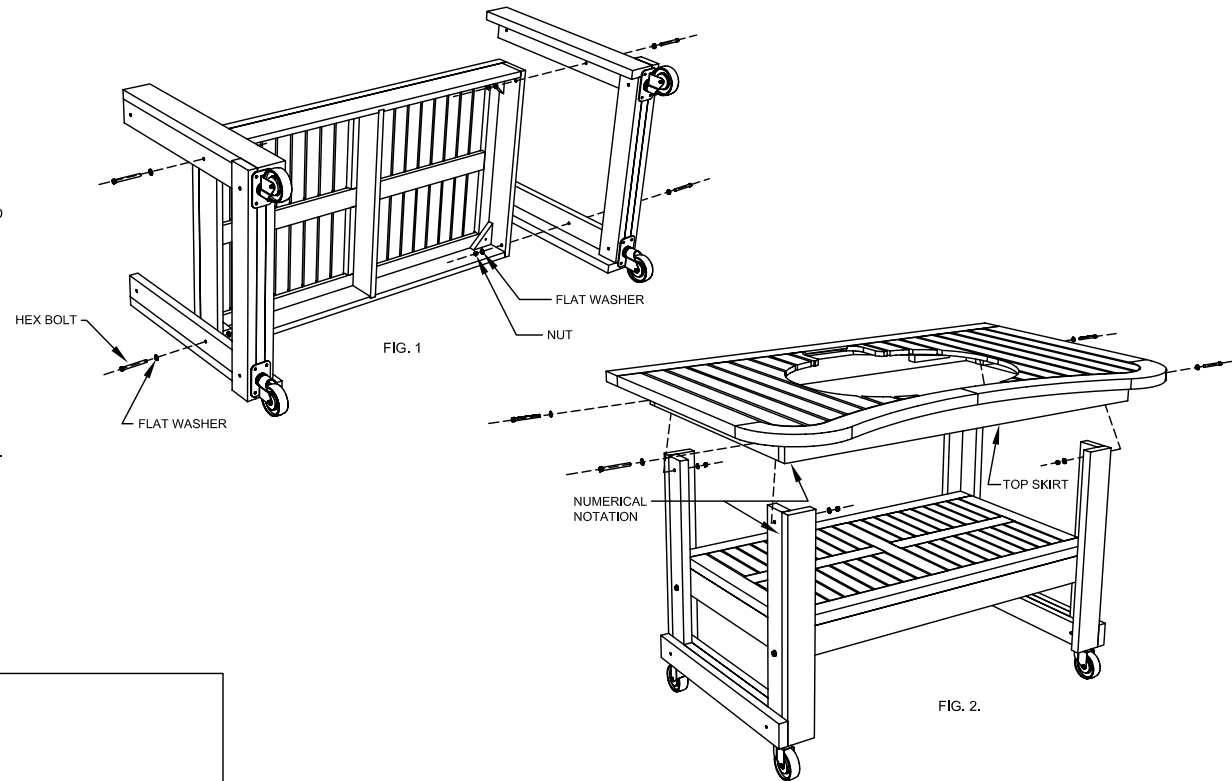

SUB-ASSEMBLIES

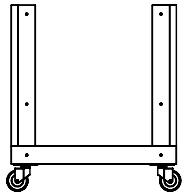

SIDE
ASSEMBLY

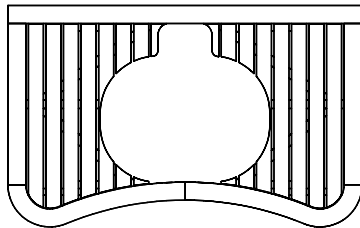

TOP
ASSEMBLY

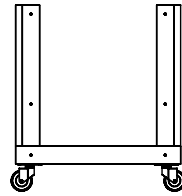

SIDE
ASSEMBLY

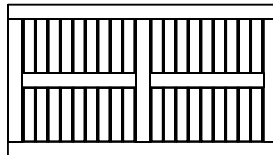

SHELF
ASSEMBLY

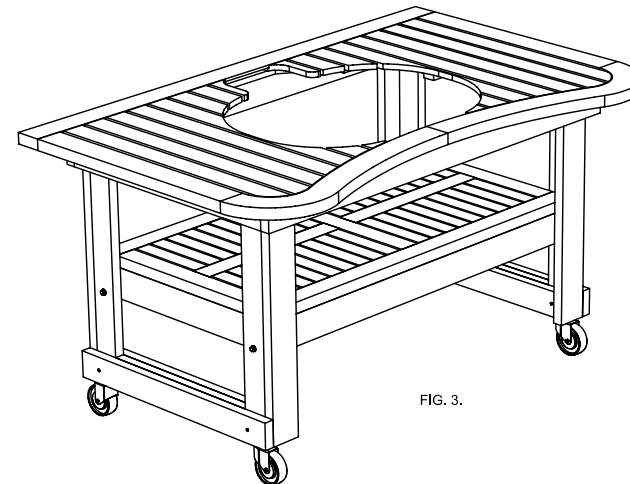

FIG. 3.