

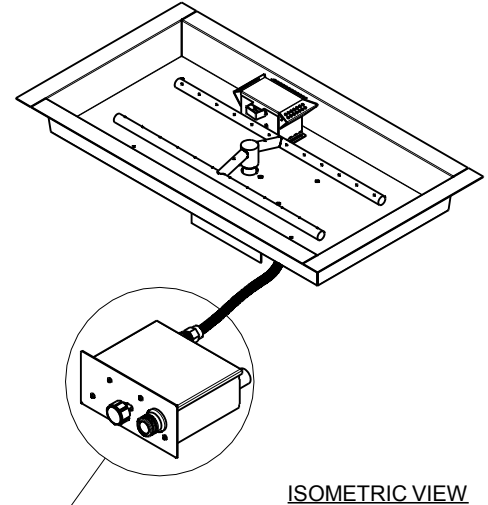

**Hearth Products Controls Co**  
**UL CERTIFIED-OUTDOOR USE ONLY**  
**FOR COMMERCIAL AND RESIDENTIAL USE**

HEARTH PRODUCTS CONTROLS  
 3050 PLAINFIELD RD.  
 KETTERING, OH 45432  
 TOLL FREE: 1-877-433-7001  
 PHONE: (937) 433-7000  
 FAX: (937) 433-0704  
 www.hpcfire.com

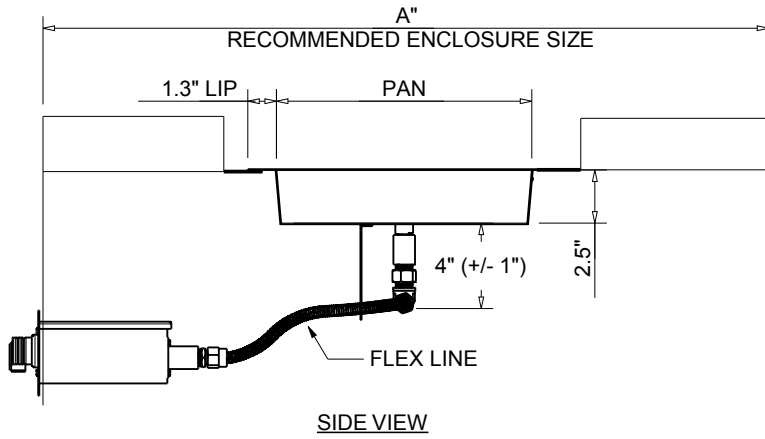

VALVE BOX DETAIL

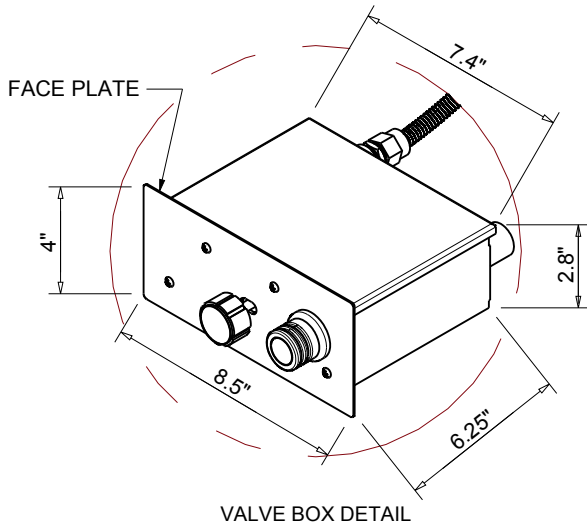

VALVE BOX DETAIL

SPARK IGNITION BY AA BATTERY  
 MATERIAL: 304 STAINLESS STEEL

PART NUMBERS	PAN	DIMENSION CHART			
		BURNER		A"	STND FLEX LINE LENGTH
		SIZE	BTU		
FPPK24X12-H-FLEX	24"X12"	18"X6"	75K	56LX28W	36"
FPPK30X12-H-FLEX	30"X12"	24"X6"	100K	56LX28W	36"
FPPK36X14-H-FLEX	36"X14"	30"X8"	125K	64LX32W	36"
FPPK42X14-H-FLEX	42"X14"	36"X8"	140K	64LX32W	36"
FPPK54X16-H-FLEX	54"X16"	48"X10"	140K	76LX38W	36"

Notes:

- PROPER VENTING
    - ENCLOSURES: Recommend 4 each 18 sq.in. vents on opposing sides (Minimum 2 each 18 sq.in. vents).
  - GAS SUPPLY - FOR USE WITH FIXED PIPING SYSTEMS ONLY - NOT FOR USE WITH SMALL TANKS.
    - Natural Gas: Operating Supply Pressure: Minimum: 6.0" W.C.; Maximum: 7.0" W.C.
    - LP Gas: Operating Supply Pressure: Minimum: 10.0" W.C.; Maximum: 11.0" W.C.
- IMPORTANT: Ensure any flex line that may be used from the permanent main fuel supply to the product is rated to the stated max btu of the product and certified to ANSI Z21.75\*CSA 6.27.
- MODIFICATION OF PRODUCT WILL VOID ANY CERTIFICATION AND WARRANTY.
  - FOLLOW ALL MANUFACTURER INSTALLATION INSTRUCTIONS AND LOCAL CODES.
  - ALL DIMENSIONS ARE CONSIDERED TRUE AND REFLECT MANUFACTURER'S SPECIFICATIONS AS OF THE REVISION DATE.
  - DO NOT SCALE DRAWING.
  - THESE DRAWINGS ARE FOR SIZING AND PLANNING PURPOSES. ALL INFORMATION CONTAINED HEREIN WAS CURRENT AT THE TIME OF DEVELOPMENT. THE MANUFACTURER'S RESPONSIBLE FOR THE ACCURACY OF THE DRAWING.
  - CONTRACTOR'S NOTE: FOR PRODUCT AND COMPANY INFORMATION VISIT [www.CADdetails.com/info](http://www.CADdetails.com/info) REFERENCE NUMBER 771-039.

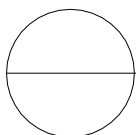

PUSH BUTTON/FLAME SENSING FIRE PIT INSERT - WITH FLEX LINE  
 RECTANGLE PAN - FPPK