

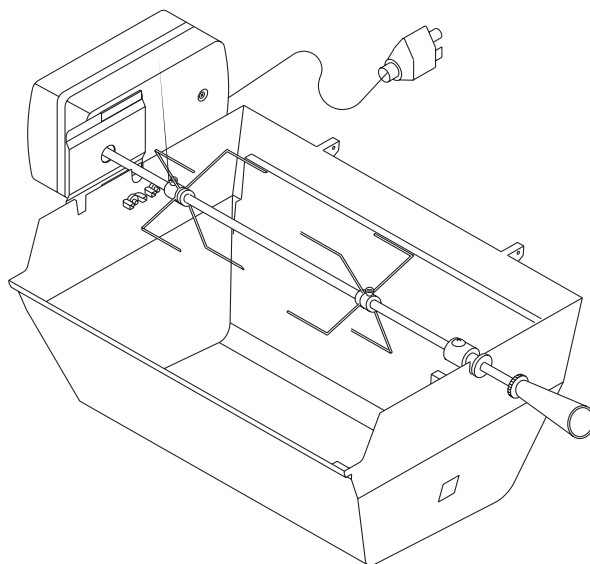

DPA51 HEAVY DUTY STANDARD ROTISSERIE INSTALLATION AND OPERATION INSTRUCTIONS



ABOUT ROTISSERIE COOKING

Because it rotates slowly over fire, lean meat or fowl cooked on a rotisserie requires less attention and achieves an excellent flavor and appetizing appearance. Direct heat rotisserie cooking over a single burner or side of a twin burner being fired is usually done at a low or medium burner setting.

The twin burner featured in some models allows indirect rotisserie cooking. The cooking grids must be removed when using the rotisserie. Turn on one side of the burner and load the meat on the spit rod so that it will rotate over the unfired side of the burner. Great barbeque flavor is still imparted into whatever food is prepared yet even less attention is required during cooking. (After indirect cooking is completed, it is suggested that the unfired side of the burner be lit for several minutes to burn off any droppings.)

CAUTION: Use protective gloves and care to protect you or your family from burns. Do not leave the rotisserie unit unattended.

WARNING: Do not expose rotisserie to weather elements.

WARNING: Electrical Grounding Instructions

This appliance is equipped with a three-prong (grounding) plug for your protection against shock hazard and should be plugged directly into a properly grounded three-prong receptacle. Do not cut or remove the grounding prong from this plug.

KEEP THIS OWNER'S MANUAL FOR FUTURE REFERENCE.

The optional rotisserie consists of the motor, spit rod, meat holders, motor bracket, spit rod locator sleeve and hardware.

1

Fasten the motor bracket (3) to the left side of the grill with two 10-24 x $\frac{1}{2}$ screws (2), and two 10-24 wing nuts (5). FIGURE 1.

FIGURE 1

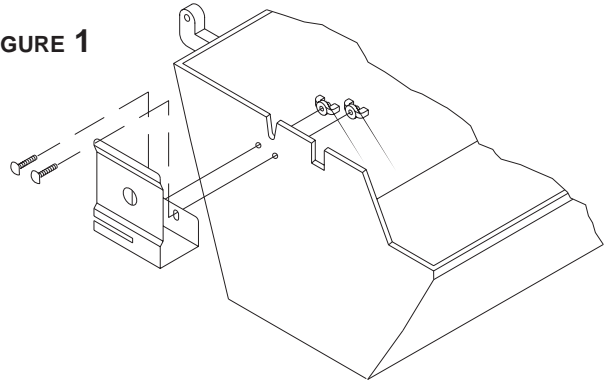

2

Slide motor into position on motor bracket. FIGURE 2.

FIGURE 2

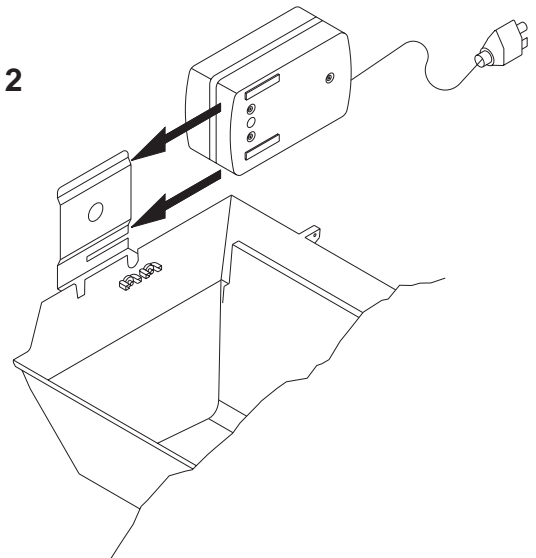

3

If separated, tightly fasten handle and thumb nut (7) onto threaded end of spit rod (8). Slide locator sleeve (9) on spit rod with set screw on inside of grill. Slide meat holders on spit rod and insert spit rod into rotisserie motor. FIGURE 3.

4

Slide locator sleeve (9) on spit rod until sleeve rests in slot on right side of grill.

5

Tighten screw in locator sleeve.

FIGURE 3

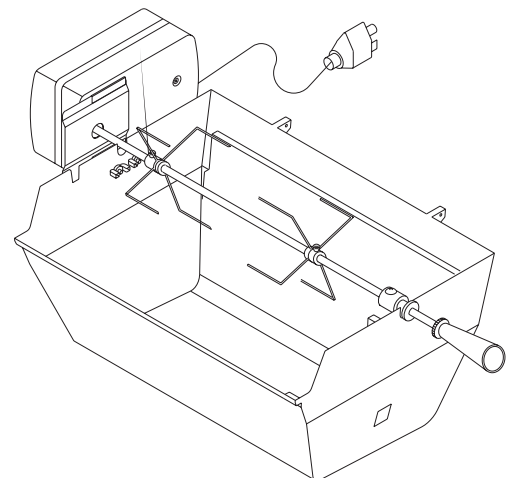

PREPARING MEATS FOR THE ROTISSERIE

Some amount of flare-up is desirable in outdoor cooking. It's the flare-up that imparts that great "barbeque flavor" to foods being prepared.

Excess fats should be trimmed from beef or pork to reduce the drippings of melted fat and prevent excessive flaring. Lower temperatures will also help prevent excessive flare-up.

An excellent collection of recipes tested on Broilmaster® gas grills is available. Ask your dealer or write to us about our gas barbeque cookbook.

NOTE: Suggestions from Broilmaster® owners for further uses of the rotisserie will be appreciated. If you have any ideas, write us!

ROTISSERIE USE

1

Warning: Do not operate the sideburner option simultaneously with the rotisserie. The sideburner will melt the rotisserie handle.

Secure meat firmly to the spit rod with meat holders. (It may be necessary to tie fowl and rolled roasts to retain their shape for even rotation.) To ensure proper rotation, it is important to adequately balance and fasten the meat or fowl onto the spit rod.

Before heating the grill, rotate the spit rod and meat manually a few times. If out of balance, attach the counterbalance assembly to the spit to even out the weight and rotate again.

During cooking, adjust the meat holders if the meat shrinks and pulls away from the spit rod. Use gloves and caution to prevent burns.

2

Prepare the grill for rotisserie cooking by removing the cooking grids. Be certain that the rotisserie brackets and motor are securely in place, then light the burner and close the grill lid for preheating.

Important: The side shelf will need to be removed to accomodate the motor on Broilmaster® P5 grills.

3

After preheating (350 to 400), place the loaded spit rod into position. Start the rotisserie motor and make certain the food is properly balanced. Close the grill lid and lower the heat as required by changing the valve knob setting or by opening the grill lid to any of the adjustable secondary heat regulator positions, allowing heat to escape from inside the grill.

Note: Beef and pork roasts and certain types of fowl will release a considerable amount of fat and juice in the process of cooking and are therefore "self-basting". Lean meat and chicken will taste better if basted occasionally with melted butter, margarine, salad oil, barbeque sauce or a sauce of your own preference.

The exact degree of "doneness" can be determined by the use of a meat thermometer.

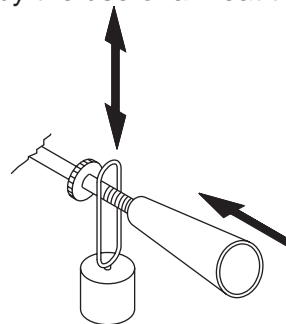

**BM ROTISSERIE
COUNTERWEIGHT**
SCREW HANDLE ONTO ROD
UNTIL SNUG AGAINST
COUNTER BALANCE.
COUNTER BALANCE CAN BE
ADJUSTED VERTICALLY FOR
BEST WEIGHT DISTRIBUTION.

FOODS RECOMMENDED FOR THE ROTISSERIE AND COOKING TIMES

These times are approximate and depend upon cooking temperature, thickness of cuts and the degree of "doneness" desired.

TYPE OF MEAT	TIME
Whole Chickens (2~ - 4 lbs.)	60 minutes
Pork loin roasts (per lb.)	30 minutes
Whole Boneless ham (per lb.)	30 minutes
Rolled Beef Roast (per lb.)	30 minutes
Beef rump roast (per lb.)	30 minutes
Whole Turkey (per lb.)	20 minutes
Country-style or back ribs of pork	40-60 minutes
Shoulder or rack of lamb (per lb.)	30 minutes
Large fish (trout, salmon)(per lb.)	10-20 minutes
Large whole lobsters	15-20 minutes

All repair part orders should be placed through your local Broilmaster® dealer. To locate a dealer in your area, contact Broilmaster Customer Service at (256) 740-5223. To ensure prompt and accurate service, please provide the following information when placing a repair part order: Model number of your Rotisserie, Part Name, Part Number, and Quantity of parts needed.

KEY NO.	PART NAME	QTY. REQ'D	REPAIR PART NO.
1	ROTISSERIE MOTOR	1	076848
2	10-24 X 1/2 SCREW	2	*
3	MOTOR BRACKET	1	076840
4	10-24 WING NUT	2	*
5	MEAT HOLDER	2	076850
6	LOCATOR SLEEVE	1	076849
7	SPIT ROD	1	076851
8	HANDLE AND THUMBNUIT	1	076854
9	COUNTER BALANCE ASSY	1	076852
* MAY BE PURCHASED LOCALLY			

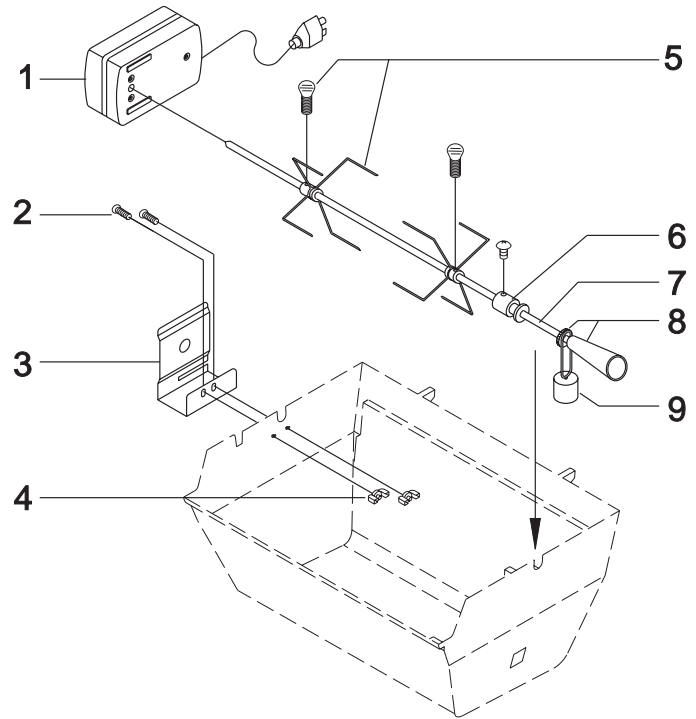

BROILMASTER®

A DIVISION OF **EMPIRE COMFORT SYSTEMS, INC.**
 918 FREEBURG AVE. • BELLEVILLE, ILLINOIS 62220
 PHONE: 618-233-7420 FAX: 618-233-7097

RETAIN OWNER'S MANUAL FOR FUTURE REFERENCE.