

EMPIRE

COMFORT SYSTEMS

INSTALLATION INSTRUCTIONS AND OWNER'S MANUAL

Outdoor Gas Fireplace

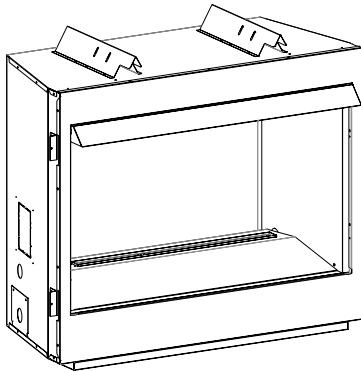

OUTDOOR GAS FIREPLACE MODELS

OLP36FP72S(N,P)-2
OLP42FP72S(N,P)-2



DANGER



CARBON MONOXIDE HAZARD

This appliance can produce carbon monoxide which has no odor.

Using it in an enclosed space can kill you.

Never use this appliance in an enclosed space such as a camper, tent, car or home.

Installer: Leave this manual with the appliance.
Consumer: Retain this manual for future reference.

This appliance is only for use with the type of gas indicated on the rating plate. This appliance is not convertible for use with other gases.

- Do not store or use gasoline or other flammable vapors and liquids in the vicinity of this or any other appliance.
- Installation and service must be performed by a qualified installer, service agency or the gas supplier.

WARNING

If the information in these instructions are not followed exactly, a fire or explosion may result causing property damage, personal injury or loss of life.

WARNING

Improper installation, adjustment, alteration, service or maintenance can cause injury or property damage. Read the installation, operating and maintenance instructions thoroughly before installing or servicing this equipment.

WARNING

For Outdoor Use Only.

WARNING

If not installed, operated and maintained in accordance with the manufacturer's instructions, this product could expose you to substances in fuel or from fuel combustion which can cause death or serious illness.

WARNING

If you smell gas:

1. Shut off gas to the appliance.
2. Extinguish any open flame.
3. If odor continues, keep away from the appliance and immediately call your gas supplier or fire department.

WARNING

Do not store or use gasoline or other flammable vapors and liquids in the vicinity of this or any other appliance.

An LP-cylinder not connected for use shall not be stored in the vicinity of this or any other appliance.

TABLE OF CONTENTS

SECTION	PAGE
Important Safety Information.....	3
Safety Information for Users of LP-Gas	4
Introduction	5-6
Specifications	7
Gas Supply.....	7
Clearances	8
Combustible Materials.....	8
Fireplace Dimensions.....	9
Planning Installation	10-11
Fireplace Framing and Installation	12-13
Gas Line Connection.....	13
Operation Instructions / Flame Appearance.....	14
OLP(36,42)FP72 Lighting Instructions	15
Main Burner Flame Characteristics.....	16
Wiring.....	16
Remote Control Installation & Operation.....	17
Maintenance.....	18
Troubleshooting.....	19
Master Parts Distributor List.....	20
How To Order Repair Parts	20
Parts List	20
Parts View	21
Appliance Service History	22
Warranty Terms.....	23



IMPORTANT SAFETY INFORMATION

- **Installer:** Please leave these instructions with the owner for future reference
- This unit complies with ANSI Z21.97/CSA 2.41 and CSA 4.96 U.S. for Outdoor Gas Fireplaces.
- Children and adults should be alerted to the hazard of high surface temperature and should stay away to avoid burns or clothing ignition.
- Young children should be carefully supervised when they are in the same area with the appliance.
- Clothing or other flammable materials should not be hung from the appliance, or placed on or near the appliance.
- Installation and repair should be done by a **QUALIFIED SERVICE PERSON**. This appliance should be inspected before use and at least annually by a professional service person. More frequent cleaning may be required due to insects, pollen build up, dust, etc. It is imperative that the control compartments, burners, and circulating air passageways of the appliance be kept clean.
- Do not place trash, logs, or other articles on the log set during operation.
- During manufacturing, fabricating and shipping, various components of this appliance are treated with certain oils, films or bonding agents. These agents are not harmful, but may produce annoying smoke and smells as they are burned off during initial operation of the appliance. This is a normal temporary occurrence.
- **WARNING:** Keep appliance area clear and free from combustible materials, gasoline and other flammable vapors and liquids.
- **WARNING:** Any modification to this gas log set or to controls can be dangerous. Improper installation or use of the gas log set can cause serious injury or death from fire, burns, explosion or carbon monoxide poisoning.
- Follow all local codes regarding installation, combustion and ventilation air or in the absence of local codes follow the National Fuel Gas Code ANSI Z223.1 (US installation), or CAN/CGA-B149, installation Code (Canada installation).
- Do not operate this log set with glass doors in the closed position. A fireplace screen must be in place when the log set is burning.
- Inspect the hose before each use of the appliance.
 - The hose assembly must be replaced prior to the appliance being into operation if there is evidence of excessive abrasion or wear, or if the hose is damaged.
- Inspect the burner at least once a year.

DO NOT OPERATE THIS GAS LOG SET WITH GLASS DOORS CLOSED.

▲ DANGER: Indicates a hazardous situation which, if not avoided, will result in death or serious injury.

▲ WARNING: Indicates a hazardous situation which, if not avoided, could result in death or serious injury.

▲ CAUTION: Indicates a hazardous situation which, if not avoided, could result in minor or moderate injury.

NOTICE: Addresses practices not related to personal injury.

- Children and adults should be alerted to the hazards of high surface temperatures and should stay away to avoid burns or clothing ignition.
- Young children should be carefully supervised when they are in the same area as the appliance.
- Clothing or other flammable material should not be placed on or near the appliance.
- Do not place trash or other articles on the log set during operation.
- During manufacturing, fabricating and shipping, various components of this appliance are treated with certain oils, films or bonding agents. These bonding agents are not harmful but may produce annoying smoke and smells as they are burned off during initial operation of the appliance. This is a normal temporary occurrence.
- Keep burner and control compartment clean.
- Installation and repair should be done by a **QUALIFIED SERVICE PERSON**. The appliance should be inspected before use and at least annually by a qualified service person. More frequent cleaning may be required due to excessive lint from carpeting, bedding materials, etc. It is imperative that control compartments, burners and circulating air passageways of the appliance be kept clean.
- **DO** keep the appliance area clear and free from combustible material, gasoline and other flammable vapors and liquids.
- A yearly examination and cleaning of the venting system of the solid-fuel burning fireplace must be performed by a qualified agency.
- **DO** make a periodic visual check of pilot and burners. Clean and replace damaged parts.
- **DO NOT** use this appliance if any part has been under water. Immediately call a qualified service technician to inspect the appliance and to replace any part of the control system and any gas control which has been under water.

SAFETY INFORMATION FOR USERS OF LP-GAS

Propane (LP-Gas) is a flammable gas which can cause fires and explosions. In its natural state, propane is odorless and colorless. You may not know all the following safety precautions which can protect both you and your family from an accident. Read them carefully now, then review them point by point with the members of your household. Someday when there may not be a minute to lose, everyone's safety will depend on knowing exactly what to do. If, after reading the following information, you feel you still need more information, please contact your gas supplier.

LP-GAS WARNING ODOR

If a gas leak happens, you should be able to smell the gas because of the odorant put in the LP-Gas. That's your signal to go into immediate action!

- Do not operate electric switches, light matches, use your phone. Do not do anything that could ignite the gas.
- Get everyone out of the building, vehicle, trailer, or area. Do that IMMEDIATELY.
- Close all gas tank or cylinder supply valves.
- LP-Gas is heavier than air and may settle in low areas such as basements. When you have reason to suspect a gas leak, keep out of basements and other low areas. Stay out until firefighters declare them to be safe.
- Use your neighbor's phone and call a trained LP-Gas service person and the fire department. Even though you may not continue to smell gas, do not turn on the gas again. Do not re-enter the building, vehicle, trailer, or area.
- **Finally**, let the service man and firefighters check for escaped gas. Have them air out the area before you return. Properly trained LP-Gas service people should repair the leak, then check and relight the gas appliance for you.

NO ODOR DETECTED - ODOR FADE

Some people cannot smell well. Some people cannot smell the odor of the chemical put into the gas. You must find out if you can smell the odorant in propane. Smoking can decrease your ability to smell. Being around an odor for a time can affect your sensitivity or ability to detect that odor. Sometimes other odors in the area mask the gas odor. People may not smell the gas odor or their minds are on something else. Thinking about smelling a gas odor can make it easier to smell.

The odorant in LP-gas is colorless, and it can fade under some circumstances. For example, if there is an underground leak, the movement of the gas through soil can filter the odorant. Odorants in LP-Gas also are subject to oxidation. This fading can occur if there is rust inside the storage tank or in iron gas pipes.

The odorant in escaped gas can adsorb or absorb onto or into walls, masonry and other materials and fabrics in a room. That will take some of the odorant out of the gas, reducing its odor intensity.

LP-Gas may stratify in a closed area, and the odor intensity could vary at different levels. Since it is heavier than air, there may be more odor at lower levels. Always be sensitive to the slightest gas odor. If you detect any odor, treat it as a serious leak. Immediately go into action as instructed earlier.

SOME POINTS TO REMEMBER

- Learn to recognize the odor of LP-gas. Your local LP-Gas Dealer can give you a "Scratch and Sniff" pamphlet. Use it to find out what the propane odor smells like. If you suspect that your LP-Gas has a weak or abnormal odor, call your LP-Gas Dealer.
- If you are not qualified, do not light pilot lights, perform service, or make adjustments to appliances on the LP-Gas system. If you are qualified, consciously think about the odor of LP-Gas prior to and while lighting pilot lights or performing service or making adjustments.
- Sometimes a basement or a closed-up house has a musty smell that can cover up the LP-Gas odor. Do not try to light pilot lights, perform service, or make adjustments in an area where the conditions are such that you may not detect the odor if there has been a leak of LP-Gas.
- Odor fade, due to oxidation by rust or adsorption on walls of new cylinders and tanks, is possible. Therefore, people should be particularly alert and careful when new tanks or cylinders are placed in service. Odor fade can occur in new tanks, or reinstalled old tanks, if they are filled and allowed to set too long before refilling. Cylinders and tanks which have been out of service for a time may develop internal rust which will cause odor fade. If such conditions are suspected to exist, a periodic sniff test of the gas is advisable. **If you have any question about the gas odor, call your LP-gas dealer. A periodic sniff test of the LP-gas is a good safety measure under any condition.**
- If, at any time, you do not smell the LP-Gas odorant and you think you should, assume you have a leak. Then take the same immediate action recommended above for the occasion when you do detect the odorized LP-Gas.
- If you experience a complete "gas out," (the container is under no vapor pressure), turn the tank valve off immediately. If the container valve is left on, the container may draw in some air through openings such as pilot light orifices. If this occurs, some new internal rusting could occur. If the valve is left open, then treat the container as a new tank. Always be sure your container is under vapor pressure by turning it off at the container before it goes completely empty or having it refilled before it is completely empty.

INTRODUCTION

Instructions to Installer

1. Installer must leave instruction manual with owner after installation.
2. Installer must have owner fill out and mail warranty card supplied with this fireplace.
3. Installer should show owner how to start and operate unvented room heater.

Always consult your local Building Department regarding regulations, codes or ordinances which apply to the installation of an unvented room heater.

*Aftermarket: Completion of sale, not for purpose of resale, from the manufacturer.

This appliance is only for use with the type of gas indicated on the rating plate. This appliance is not convertible for use with other gases.

WARNING

ANY CHANGE TO THIS APPLIANCE OR ITS CONTROLS CAN BE DANGEROUS.

Improper installation or use of the appliance can cause serious injury or death from fire, burns, explosion or carbon monoxide poisoning.

This series is design certified in accordance with American National Standard Z21.97.1/CSA 2.41 by the Underwriters Laboratories as an Outdoor Gas Fireplace and should be installed according to these instructions.

Any alteration of the original design, installed other than as shown in these instructions or use with a type of gas not shown on the rating plate is the responsibility of the person and company making the change.

750 Millivolt System

When you ignite the pilot, the thermocouple produces millivolts (electrical current) which energizes the magnet in the gas valve. After 30 seconds to 1 minute time period you can release the gas control knob and the pilot will stay ON. Allow your pilot flame to operate an additional one (1) to two (2) minutes before you turn the gas control knob from the PILOT position to the ON position. This time period allows the millivolts (electrical energy) to build-up to a sufficient level allowing the gas control to operate properly.

Important

All correspondence should refer to complete Model Number, Serial Number and type of gas.

Moisture Resistance

This outdoor fireplace will shed moderate amounts of water, but is not waterproof. Water and condensing water vapor may enter the chase under certain conditions.

The fireplace will not perform as an exterior wall. Moisture penetration must be considered for construction that places the fireplace in structure walls or on moisture sensitive surfaces.

When installed on exterior walls: Empire Comfort Systems recommends the fireplace chase be constructed outside the structure's weather envelope. Where the platform meets the wall, use a flashing detail similar to that required for attached decks. Chase platforms, including hearths should slope away from the structure at 1/4 in per foot. The fireplace can be shimmed level.

When installed on surfaces where water may collect or cause damage: Empire Comfort Systems recommends a slope of 1/8 in to 1/4 in per foot towards the drain port suggested. The fireplace can be shimmed level.

Hearths should slope away from the front of the fireplace and chase

at 1/8 in to 1/4 in per foot. Metal safety strips must be on top of any combustible hearth materials used for moisture management. When purchasing a firebox or fireplace we recommend you also buy a weather cover or glass door accessory to protect the unit from moisture. Never install a burner where moisture cannot drain off easily. We recommend a weather barrier - such as a cover or bifold glass doors - to protect the burner from moisture.

Screened Porch Installation

The fireplace may be installed safely and is design certified by UL to be installed in a screen porch with the following guidelines.

Minimum Porch Area	96 sq. feet (9 sq m)
Minimum Ceiling Height	92" (234 cm)

(See Page 10)

Installation on Rugs and Tile

If this appliance is installed directly on carpeting, tile or other combustible material other than wood flooring the appliance shall be installed on a metal or wood panel extending the full width and depth of the appliance.

The base referred to above does not mean the fire-proof base as used on wood stoves. The protection is for rugs that are extremely thick and light colored tile.

Solid-fuels shall not be burned in a masonry or *UL 127* factory-built fireplace in which an unvented room heater is installed.

Qualified Installing Agency

Installation and replacement of gas piping, gas utilization equipment or accessories and repair and servicing of equipment shall be performed only by a qualified agency. The term "qualified agency" means any individual, firm, corporation or company which either in person or through a representative is engaged in and is responsible for (a) the installation or replacement of gas piping or (b) the connection, installation, repair or servicing of equipment, who is experienced in such work, familiar with all precautions required and has complied with all the requirements of the authority having jurisdiction.

State of Massachusetts: The installation must be made by a licensed plumber or gas fitter in the Commonwealth of Massachusetts.

The installation must conform with local codes or, in the absence of local codes, with the National Fuel Gas Code, ANSI Z223.1.*

*Available from the American National Standards Institute, Inc. 1430 Broadway, New York, N.Y. 10018.

High Altitudes

For altitudes/elevations above 2,000 feet (610m), ratings should be reduced at the rate of 4 percent for each 1,000 feet (305m) above sea level. Contact the manufacturer or your gas company before changing spud/orifice size.

Well Head Gas Installations

Some natural gas utilities use "well head" gas. This may affect the Btu output of the unit. Contact the gas company for the heating value. Contact the manufacturer or your gas company before changing spud/orifice size.

WARNING: This appliance is equipped for (natural gas or propane) gas. Field conversion is not permitted.

INTRODUCTION

- When the appliance is connected to a fixed piping system, the installation must conform with local codes, or in the absence of local codes with the *National Fuel Gas Code, ANSI Z223.1/NFPA 54*, or *International Fuel Gas Code*.
- When installed, the appliance must be electrically grounded in accordance with local codes, or in the absence of local codes with the *National Electrical Code, ANSI/NFPA 70*, if applicable.
- Solid fuels shall not be burned in this appliance.
- The maximum gas inlet supply pressure is 13" for LP and 10.5" for NAT.
- For appliances for fixed fuel piping system and equipped with an appliance gas pressure regulator, the required manifold pressure in inches water column: 10" for LP and 3.5" NAT.
- For appliances for fixed fuel piping system and equipped with an appliance gas pressure regulator, the appliance and its individual shutoff valve must be disconnected from the gas supply piping system during any pressure testing of that system at test pressures in excess of 1/2 psi (3.5 kPa). The appliance must be isolated from the gas supply piping system by closing its individual manual shutoff valve during any pressure testing of the gas supply piping system at test pressures equal to or less than 1/2 psi (3.5 kPa).

For an appliance designed for use with a non-disposable self-contained LP-gas supply system:

- Propane cylinders may be acceptable for use with the appliance provided they are compatible with the appliance retention means.
- LP-gas supply cylinder must be constructed and marked in accordance with the *U.S. Department of Transportation (D.O.T.) Specifications for LP-Gas Cylinders*, or the *Standard for Cylinders, Spheres and Tubes for Transportation of Dangerous Goods and Commission, CAN/CSA-B339* as applicable.
- LP-gas supply cylinders between 4 and 40 pounds must have an overfill prevention device.
- LP-gas supply cylinder must have a connection device compatible with the connection of the appliance.
- If the appliance is equipped with a CGA No. 600 Cylinder Connection Device, the cylinder must be disconnected when the appliance is not in use.
- If appliance is to be permanently connected to a gas piping system from a remote supply tank, installation must be in accordance with local codes or, in the absence of local codes, with the *National Fuel Gas Codes ANSI Z223.1/NFPA 54*.

Enclosures for LP-gas supply cylinders shall be ventilated by openings at the level of the cylinder valve and at floor level. The effectiveness of the opening(s) for purposes of ventilation shall be determined with the LP-gas supply cylinder(s) in place. This shall be accomplished by one of the following.

- a. One side of the enclosure shall be completely open; or
- b. For an enclosure having four sides, a top and a bottom:
 1. At least two ventilation openings at cylinder valve level shall be provided in the side wall, equally sized, spaced at 180 degrees (3.14rad), and unobstructed. Each opening shall have a total free area of not less than 1/2 square inch per pound (2.3 sq. cm/kg) of stored fuel capacity and not less than a total free area of 10 square inches (64.5 sq. cm).
 2. Ventilation opening(s) shall be provided at floor level and shall have a total free area of not less than 1/2 square inch per pound (3.2 sq. cm/kg) of stored fuel capacity and not less than a total free area of 10 square inches (64.5 sq. cm). If ventilation openings at floor level are in a side all, there shall be at least two openings. The bottom of the openings shall be at floor level and the upper edge no more than 5 inches (127 mm) above the floor. The openings shall be equally sized, spaced at 180 degrees (3.14 rad) and unobstructed.
 3. Every opening shall have minimum dimensions so as to permit the entrance of a 1/8 inch (3.2 mm) diameter rod.

- Cylinder valves shall be readily accessible for hand operation. A door on the enclosure to gain access to the cylinder valves is acceptable, provided it is non-locking and can be opened without the use of tools.
- There shall be a minimum clearance of 2 inches (51 mm) between the lower surface of the floor of the LP-gas supply cylinder enclosure and the ground.
- The design of the appliance shall be such that (1) the LP-gas supply cylinder(s) can be connected, disconnected and the connections inspected and tested outside the cylinder enclosure; and (2) those connections which could be disturbed when installing the cylinder(s) in the enclosure can be leak tested inside the enclosure;

Cleaning Instructions

This appliance is built using mostly high-grade stainless steel to resist rust-through. In outdoor applications, all stainless steel will develop a dull patina and, depending on the local environment and on the materials used in the installation, may develop some surface oxidation (rust). This does not affect the performance of the fireplace, and does not require any action to correct. If you prefer keeping your fireplace front looking factory-fresh, clean it as required with stainless steel cleaner.

When installation application includes highly acidic applications such as mortar or stone etching, do not remove the protective PVC film from the stainless steel until after this application is complete. Once the film has been removed we recommend that the appliance be cleaned with a stainless steel cleaner immediately.

Please note that areas where the film has been formed (corners, hems, etc.) may require extra cleaning due to the properties of the film. Ensure that all protective film has been removed from the fireplace prior to burning the appliance.

SPECIFICATIONS

Model	OLP36FP	OLP42FP
Input Maximum	36,000	40,000
Minimum	28,000 LP / 27,000 NAT	28,000 LP / 28,000 NAT
Orifice	P245 #50 LP / P209 #31 NAT	P265 #49 LP / P209 #31 NAT
Air Shutter Opening	LP Full Open / Nat 1/8" Open	LP Full Open / Nat. 1/8" Open
Accessories		
BD36SS	36" Bifold Glass Door - Stainless Steel	
BD42SS	42" Bifold Glass Door - Stainless Steel	
DT36SS	36" Drain Tray - Stainless Steel	
DT42SS	42" Drain Tray - Stainless Steel	
WD36SS	36" Weather Door - Stainless Steel	
WD42SS	42" Weather Door - Stainless Steel	

GAS SUPPLY

Check all local codes for requirements, especially for the size and type of gas supply line required.

Recommended Gas Pipe Diameter				
Pipe Length	Schedule 40 Pipe Inside Diameter		Tubing, Type L Outside Diameter	
	Nat.	L.P.	Nat.	L.P.
0-10 feet 0-3 meters	1/2" 12.7mm	3/8" 9.5mm	1/2" 12.7mm	3/8" 9.5mm
10-40 feet 4-12 meters	1/2" 12.7mm	1/2" 12.7mm	5/8" 15.9mm	1/2" 12.7mm
40-100 feet 13-30 meters	1/2" 12.7mm	1/2" 12.7mm	3/4" 19mm	1/2" 12.7mm
100-150 feet 31-46 meters	3/4" 19mm	1/2" 12.7mm	7/8" 22.2mm	3/4" 19mm

Note: Never use plastic pipe. Check to confirm whether your local codes allow copper tubing or galvanized.

Note: Since some municipalities have additional local codes, it is always best to consult your local authority and installation code.

Note: Be sure to install gas line cover to appliance prior to completing gas line connection.

Installing a New Main Gas Cock

Each appliance should have its own manual gas cock.

A manual main gas cock should be located in the vicinity of the unit. Where none exists, or where its size or location is not adequate, contact your local authorized installer for installation or relocation.

Compounds used on threaded joints of gas piping shall be resistant to the action of liquefied petroleum gases. The gas lines must be checked for leaks by the installer. This should be done with a soap solution watching for bubbles on all exposed connections, and if unexposed, a pressure test should be made.

Never use an exposed flame to check for leaks. Appliance must be disconnected from piping at inlet of control valve and pipe capped or plugged for pressure test. Never pressure test with appliance connected; control valve will sustain damage!

A gas valve and ground joint union should be installed in the gas line upstream of the gas control to aid in servicing. It is required by the National Fuel Gas Code that a drip line be installed near the gas inlet. This should consist of a vertical length of pipe tee connected into the gas line that is capped on the bottom in which condensation and foreign particles may collect.

The use of the following gas connectors is recommended:

- ANS Z21.24 Appliance Connectors of Corrugated Metal Tubing and Fittings
- ANS Z21.45 Assembled Flexible Appliance Connectors of Other Than All-Metal Construction

The above connectors may be used if acceptable by the authority having jurisdiction. The state of Massachusetts requires that a flexible appliance connector cannot exceed three feet in length.

FLEXIBLE GAS LINE CONNECTION

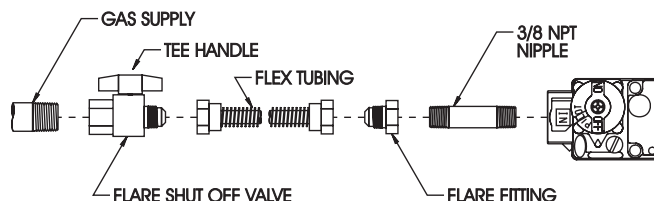

RIGID GAS LINE CONNECTION

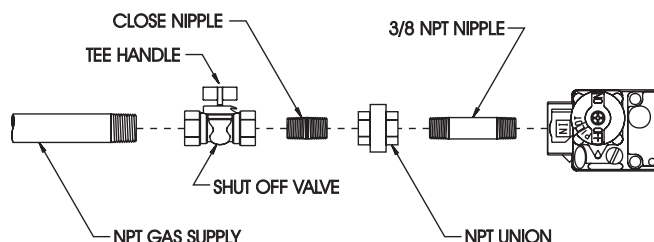

Figure 1

CLEARANCES

Minimum Wall and Ceiling Clearances (Figure 2)

Sidewall and Back Clearances: The clearance from the inside of the fireplace to any combustible wall should not be less than 2".

Ceiling Clearances: The ceiling height should not be less than 36" from the top of the hood.

Mantel Clearances: Ventless fireplace models must use the hood supplied with the fireplace. If a combustible mantel is installed, it must meet the clearance requirements detailed in Figure 2..

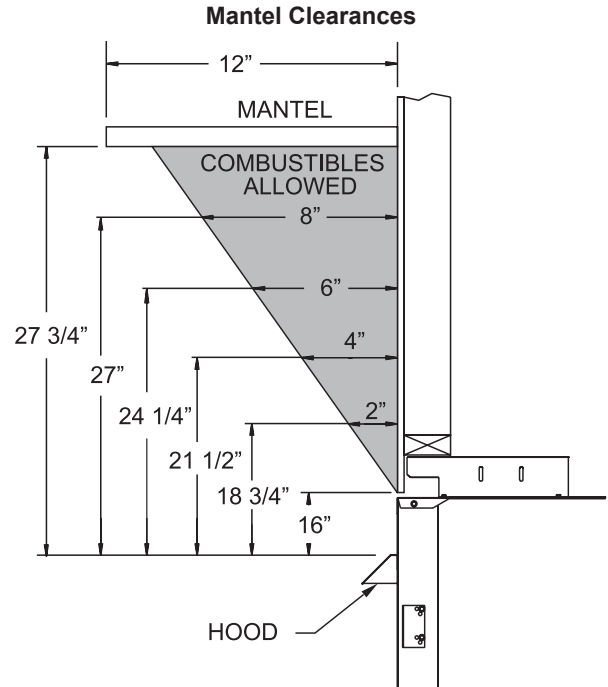

Figure 2

COMBUSTIBLE MATERIALS

Do not attach combustible material to the mantel of your fireplace. This is a fire hazard.

No greeting cards, stockings or ornamentation of any type should be placed on or attached to the fireplace. This is a heating appliance. The flow of heat can ignite combustibles.

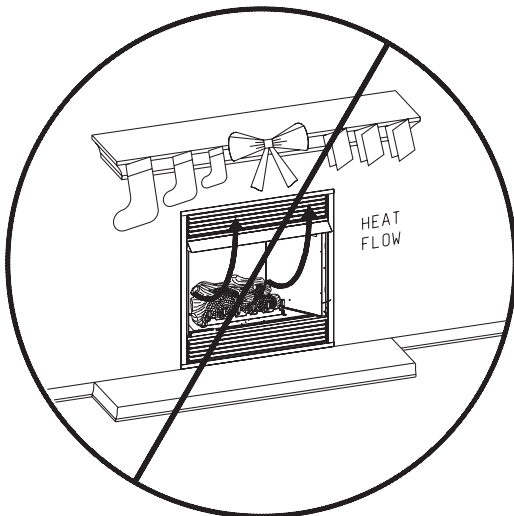

Figure 3

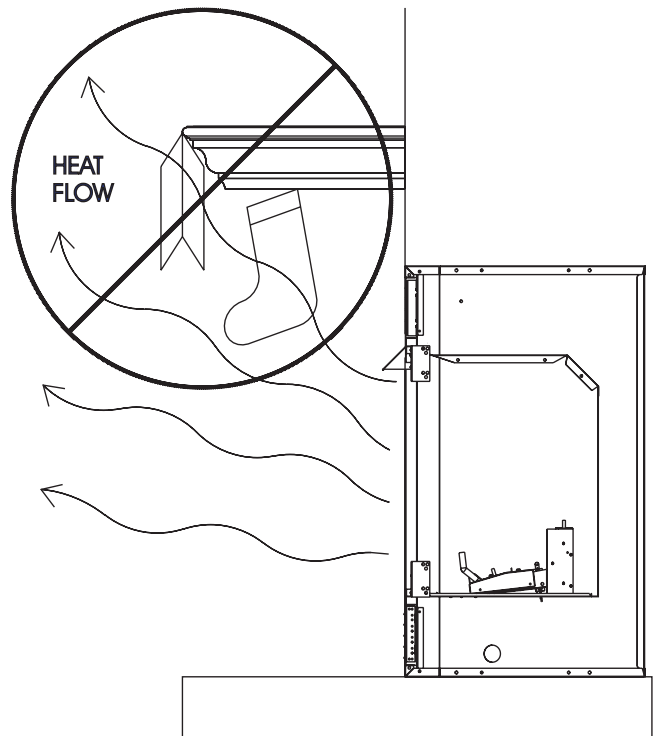
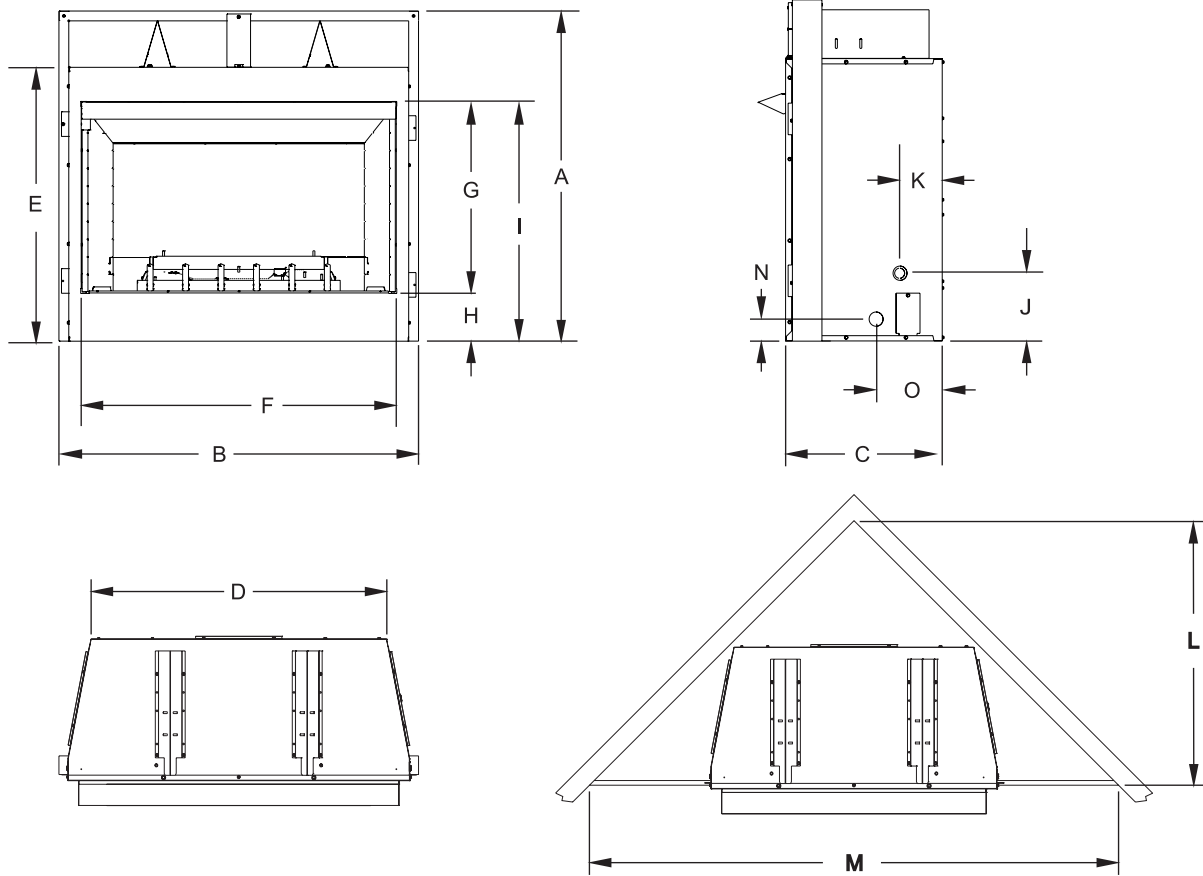

Figure 4

FIREPLACE DIMENSIONS



DIMENSIONS (in inches)		
REFERENCE LETTER	OLP36FP	OLP42FP
A	42-1/8	42-1/8
B	41-3/4	45-3/4
C	19-1/4	19-1/4
D	32-1/4	36-1/4
E	34-7/8	34-7/8
F	36	40
G	24	24
H	6-3/8	6-3/8
I	30-3/8	30-3/8
J	8-3/8	8-3/8
K	5-1/4	5-1/4
L	37-5/8	39-5/8
M	75-3/8	79-1/4
N	2-11/16	2-11/16
O	8-1/8	8-1/8

PLANNING INSTALLATION

In planning the installation for the fireplace, it is necessary to determine where the unit is to be installed and whether optional accessories are desired. Gas supply piping should also be planned at this time.

The fireplace can be mounted on any of these surfaces:

1. A flat hard combustible or non-combustible surface.
2. A raised platform of non-combustible material.
3. Four (4) corners of the fireplace so contact is made on all four perimeter edges on the bottom of the unit.

(Example: Four (4) concrete masonry blocks.)

If the fireplace is installed directly on carpeting, tile or other combustible material other than wood flooring, it should be installed on a metal or wood panel extending the full width and depth of the unit.

At this point, you should have decided what components to include in your installation, and where the fireplace is to be located. If this has not been done, stop and consult your dealer for assistance with this planning.

This fireplace is intended for installation on an outdoor patio or in your yard. This fireplace shall be used only outdoors in a well ventilated space and shall NOT be used in a building, garage, or other enclosed area.

It is recommended that this fireplace be installed in a "sheltered" area. Direct wind will cause an erratic flame and possible pilot or main burner outage. This erratic flame could also lead to excessive black soot. These issues are nuisance issues rather than a safety issues.

Typical installation may include covered patio, screened porch, gazebo or an outside wall of a house.

- Minimum porch area – 96 square feet
- Minimum ceiling height – 92 inches

Television Considerations

Installing a television above an appliance has become increasingly popular; however, the area above any appliance gets hot and most TV manufacturers recommend against placing their products near a heat source.

If you install a television above this appliance, Empire Comfort Systems accepts no responsibility for damage or injuries. Follow the television manufacturer's installation instructions, including any recommendations regarding proximity to heat sources.

If you have a TV above your appliance, turn off the appliance and let it cool completely before servicing or touching any buttons on the TV.

Outdoor Fireplace Enclosure Requirements

Do not install appliance until all necessary provisions are made for combustion and ventilation air. Consult the written instructions provided with the appliance for information concerning combustion and ventilation air. In the absence of instructions, refer to the National Fuel Gas Code, ANSI Z223.1/NFPA 54, Air for Combustion and Ventilation, or applicable local codes.

NOTICE: This fireplace is NOT equipped with an ODS pilot.

Installation must conform with one of the following conditions:

- With walls on all sides, but with no overhead cover;
- Within a partial enclosure which includes an overhead cover and no more than two side walls. These side walls may be parallel, as in a breezeway or at right angles to each side; or
- Within a partial enclosure which includes an overhead cover and three sidewalls, as long as 30% or more of the horizontal periphery of the enclosures is permanently open.

WARNING

Improper installation, adjustment, alteration, service or maintenance can cause property damage, personal injury or loss of life. Installation and service must be performed by a qualified installer, service agency or the gas supplier.

Clearances

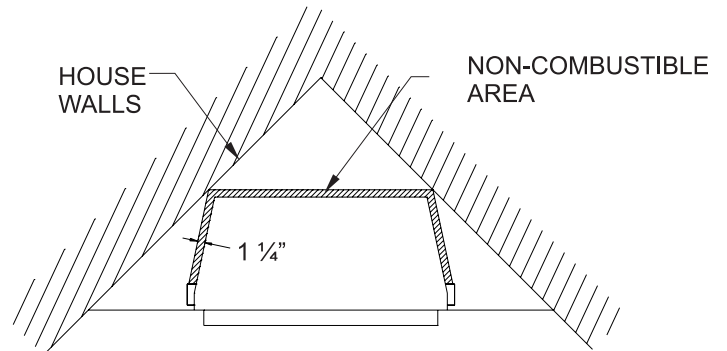

Figure 5

The front of the fireplace may have 0" clearance as far back as 1/2" where studs are to be placed.

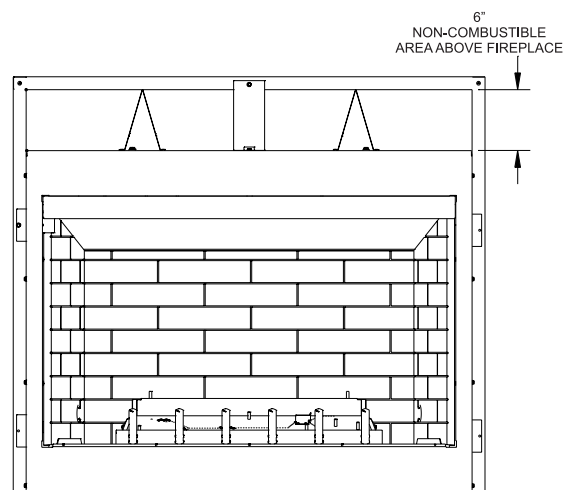

Figure 6

PLANNING INSTALLATION

Installing the Hood

A stainless steel hood is furnished with each outdoor fireplace. The hood **MUST** be installed before the fireplace is used. Failure to do so may create a possible fire hazard.

Finishing

Hearth extensions are recommended, not a requirement for these gas fireplaces.

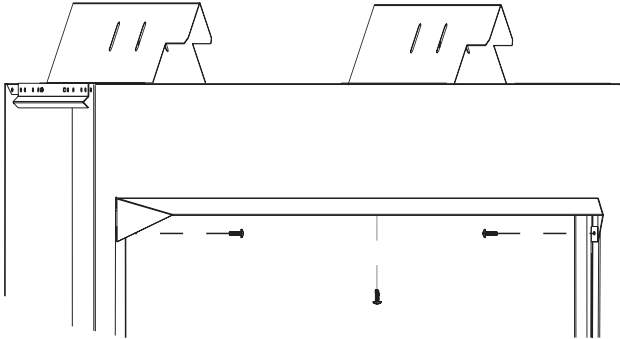

Figure 7

Cleaning Instructions

This appliance is built using mostly high-grade stainless steel to resist rust-through. In outdoor applications, all stainless steel will develop a dull patina and, depending on the local environment and on the materials used in the installation, may develop some surface oxidation (rust). This does not affect the performance of the fireplace, and does not require any action to correct. If you prefer keeping your fireplace front looking factory-fresh, clean it as required with stainless steel cleaner.

When installation application includes highly acidic applications such as mortar or stone etching, do not remove the protective PVC film from the stainless steel until after this application is complete. Once the film has been removed we recommend that the appliance be cleaned with a stainless steel cleaner immediately.

Please note that areas where the film has been formed (corners, hems, etc.) may require extra cleaning due to the properties of the film. Ensure that all protective film has been removed from the fireplace prior to burning the appliance.

FIREPLACE FRAMING AND INSTALLATION

Locate the three metal framing studs:

	SIDE	TOP
OLP36FP	Two - 42" Stud	One - 41-5/8" Top Stud
OLP42FP	Two - 42" Stud	One - 45-5/8" Top Stud

1. Secure the metal studs to the frame using six #10 pan-head screws as shown in Figure 8. The channel of the studs should face as shown in Figure 8.

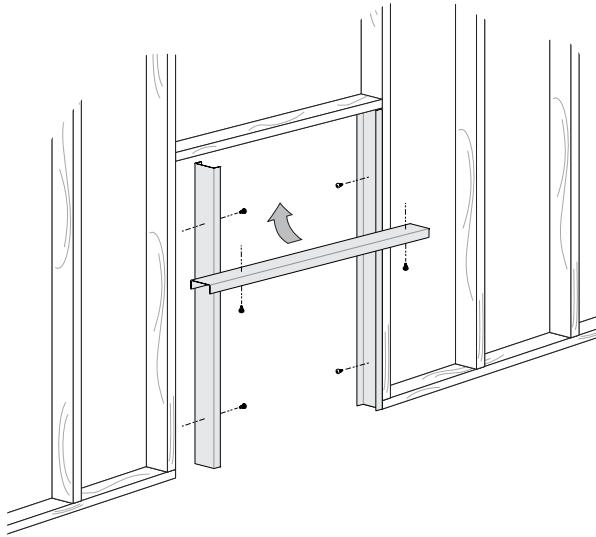

Figure 8

2. Install flanges on side of fireplace as shown using holes on side of fireplace. See Figure 9. The middle pair of holes is for the 1/2 inch non-combustible board provided with the unit.

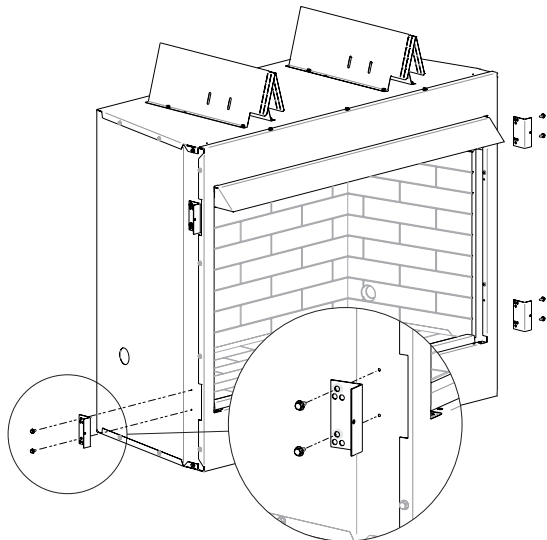

Figure 9

3. Locate the middle bracket. Loosen the screw in the middle top of the fireplace. Slide the bracket under the screw as shown in Figure 11. Tighten the hex-head screws on the fireplace secure a pan-head screw through the middle bracket and into the top stud.
4. Slide the fireplace into position inside the metal studs. Secure the fireplace to the metal studs with four #10 pan-head screws as shown in Figure 10.
Note: Ensure that the gas shut-off valve is accessible.

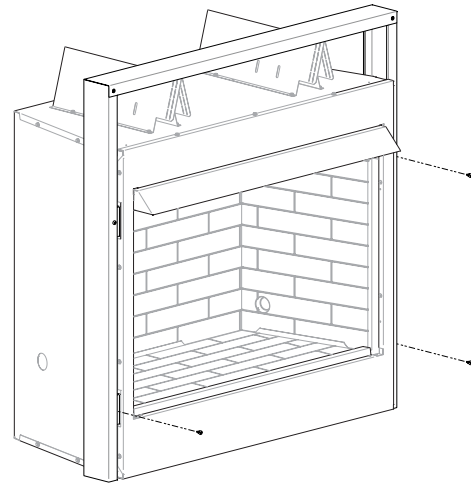

Figure 10

5. Connect the gas line to the unit and check for leaks with a soapy water solution.
Note: Ensure that the gas shut-off valve is accessible.
6. Locate the two non-combustible boards and place them above the fireplace as shown in Figure 12. Attach the non-combustible board to the studs with six 10-16 flathead screws.

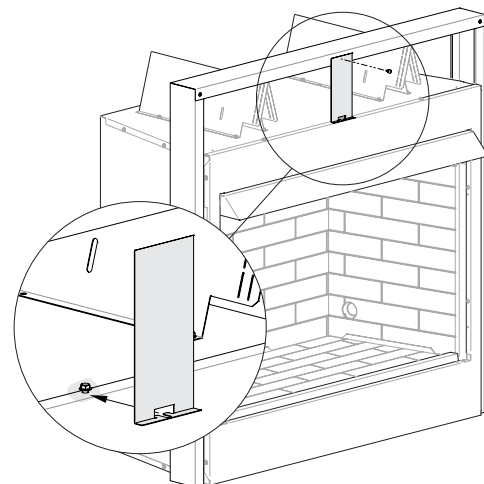

Figure 11

7. Secure the non-combustible board to the middle bracket using two 10-16 flathead screws as shown in Figure 12.

FIREPLACE FRAMING AND INSTALLATION

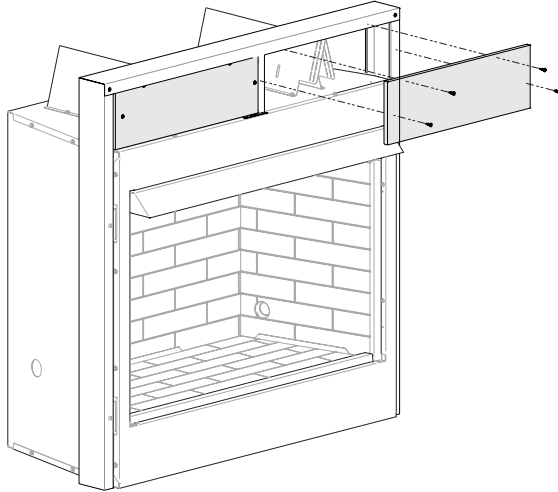

Figure 12

Alternate Framing and Installation Method

1. Install flanges on side of fireplace as shown using holes on side of firebox. See Figure 9. The middle pair of holes is for the 1/2 inch non-combustible board provided with the unit.
2. Connect the side framing studs to the top stud as shown in Figure 13. The channel of the studs should face inward.

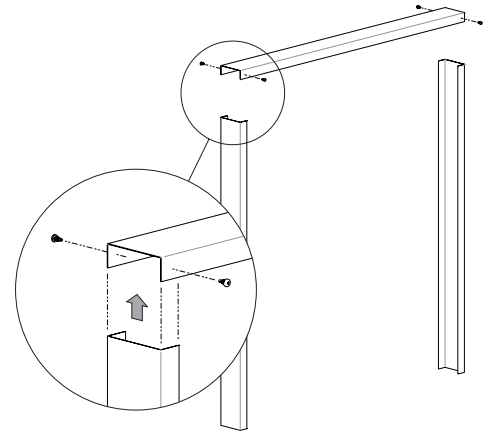

Figure 13

3. Connect the framing studs to the flanges using four #10 pan-head screws.

Note: If using a drain tray, the bottom of the side framing studs will be approximately 1" from the bottom of the firebox.

4. Locate the middle bracket. Loosen the screw in the middle top of the fireplace. Slide the bracket under the screw as shown in Figure 11. Tighten the hex-head screws on the fireplace secure a pan-head screw through the middle bracket and into the top stud.
5. Locate the two non-combustible boards and place them above the fireplace as shown in Figure 12. Attach the non-combustible board to the studs with six 10-16 flathead screws.
6. Secure the non-combustible board to the middle bracket using two 10-16 flathead screws as shown in Figure 12.
7. Move the fireplace into position. Connect the gas line to the unit and check for leaks with a soapy water solution.
Note: Ensure that the gas shut-off valve is accessible.
8. Secure fireplace to framing or floor.

GAS LINE CONNECTION

The fireplace is designed to accept a 3/8-inch gas line for an approved ventless gas logset. Have the line installed by a qualified service person in accordance with all building codes. Consult local building codes to properly size the gas supply line leading to the 3/8-inch hook-up at the unit. The state of Massachusetts requires that a flexible appliance connector cannot exceed three feet in length.

A flex-line and shut-off valve have been provided. **The gas shut-off valve must be located outside of the unit in an accessible area.**

Check gas type. Use only the gas type indicated on the gas log set rating plate. If the gas listed on the plate is not your type of gas supply, DO NOT INSTALL. Contact your dealer for proper model.

Always use an external regulator for all LP fireplaces to reduce the supply tank pressure to a maximum of 14" w.c. This is in addition to the regulator fitted to the log set.

WARNING: CONNECTION DIRECTLY TO AN UNREGULATED L.P. TANK CAN CAUSE EXPLOSION.

Install only a ANSI Z21.97.1/CSA 2.41 ventless log set into this fireplace.

OPERATION INSTRUCTIONS/FLAME APPEARANCE

Flames from the pilot (rear right back side of the pan burner) as well as the main flame should be visually checked as the burner cover is installed.

In normal operation at full rate after 10 to 15 minutes, the flame appearance should be sets of yellow flames.

NOTE: All flames will be random by design, flame height will go up and down.

During manufacturing, fabricating and shipping, various components of this appliance are treated with certain oils, films or bonding agents. These chemicals are not harmful, but may produce annoying smoke and smells as they are burned off during the initial operation of the appliance. This is a normal and temporary occurrence.

The initial break-in operation should last 2-3 hours with the burner at the highest setting. Any odors remaining after this initial break-in will be slight and will disappear with continued use.

PERIODIC CLEANING – Refer to parts diagram for location of items discussed below.

- Do not use cleaning fluid to clean any part of heater.
- Remove loose particles and dust from the burner areas, controls, piezo covers and grate.
- Inspect and clean burner air intake hole. Remove lint or particles with brush. Failure to keep air intake hole clean will result in sooting and poor combustion.

ANNUAL CLEANING/INSPECTION – Refer to parts diagram for location of items discussed below.

- Inspect and clean burner air intake hole. Remove lint or particles with vacuum or brush. Failure to keep air intake hole clean will result in sooting and poor combustion.
- Inspect and clean all burner ports.
- Inspect pilot for operation and accumulation of lint at air intake holes.
- Verify flame pattern for proper operation.
- Verify smooth and responsive ignition of main burner.



OLP(36,42)FP72 LIGHTING INSTRUCTIONS

FOR YOUR SAFETY READ BEFORE LIGHTING

WARNING: IF YOU DO NOT FOLLOW THESE INSTRUCTIONS EXACTLY, A FIRE OR EXPLOSION MAY RESULT CAUSING PROPERTY DAMAGE, PERSONAL INJURY, OR LOSS OF LIFE.

- A. **BEFORE LIGHTING**, smell around the appliance area for gas. Be sure to smell next to the floor because some gas is heavier than air and will settle on the floor.
- WHAT TO DO IF YOU SMELL GAS**
- Do not try to light any appliance.
 - Do not touch any electrical switch.
 - Do not use any phone in your building.
 - Immediately call your gas supplier from a neighbor's phone. Follow the gas supplier's instructions. If you can not reach your gas supplier, call the fire department.
- B. Use only your hand to push in or turn the gas control knob. Never use tools. If the knob will not push in or turn by hand, don't try to repair it, call a qualified service technician. Force or attempted repair may result in a fire or explosion.
- C. Do not use this appliance if any part has been under water. Immediately call a qualified service technician to inspect the appliance and to replace any part of the control system and any gas control which has been under water.

LIGHTING INSTRUCTIONS

1. **STOP!** Read the safety information above.
2. Turn gas cock counterclockwise  to "ON" position.
3. Wait ten (10) minutes to clear out any gas. Then smell for gas, including near the floor. If you smell gas, **STOP!** Follow "B" in the safety information above on this label. If you do not smell gas, go to the next step.
4. Turn ON electric power to the appliance.
5. Find spark and sensor probes.
6. Using the remote control, turn main flame to "ON." If the burner does not light within 60 seconds, stop and go to Step 5.
7. If the burner does not stay lit, stop and immediately call a qualified service technician or gas supplier.
8. If the burner does not operate properly after several tries, turn the gas control knob clockwise  to "OFF" and call your service technician or gas supplier.
9. Operation of the gas valve must be controlled by using the hand held remote control. Refer to remote instructions for detailed operation information.

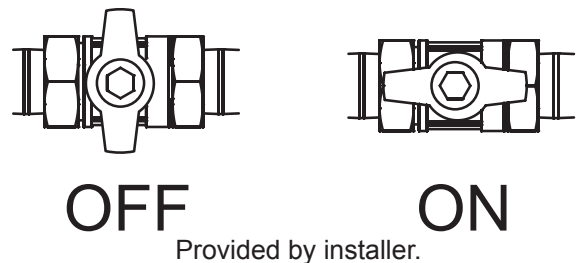
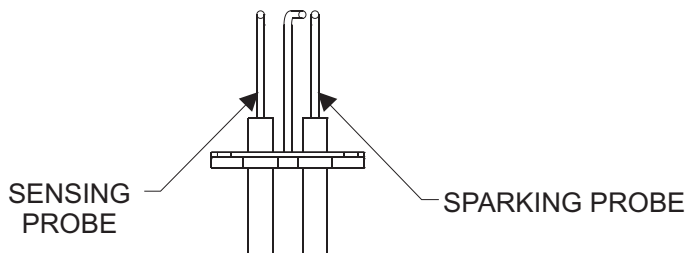

TO TURN OFF GAS TO APPLIANCE

1. Locate On/Off gas cock and turn clockwise to  "OFF." Do not force.

MAIN BURNER FLAME CHARACTERISTICS

If pilot flame pattern is incorrect
 • See Troubleshooting, page 16.

Main Burner Flame Pattern

The main burner flame will be completely yellow.

Main Burner Flame Ignition and Extinction

When the main burner is ignited it will take a few seconds for the full flame pattern to develop.

When the main burner is extinguished it will take a few seconds for the flames to disappear. It is normal to have the flames burn down near the burner, as the remaining gas is burned.

WIRING

Label all wires prior to disconnection when servicing controls. Wiring errors can cause improper and dangerous operation. Verify proper operation after servicing.

1. Remove batteries (4) and battery pack from instruction envelope package.
2. Slide battery cover plate off of battery pack, insert batteries (ensure correct polarity), and replace battery cover plate.
3. Connect red wire from battery pack to red wire from valve.

4. Connect black wire from battery pack to red wire from valve.
5. Attach wire harness from control module to battery pack.
6. Place battery pack on raised section of firebox bottom through hole in burner bottom.

Note: The fireplace may be operated without the remote by connecting the brown control module wires to a wall switch. The remote/off switch on the control module must be in the "OFF" position.

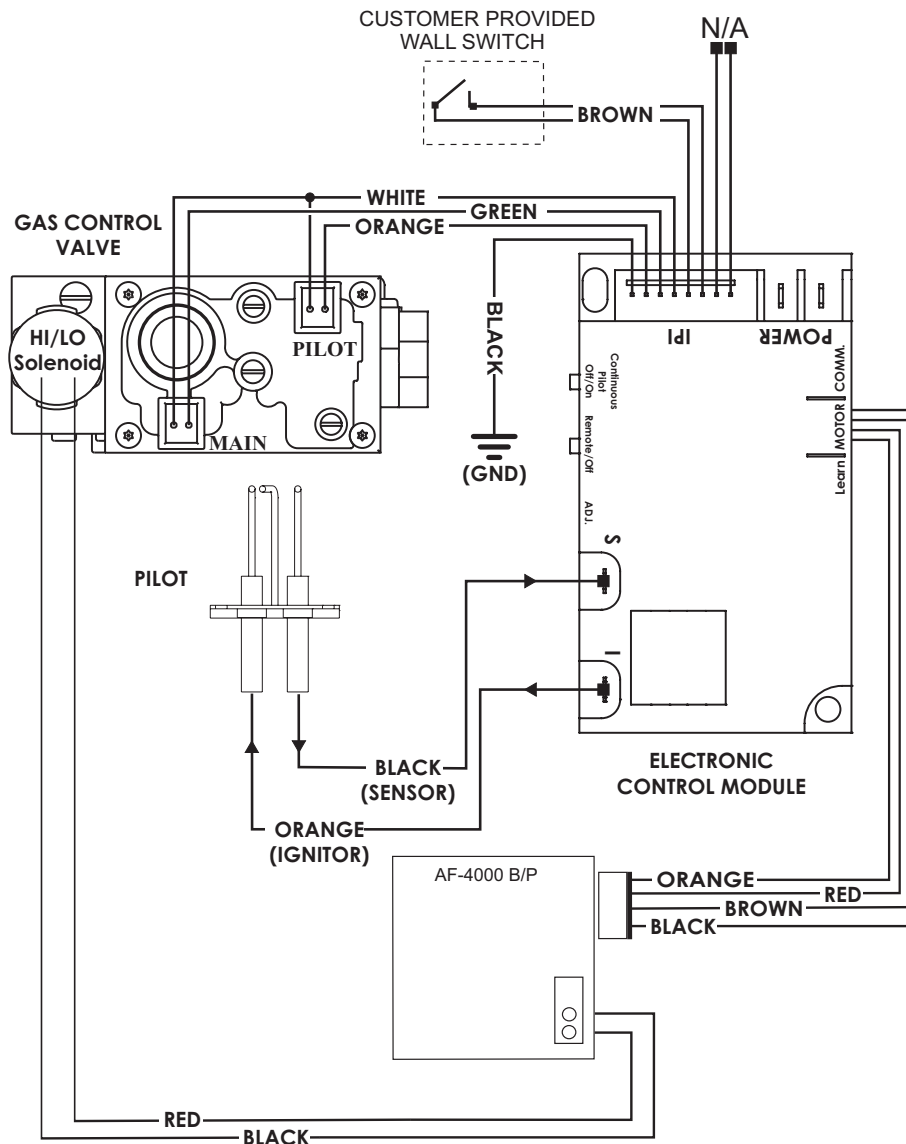

REMOTE CONTROL INSTALLATION & OPERATION

TWO-FUNCTION WIRELESS REMOTE CONTROL SYSTEM FOR ON/OFF-HI/LO OPERATION OF THE AF-4000 GAS CONTROL VALVE

**IF YOU CANNOT READ OR UNDERSTAND THESE INSTALLATION INSTRUCTIONS DO NOT
ATTEMPT TO OPERATE**

INTRODUCTION

This remote control system was developed to provide a safe, reliable, and user-friendly remote control system for use with the AF-4000 gas control valve used with some gas heating appliances. The system operates on radio frequencies (RF) within a 20' range using non-directional signals. The system operates on one of 255 security codes that are programmed into the transmitter at the factory; the remote receiver must learn the transmitter code prior to initial use.

TRANSMITTER

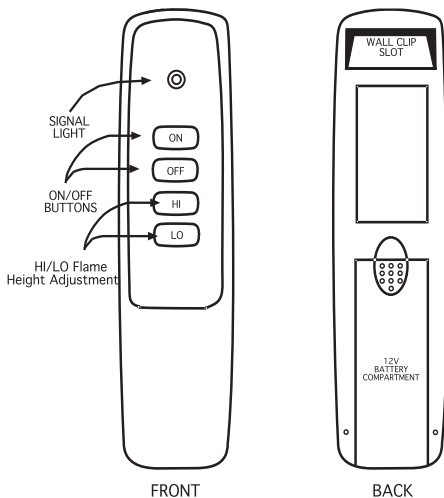

This remote control TRANSMITTER offers the user a battery-operated hand held control to operate the AF-4000 control module functions that are used with some decorative gas fireplaces and other gas heating appliances.

The transmitter operates with a 12V battery (Included) made specifically for remote controls and electronic lighters. Before using the transmitter, install the 12-volt (A-23) battery in the battery compartment.

It is recommended that ALKALINE batteries always be used for longer battery life and maximum operational performance.

The transmitter has ON/OFF and HI/LO functions that are activated by pressing the button on the face of the transmitter. When a button on the transmitter is pressed, a signal light on the transmitter illuminates to verify that a signal is being sent. Upon initial use, there may be a delay of three seconds before the remote receiver will respond to the transmitter. This is part of the system's design. If the signal light does not illuminate, check the position of the transmitter's battery.

MATCHING SECURITY CODES

Each transmitter can use one of 255 unique security codes. It may be necessary to program (LEARN FUNCTION) the module to accept the transmitter security code upon initial use, if batteries are replaced, or if a replacement transmitter is purchased from your dealer or the factory. In order for the module to accept the transmitter security code, be sure the slide button on the module is in the REMOTE position; the module will NOT "LEARN" if the slide switch is in the OFF position. Press and release the LEARN button on the module to accept the transmitter security code and then pressing any button on the transmitter. A change in the beeping pattern, at the module, indicates the transmitter's code has been accepted into the module. When an existing module has accepted the new transmitter code, the new security code will replace the old one.

The microprocessor that controls the security code matching procedure is controlled by a timing function. If you are unsuccessful in matching the security code on the first attempt, wait 1 - 2 minutes before trying again - this delay allows the microprocessor to reset its timer circuitry - and try up to two or three more times.

OPERATION

1. This remote control will operate the AF-4000 gas control valves ON/OFF and flame height HI/LO of the main burner.
2. When the ON button is depressed the transmitter sends a RF signal to the module. The module then sends 3 volts of power to the internal solenoid. The internal solenoid then opens the gas flow to the main burner ON/OFF. The system uses a pulse or continuous 3 volts DC power to operate the flame HI/LO solenoid or flame HI/LOW DC motor drive.

BATTERY LIFE

Life expectancy of the alkaline batteries in the RCAF-3 TX can be up to 12 months depending on use of the solenoid function. Check and replace all batteries annually. The transmitter should operate with as little as 9.0 volts battery power.

SPECIFICATIONS

BATTERIES: Transmitter 12V - (A23)
Operating Frequency: 303.8 MHZ

FCC ID No.'s: transmitter K9I1001
Canadian ISC ID No.'s: transmitter - 2439 102 728

FCC REQUIREMENTS

NOTE: THE MANUFACTURER IS NOT RESPONSIBLE FOR ANY RADIO OR TV INTERFERENCE CAUSED BY UNAUTHORIZED MODIFICATIONS TO THIS EQUIPMENT. SUCH MODIFICATIONS COULD VOID THE USER'S AUTHORITY TO OPERATE THE EQUIPMENT.

MAINTENANCE

Keep the control compartment and burner area surrounding the burner clean.

Always keep the appliance area clear and free from combustible materials, gasoline, and other flammable vapors and liquids.

Never obstruct the flow of combustion and ventilation air. Keep the front of the appliance clear of all obstacles and materials.

Cleaning Instructions

This appliance is built using mostly high-grade stainless steel to resist rust-through. In outdoor applications, all stainless steel will develop a dull patina and, depending on the local environment and on the materials used in the installation, may develop some surface oxidation (rust). This does not affect the performance of

the fireplace, and does not require any action to correct. If you prefer keeping your fireplace front looking factory-fresh, clean it as required with stainless steel cleaner.

When installation application includes highly acidic applications such as mortar or stone etching, do not remove the protective PVC film from the stainless steel until after this application is complete. Once the film has been removed we recommend that the appliance be cleaned with a stainless steel cleaner immediately.

Please note that areas where the film has been formed (corners, hems, etc.) may require extra cleaning due to the properties of the film. Ensure that all protective film has been removed from the fireplace prior to burning the appliance.

TROUBLESHOOTING

SYMPTOMS - POSSIBLE CAUSES AND CORRECTIONS

Turn appliance OFF and allow to cool before servicing. Only a qualified service person should service and repair the heater.

- 1. Appliance produces unwanted odors.**
 - a. Appliance burning vapors from paint, hair spray, glues, etc.
- Ventilate area. Stop using odor causing products while heater is running.
 - b. Gas leak - Locate and correct all leaks.
- 2. Appliance shuts off during use. (Pilot and main burner are off.)**
 - a. Low line pressure - Contact local gas company.
 - b. Pilot is partially clogged - Clean pilot.
 - c. Defective flame sensor - Replace spark probe.
 - d. Low batteries - Replace batteries in remote receiver.
- 3. Appliance shuts off during use.**
 - a. Low line pressure - Check line pressure to the valve.
 - b. Low batteries - Replace batteries in remote receiver.
- 4. Gas odor even when control knob is in OFF position.**
 - a. Gas leak - Locate and correct all leaks.
 - b. Control valve defective - Replace control valve.
- 5. Burner does not light.**
 - a. Burner orifice clogged - Clean burner or replace main burner orifice.
 - b. Burner orifice diameter is too small - Replace burner orifice.
 - c. Inlet gas pressure is too low - Contact qualified service person.
 - d. Low batteries - Replace batteries in remote receiver.
- 6. If burning at main burner orifice occurs (a loud, roaring blow torch noise).**
 - a. You must turn off burner assembly and contact a qualified service person.
 - b. Manifold pressure is too low - Contact local gas company.
 - c. Burner orifice clogged - Clean burner or replace burner orifice.
- 7. Appliance produces a whistling noise when main burner is lit.**
 - a. Turning control knob to HIGH position when main burner is cold - Turn control knob to LOW position and let warm up for a minute.
 - b. Air in gas line - Operate burner until air is removed from line. Have gas line checked by local gas company.
 - c. Dirty or partially clogged burner orifice - Clean burner or replace burner orifice.

If the gas quality is bad, your pilot may not stay lit, the burners may produce soot and the heater may backfire when lit. If the gas quality or pressure is low, contact your local gas supplier immediately.

MASTER PARTS DISTRIBUTOR LIST

To Order Parts Under Warranty, please contact your local Empire dealer. See the dealer locator at www.empirecomfort.com. To provide warranty service, your dealer will need your name and address, purchase date and serial number, and the nature of the problem with the unit.

To Order Parts After the Warranty Period, please contact your dealer or one of the Master Parts Distributors listed below. This list changes from time to time. For the current list, please click on the Master Parts button at www.empirecomfort.com. Please note: Master Parts Distributors are independent businesses that stock the most commonly ordered Original Equipment repair parts for Heaters, Grills, and Fireplaces manufactured by Empire Comfort Systems Inc.

Dey Distributing

1401 Willow Lake Boulevard
Vadnais Heights, MN 55101

Phone: 651-490-9191

Toll Free: 800-397-1339

Website: www.deydistributing.com

Parts: Heater, Hearth and Grills

Victor Division of F. W. Webb Company

200 Locust Street
Hartford, CT 06114

Phone: 860-722-2433

Toll Free: 800-243-9360

Fax: 860-293-0479

Toll Free Fax: 800-274-2004

Websites: www.fwwebb.com & www.victormfg.com

Parts: Heater, Hearth and Grills

East Coast Energy Products

10 East Route 36
West Long Branch, NJ 07764

Phone: 732-870-8809

Toll Free: 800-755-8809

Fax: 732-870-8811

Website: www.eastcoastenergy.com

Parts: Heater, Hearth and Grills

Able Distributors

2501 North Central Avenue
Chicago, IL 60639

Phone: 773-889-5555

Toll Free: 800-880-2253

Fax: 773-466-1118

Website: www.abledistributors.com

Parts: Heater

HOW TO ORDER REPAIR PARTS

Parts Not Under Warranty

Parts can be ordered through your Service Person, Dealer, or a Master Parts Distributor. See this page for the Master Parts Distributors list. For best results, the **service person or dealer** should order parts through the distributor. Parts can be shipped directly to the **service person/dealer**.

Warranty Parts

Warranty parts will need a proof of purchase and can be ordered by your Service Person or Dealer. Proof of purchase is **required** for warranty parts.

All parts listed in the Parts List have a Part Number. When ordering parts, first obtain the Model Number and Serial Number from the name plate on your equipment. Then determine the Part Number (**not** the Index Number) and the Description of each part from the following illustration and part list. Be sure to give all this information . . .

Appliance Model Number _____ Part Description _____

Appliance Serial Number _____ Part Number _____

Type of Gas (Propane or Natural) _____

Do not order bolts, screws, washers or nuts. They are standard hardware items and can be purchased at any local hardware store.

Shipments contingent upon strikes, fires and all causes beyond our control.

PARTS LIST

USE ONLY MANUFACTURER'S REPLACEMENT PARTS. USE OF ANY OTHER PARTS COULD CAUSE INJURY OR DEATH.

Index No.	Part No.		Description
	OLP36FP72	OLP42FP72	
1	23219	23219	Top Standoff
2	27781	27782	Firebox Front
3	32359	32359	Mount Bracket
4	34032	34032	Liner, Side - Left
5	34031	34031	Liner, Side - Right
6	34029	34030	Liner, Rear
7	10554	10554	Flange
12	21162	33609	Hood
13	R11036	R11037	Curtain, Rod
14	R10765	R10765	Curtain, Screen
15	R7572	R7572	Jamb Nut
16	R10808	R10808	Air Shutter
17	R2423	R2423	Connector, Male 5/16 X 3/8 NPT
18	28089	28089	Valve Shield
19	P212	P212	Orifice Fitting
20	P209	P209	Orifice - Nat
20	P245	P265	Orifice - LP
21	28111	28111	Module Shield
22	28739	28740	Burner Welded Assembly
24	R12005	R12005	Valve - Nat
24	R10810	R10810	Valve - LP
25	28084	28084	Inlet Tube Assembly
28	R10814	R10814	Spark Probe
29	R10813	R10813	Battery Pack
31	R10811	R10811	Control Module
33	28539	28539	Control Module Base
35	28106	28107	Bottom Base
36	28559	28560	Burner Cover Assembly
37	32231	32231	Metal Channel - Side
38	32233	32234	Metal Channel - Top
39	R11681	R11633	Non-Combustible Board
40	R11927	R11927	Shut-off Valve
Not Shown	R10812	R10812	Wire Harness, American Flame
Not Shown	R10815	R10815	Remote Control

PARTS VIEW

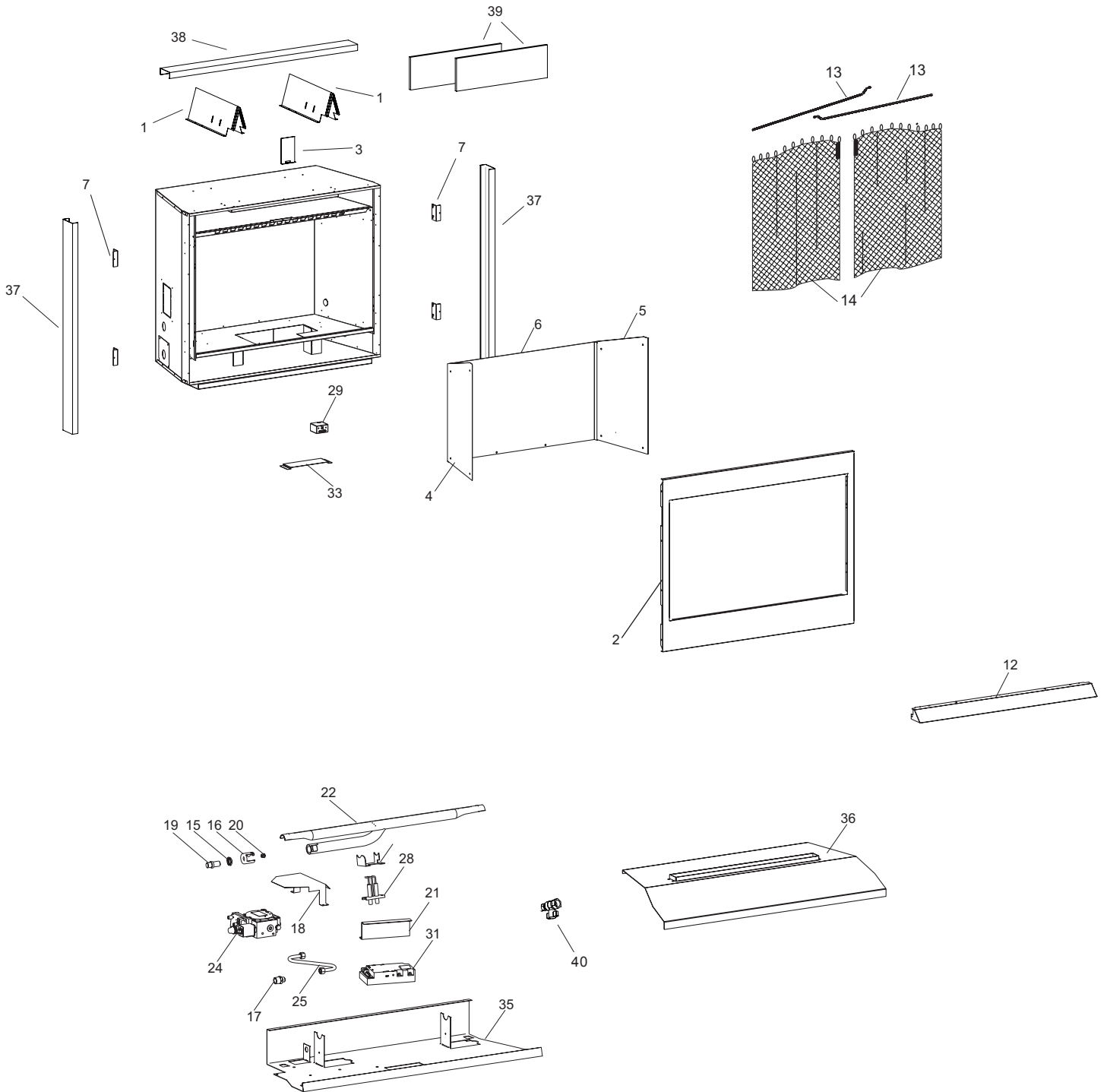

WARRANTY TERMS

Empire Comfort Systems Inc. warrants this hearth product to be free from defects at the time of purchase and for the periods specified below. Hearth products must be installed by a qualified technician and must be maintained and operated safely, in accordance with the instructions in the owner's manual. This warranty applies to the original purchaser only and is not transferable. All warranty repairs must be accomplished by a qualified gas appliance technician.

***Limited Five-Year Parts Warranty – All Components
(Except Remote Controls, Thermostats, Accessories and Replacement Parts)***

Should any part fail because of defective workmanship or material within five years from the date of purchase, Empire will repair or replace at Empire's option.

Limited One-Year Parts Warranty – Remote Controls, Thermostats, Accessories, and Parts

Should any remote control, thermostat, accessory, or other part fail because of defective workmanship within one year from the date of purchase, Empire will repair or replace at Empire's option.

Duties of the Owner

The appliance must be installed by a qualified installer and operated in accordance with the instructions furnished with the appliance.

A bill of sale, cancelled check, or payment record should be kept to verify purchase date and establish warranty period.

Ready access to the appliance for service.

What Is Not Covered

Damages that might result from the use, misuse, or improper installation of this appliance.

Travel, diagnostic costs and freight charges on warranted parts to and from the factory.

Claims that do not involve defective workmanship or materials.

Unauthorized service or parts replacements.

Removal and reinstallation cost.

Inoperable due to improper or lack of maintenance.

How To Get Service

To make a claim under this warranty, please have your receipt available and contact your installing dealer. Provide the dealer with the model number, serial number, type of gas, and purchase verification. The installing dealer is responsible for providing service and will contact the factory to initiate any warranted parts replacements. Empire will make replacement parts available at the factory. Shipping expenses are not covered.

If, after contacting your Empire dealer, service received has not been satisfactory, contact: Consumer Relations Department, Empire Comfort Systems Inc., PO Box 529, Belleville, Illinois 62222, or send an e-mail to info@empirecomfort.com with "Consumer Relations" in the subject line.

Your Rights Under State Law

This warranty gives you specific legal rights, and you may also have other rights, which vary from state to state.



Empire Comfort Systems Inc.
918 Freeburg Ave. Belleville, IL 62220

If you have a general question about our products, please e-mail us at
info@empirecomfort.com.

If you have a service or repair question, please contact your dealer.

www.empirecomfort.com