

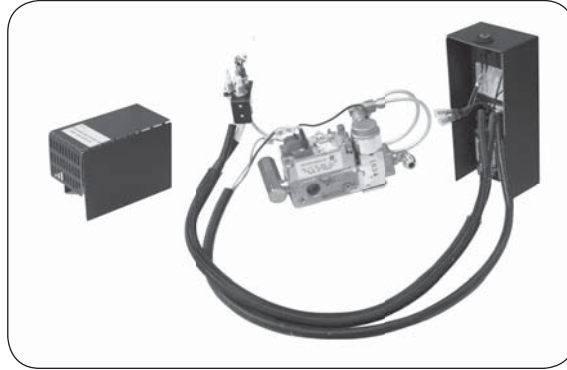

AUTOMATIC REMOTE LIGHTING SAFETY PILOT SYSTEM FOR NATURAL OR PROPANE GAS

Models:
EPK-1(M)(P)



FEATURES:

- INTERMITTENT PILOT IGNITION •
- NON-STANDING FLAME-SENSING PILOT •
- MANUAL SWITCH ON/OFF •
- OPTIONAL REMOTE CONTROL •

SUITABLE FOR THE FOLLOWING BURNERS:

- PAN BURNERS (P-SERIES) •
- G4 SERIES BURNERS •
- G45 SERIES BURNERS •

EPK-1 PILOT KITS

WARNING

If the information in this manual is not followed exactly, a fire or explosion may result, causing property damage, personal injury, or loss of life.

Do not store or use gasoline or other flammable vapors and liquids in the vicinity of this or any other appliance.

WHAT TO DO IF YOU SMELL GAS:

- Open a window.
- Do not try to light any appliance.
- Do not touch any electrical switch; do not use any phone in the building.
- Immediately call the gas supplier from a neighbor's phone and follow the gas supplier's instructions.
- If you cannot reach the gas supplier, call the fire department.

Installation and service must be performed by an NFI Certified or other qualified professional installer, service agency, or the gas supplier.

INSTALLER & CONSUMER

These instructions **MUST** be retained with this appliance

Important: Read these instructions carefully before starting installation of the burner control system.

The Peterson Real-Fyre® burner system is to be installed only in a solid-fuel-burning fireplace with a working flue constructed of noncombustible material. Solid fuels shall not be burned in a fireplace where the unit is installed. The installation, including provisions for combustion, ventilation air, and required minimum permanent vent opening, must conform with the *National Fuel Gas Code (ANSI Z223.1/NFPA 54)* and applicable local building codes. In Canada, the installation must conform with the *Natural Gas and Propane Storage and Handling Installation Code (CSA-B-149.1)*. A damper stop clamp is included to maintain the minimum permanent vent opening and to prevent full closure of the damper blade. **The chimney damper must be fixed fully opened when burning the unit. The burner system is designed to burn with yellow flames; thus, adequate ventilation is absolutely necessary.**



We recommend that our gas hearth products be installed and serviced by professionals who are certified in the U.S. by the National Fireplace Institute® (NFI) as NFI Gas Specialists.

TABLE OF CONTENTS

GETTING STARTED

IMPORTANT INFORMATION.....	3
SPECIFICATIONS.....	3
REPLACEMENT PARTS LIST.....	4

INSTALLATION

INSTALLATION.....	5
<i>PREPARATION</i>	5
<i>INSTALL VALVE</i>	5
<i>INSTALL FLAME DIVERTER BRACKET</i>	5
<i>INSTALL PILOT ASSEMBLY TO BURNER</i>	6
<i>CONNECT TO GAS SUPPLY</i>	7
<i>CHECKING THE IGNITION PACK</i>	8
<i>INSTALL/REPLACE BATTERIES FOR IGNITION MODULE PACK</i>	9
<i>CONNECT REMOTE RECEIVER (if equipped)</i>	9
<i>HEAT SHIELD PLACEMENT</i>	9
<i>SWITCH BOX PLACEMENT</i>	10
<i>DECORATIVE MEDIA REPLACEMENT</i>	10

USE, CARE, & SERVICE

LIGHTING INSTRUCTIONS.....	11
TROUBLESHOOTING.....	12
SYNCING THE REMOTE SYSTEM (IF APPLICABLE).....	12
<i>SYNCING THE REMOTE SYSTEM</i>	12
ELECTRONIC PILOT TROUBLESHOOTING.....	13
WARRANTY.....	14

IMPORTANT INFORMATION

CHECK TO BE SURE THAT THE PROPER FUEL GAS IS BEING USED WITH THIS PILOT KIT.

The installation, including provisions for combustion and ventilation air, must conform with local codes, or in the absence of local codes, with the National Fuel Gas Code (ANSI Z223.1/NFPA 54).

This component and its individual shutoff valve must be disconnected from the gas-supply piping system when testing at pressures that exceed 1/2 psig. This is accomplished by closing the gas-supply line valve.

This component must be isolated from the gas-supply piping system by closing its individual manual shutoff valve during any testing of the gas-supply system at test pressures up to and including 1/2 psig.

A fireplace screen must be in place when the gas burner system is in operation. Unless other provisions for combustion air are provided, the screen shall have an opening(s) for introduction of combustion air.

WHEN GLASS FIREPLACE ENCLOSURES (DOORS) ARE USED, OPERATE THE BURNER SYSTEM WITH THE GLASS DOORS FULLY OPEN; BOTH SIDES IF THE FIREPLACE IS A SEE-THROUGH TYPE.

This appliance may be installed in an aftermarket, permanently located, manufactured (mobile) home where not prohibited by local codes. Installation of appliances designed for manufactured homes or mobile homes must conform with *Manufactured Home Construction and Safety Standard, Title 24 CFR, Part 3280* in the U.S.; or with *CAN/CSA Z240 MH* in Canada; or with *ANSI/NCSCS A225.1/NFPA 501A, Manufactured Home Installations Standard* when such as standard is not applicable.

Do not use this appliance if any part has been underwater. Immediately call a qualified service technician to inspect the appliance and to replace any part of the control system and any gas control that has been underwater.

TO PREVENT VALVE DAMAGE AND FAILURE:

IT IS CRITICAL THAT THE HEAT SHIELD BE PLACED CORRECTLY OVER THE VALVE PRIOR TO OPERATION.

KEEP SAND, LAVA GRANULES, AND ALL FOREIGN OBJECTS AWAY FROM THE PILOT ASSEMBLY, VALVE ASSEMBLY, AND HEAT SHIELD DURING MEDIA PLACEMENT AND AT ALL TIMES.

SPECIFICATIONS

Minimum firebox dimensions required for burner system
(with EPK valve attached):

Burner size	Min. Firebox Dimensions		
	Center Width *	Depth	Height
16/19"	30"	11"	18"
18/20"	31"	14"	18"
24"	35"	14"	18"
30"	41"	15"	18"
36"	47"	16"	18"

* This required width allows for centering of the log set.

Table 1 - Minimum Firebox Dimensions

Model	BTUs	
	Nat.	L.P.
EPK-1	88 k	110 k

Table 2 - Maximum BTUs

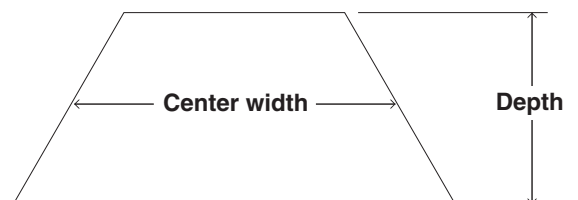

REPLACEMENT PARTS LIST

DO NOT REMOVE THE PILOT ASSEMBLY FROM THE VALVE OR SWITCH BOX.

Parts are shown below separated for identification purposes only.

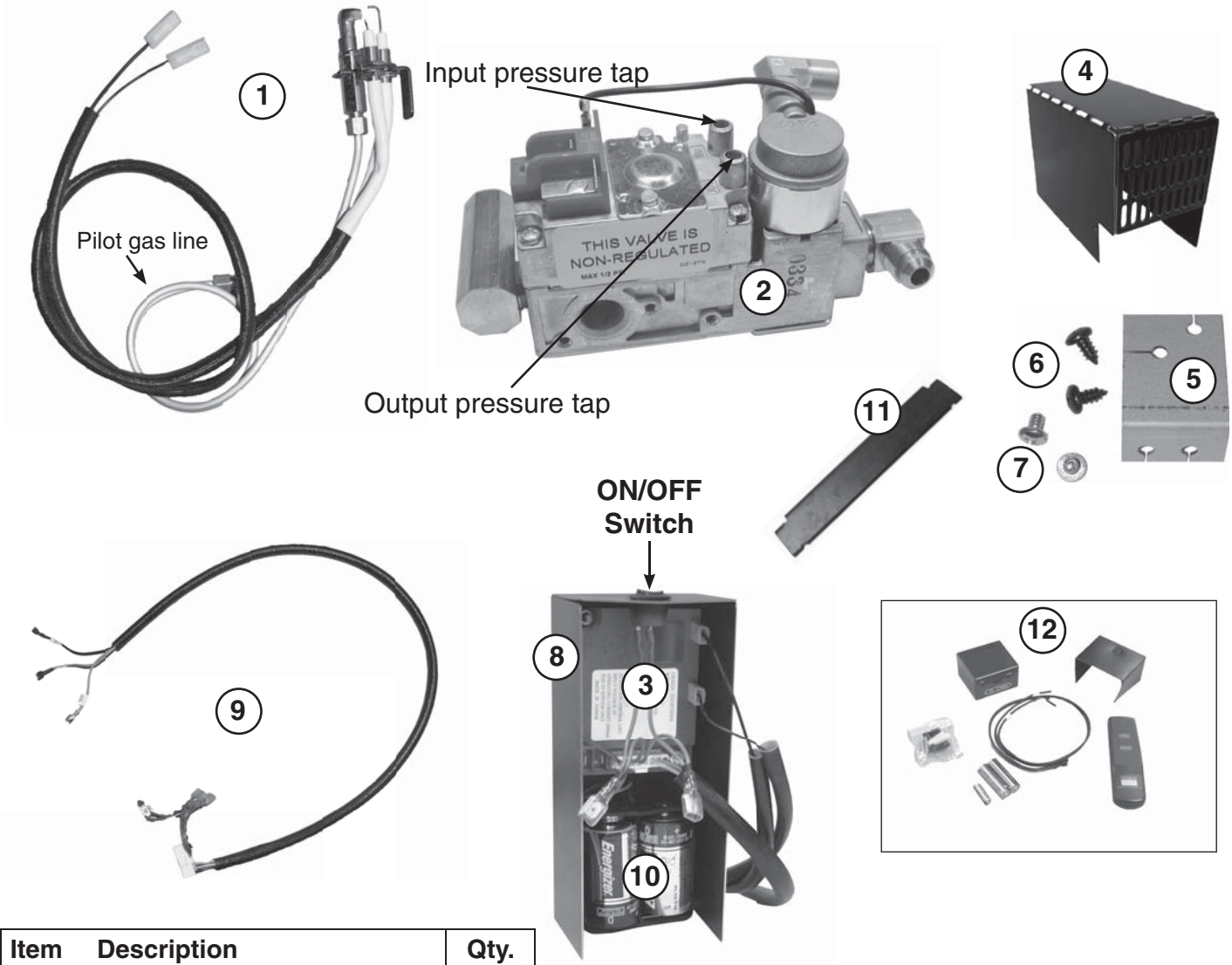

Photos not to scale

Item	Description	Qty.
1.	Pilot assembly, natural gas	1
or	Pilot assembly, propane gas	1
2.	Valve, natural or propane gas	1
3.	Ignition module pack	1
4.	Valve heat shield	1
5.	Pilot mounting bracket	1
6.	Screw #10 x 3/8" Phillips BLK	2
7.	Mounting screws 10-24 x 1/4"	2
8.	Switch box	1
9.	Wire harness, 24"	1
10.	Batteries (D-cells) (not installed)	2
11.	Flame diverter bracket	1
12.	Remote kit (if equipped)	1

INSTALLATION

This safety pilot system must be installed by a qualified professional service technician. Instructions must be followed carefully when installing to ensure proper performance and full benefit from the burner system and safety pilot system.

These instructions must be used as a supplement to the instructions supplied with the R.H. Peterson burner system. Follow the burner system instructions and make adjustments as appropriate for the addition of a safety pilot system. Use gas pipe sealing compound that is resistant to all gasses (or Teflon tape) and apply to all male pipe connections. **DO NOT** apply pipe sealing compound to any flare connections. Make sure that all connections are tight.

The valve system is shipped pre-assembled for easy installation onto the burner pan.

Note: Installation is easier when done outside of the fireplace.

PREPARATION

If the burner that the valve system is to be added to is already installed; remove all decorative media, set aside to be reinstalled later, and disconnect the flex connector and adapter from the burner pan (using the instructions that came with the original burner).

INSTALL VALVE

1. Apply gas pipe sealing compound (or Teflon tape) to the male end of the fuel injector or air mixer on the burner.
2. Install the valve to the fuel injector or air mixer by screwing the pan into the valve (Fig. 5-1). Take care not to damage the attached pilot assembly when rotating the burner pan. Be sure all connections are tight, however do not overtighten to prevent damage to the valve.

INSTALL FLAME DIVERTER BRACKET

For installation on G4/G45 burners only. When properly installed onto the burner pan, the flame diverter bracket will promote quicker ignition and protect the safety control system from overheating.

Note: You must first install the flame diverter bracket before installing the pilot/igniter assembly.

1. Place the flame diverter bracket over the side edge of the burner pan, near the location the safety control system pilot bracket will be attached. It should be placed **approximately 2-1/4"** from the rear wall of the burner pan (see Fig. 5-2).
2. Tap the bracket lightly with a rubber mallet to secure it in place.

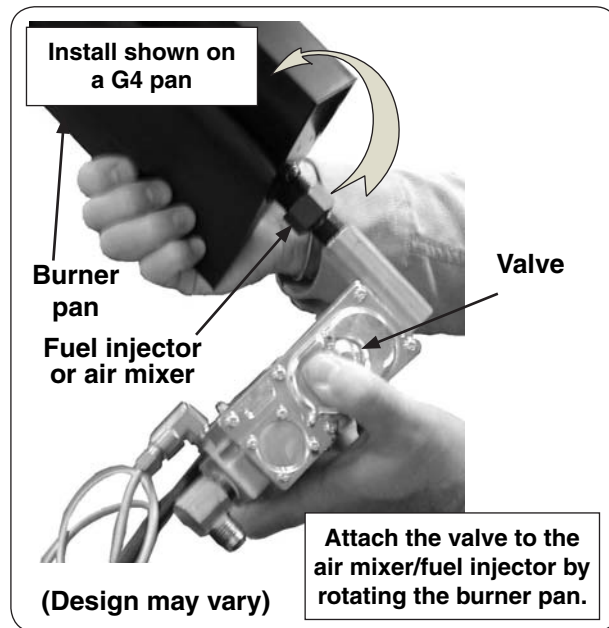

Fig. 5-1 Install valve

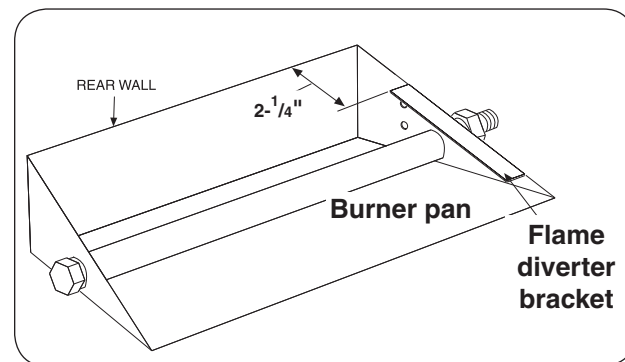

Fig. 5-2 Install diverter bracket (if applicable)

INSTALLATION (Cont.)

INSTALL PILOT ASSEMBLY TO BURNER

CAUTION: Use only the pilot assembly pre-assembled with this kit. Never substitute with an existing pilot.

CAUTION: Do not kink or damage the pilot supply tube, sparking, and sensor probes. Do not unscrew the gas line from the valve.

1. The pilot assembly comes with an L-shaped mounting bracket. Using the two black screws, fasten the bracket to burner pan (short side toward the back of the pan) using the pre-drilled holes in the pan (see Fig. 6-1).
2. Using the two (2) remaining screws, mount the pilot assembly onto the bracket (Fig. 6-2) and tighten until snug. **Check to be certain the pilot hood and probes are situated above the edge of the pan. Adjust if necessary.**

WARNING: Keep the pilot assembly clear at all times. Never cover any part of the pilot assembly.

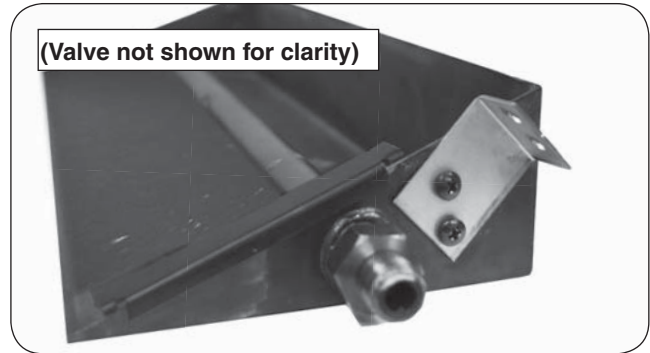

Fig. 6-1 Install pilot bracket

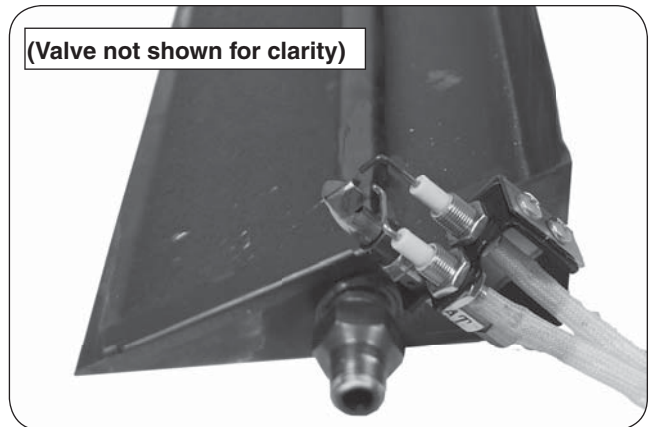

Fig. 6-2 Install pilot assembly

CONNECT TO GAS SUPPLY

To connect the valve to the gas supply, the flex connector kit and component parts will be needed, which are included with the burner system. Refer to the PARTS LIST in the instructions supplied with the burner to identify the key parts needed.

1. MAKE SURE THE FIREPLACE GAS SUPPLY IS TURNED OFF.
2. Locate the gas-supply stub inside the fireplace and remove the cap, if attached.

CAUTION: When removing the cap, make sure the stub does not turn, loosening the connection inside the wall.

3. Discard the small adapter included with burner flex connector kit. Attach one end of the flex connector (included with burner) to the elbow found on the control valve. Tighten securely. See Fig. 7-1.
4. Place the burner system in the fireplace. Center the burner in the fireplace.
5. **Be sure gas to the fireplace is off.** Attach the large adapter (included with burner flex connector kit) to the gas-supply stub using a pipe compound resistant to all gasses. Tighten securely. Then attach the open end of the flex connector to the large adapter. Tighten securely.
6. **LEAK TEST:** Turn on the fireplace gas supply, and test at all connections for leaks using the appropriate soapy water solution. If bubbles appear, a leak is present. Turn off the gas and tighten at all connections. Repeat until no leaks are present. If a leak persists, turn off the gas supply and contact the local gas company or dealer. **NEVER USE A FLAME TO CHECK FOR LEAKS.**
7. Follow the instructions supplied with the Peterson burner system for any additional requirements regarding specific burner setup and placement.

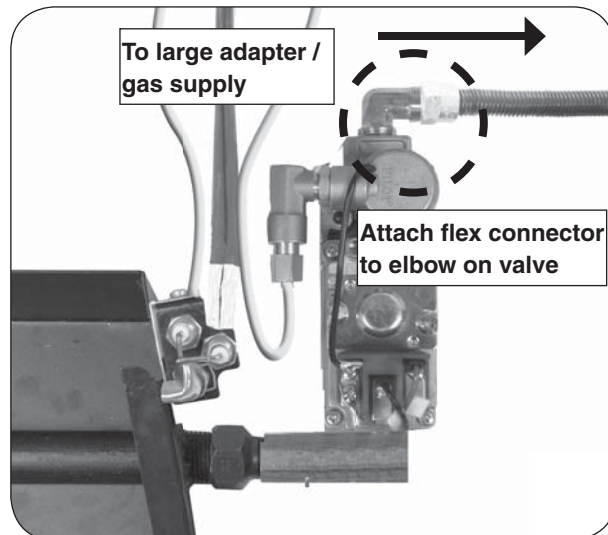

Fig. 7-1 Install flex connector to valve

INSTALLATION (Cont.)

CHECKING THE IGNITION PACK

The EPK-1(M)(P) valve comes completely assembled with the wiring harness already connected to the switch box assembly. However, we recommend that you follow the steps below to ensure it has not become detached during shipping **before** installing the batteries.

TO CHECK THE WIRING ASSEMBLY

1. Check that the wiring harness is fitted tightly into the connector on the green ignitor pack in the rear of the switch box (Fig. 8-1).
2. Check that the female connectors on the two black wires from the pilot assembly (wires marked "I" and "S") are inserted fully into the male connectors on the ignitor pack (Fig. 8-1).
3. Check the connection of the red and black wires of the wire harness to the respective counterpart wires from the battery holder (red-red and black-black). The two brown wires should be connected to the switch.

Note: The two (2) spare brown wires with coated male connectors are used to connect an optional remote system.

4. Check the connections of the wires to the EPK-1(M)(P) valve (see Fig. 8-2):

Orange wire marked **THTP** - to **THTP** connector on valve

Black wire marked **TP** - to **TP** connector on valve

Green wire marked **TH** - to **TH** connector on valve

The diagram below (Fig. 8-3) shows the wiring layout for the complete unit.

For installation of a remote system (if equipped), see instructions included in the remote kit figure on next page.

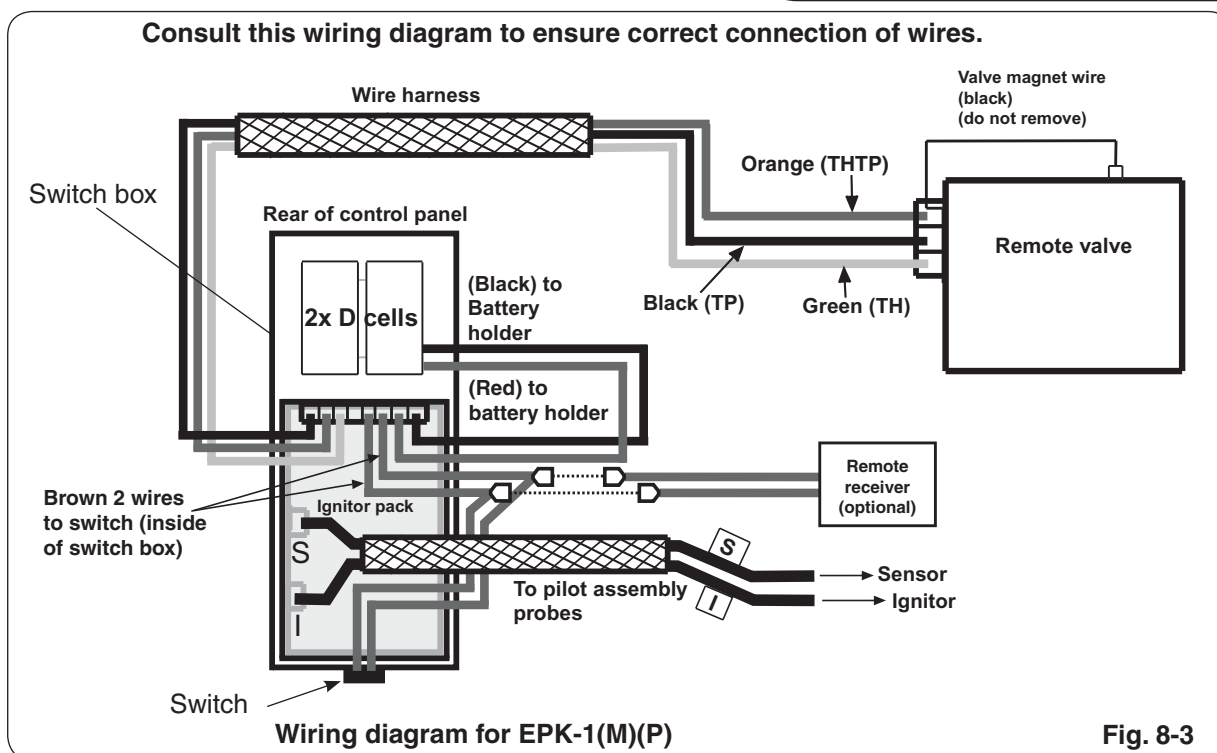
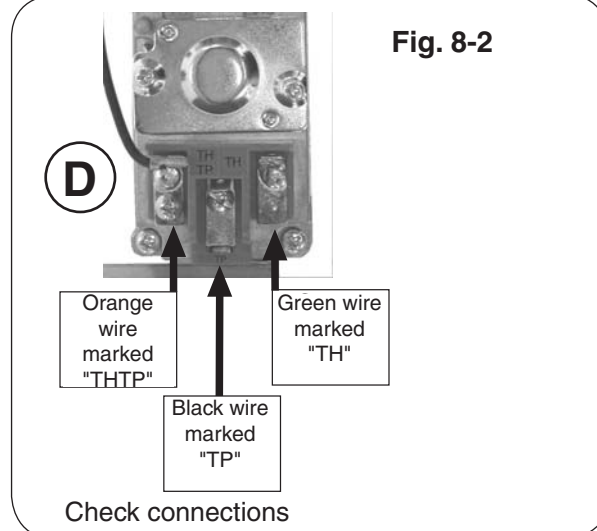
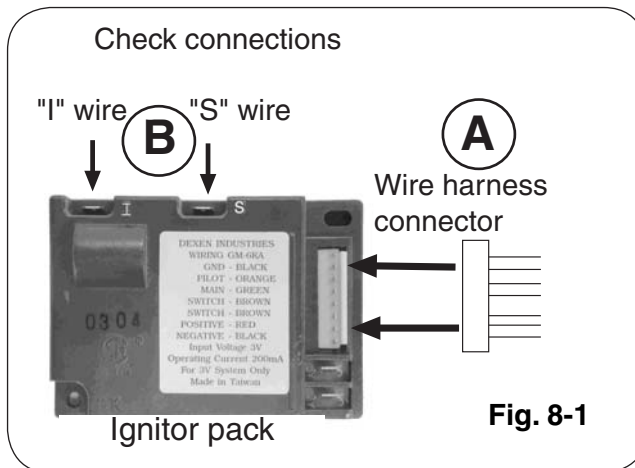

INSTALL/REPLACE BATTERIES FOR IGNITION MODULE PACK

Two 1.5-volt (D-cell) alkaline batteries are supplied with the burner system. To install or replace batteries, remove any old batteries (if applicable) and install new batteries according to the diagram illustrated on the battery holder mounted inside the switch box (Fig. 9-1).

Note: For the system to work properly, it is suggested that you replace the batteries annually with fresh batteries. Always replace both batteries at the same time.

CONNECT REMOTE RECEIVER (if equipped)

1. Install the provided batteries in the remote transmitter and receiver.
2. Connect the remote receiver wires to the switch box (see Fig 9-1).
3. Place the receiver as far from the burner system as possible (reference figure on next page).

Note: Place the receiver a minimum of 6" from the burner/flame.

4. Place the plastic cover over the remote receiver with the open side facing front to allow access to the receiver controls.

HEAT SHIELD PLACEMENT

TO PREVENT VALVE DAMAGE AND FAILURE:

IT IS CRITICAL THAT THE HEAT SHIELD BE PLACED CORRECTLY OVER THE VALVE PRIOR TO OPERATION.

TO PREVENT OVERHEATING THE VALVE:

Cover the valve with the heat shield as shown in Fig. 9-2. It should rest flat above the valve.

Keep the area above and below the heat shield clear of decorative media or any other objects at all times.

Important: Ensure the wire bundles do not interfere with heat shield placement. Reference figure on next page for example placement.

Important: Keep sand, lava granules, and all foreign objects away from the pilot assembly, valve assembly, and heat shield during media placement and at all times.

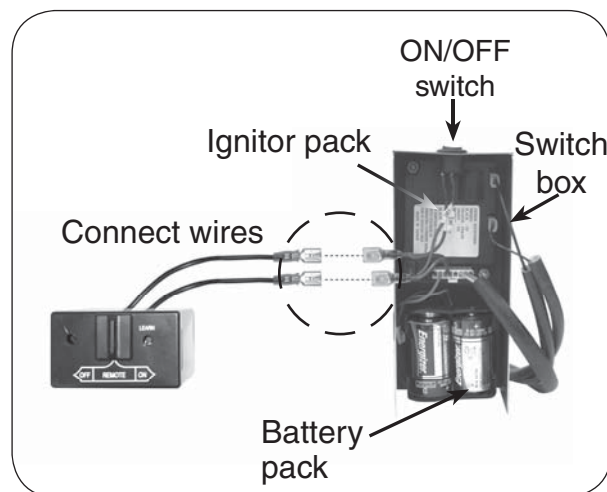

Fig. 9-1 Switch box detail

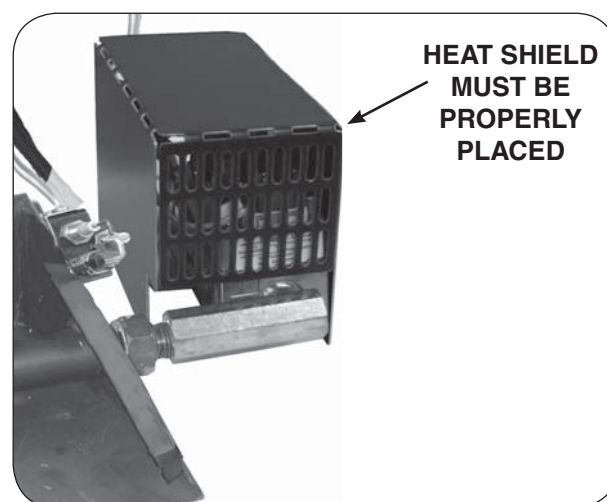

Fig. 9-2 Place heat shield

SWITCH BOX PLACEMENT

Place the switch box outside of the firebox and a minimum of 6" from the burner/flame. If the switch box is in the firebox, the switch box must only be oriented as shown in Fig. 10-1. The switch box must not be placed in the rear of the fireplace, or in any other manner than shown in Fig. 10-1. Set the box on its side and place the bottom of the box toward the right firebox wall (box must be a minimum of 6" from the burner/flame). Be sure that the pilot and valve wire bundles remain clear of the burner, valve, and heat shield at all times.

Note: Coil excess wire within the switch box.

CAUTION: THE SWITCH BOX MAY BE HOT DURING AND AFTER OPERATION.

EPK-1 installation is complete at this point. Ensure ALL information in this manual is followed to ensure proper operation.

DECORATIVE MEDIA REPLACEMENT

Refer to the burner instructions for proper placement of decorative media.

Important: Keep sand, lava granules, and all foreign objects away from the pilot assembly, valve assembly, and heat shield during media placement and at all times.

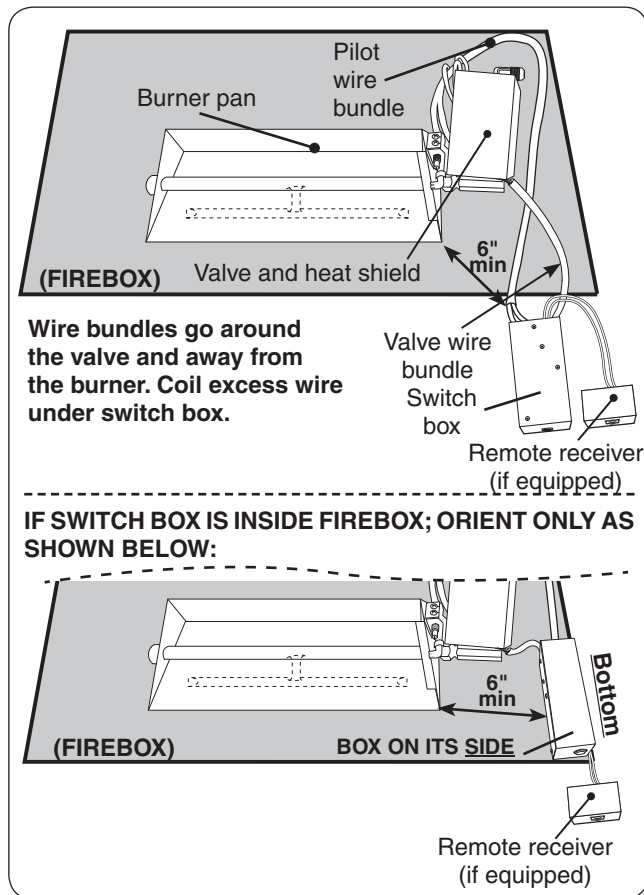

Fig. 10-1 Overall Orientation

LIGHTING INSTRUCTIONS

We recommend that before you install the burner system, you familiarize yourself with the control valve layout. This will help you to be confident operating the log set when fully installed.

FOR YOUR SAFETY, READ BEFORE LIGHTING

WARNING

If you do not follow these instructions exactly, a fire or explosion may result, causing property damage, personal injury, or loss of life.

The Real-Fyre® EPK-1(P) has a pilot that is lit using the ignitor switch. When lighting the pilot, follow these instructions exactly.

BEFORE LIGHTING, smell all around the gas log set area for gas. Be sure to smell next to the floor, as some gas is heavier than air and will settle on the floor. IF YOU SMELL GAS, FOLLOW THE INSTRUCTIONS ON THE FRONT COVER OF THESE INSTRUCTIONS.

TO LIGHT THE BURNER SYSTEM USING THE SWITCH BOX

Use the switch in front of the switch box (marked **I = IGNITE**; **O = OFF**, Fig. 11-1).

1. Press switch to **I (Ignite)**; see Fig. 11-2. This transmits a rapid series of sparks at the pilot head and will ignite the gas.
2. Sparks cease when the pilot flame is lit and stable. After a short time, the pilot will then light the main burner.

CAUTION: IF THE BURNER DOES NOT IGNITE WITHIN 20 SECONDS, STOP, WAIT 5 MINUTES, THEN REPEAT STEPS 1. AND 2. ABOVE.

If the pilot will not stay lit after several tries, turn the ignitor switch to **O (OFF)** and call the service technician or gas supplier.



Switch box

Fig. 11-1



Switch box
in ON position
Fig. 11-2



Switch box
in OFF position
Fig. 11-3

TO SHUT DOWN THE GAS LOG SET USING THE SWITCH BOX

Simply press the **O (OFF, Fig. 11-3)** switch in front of the switch box. The gas flow will cease, and all flames (main burner and pilot) will go out (see important note below).

OPERATING THE BURNER USING THE REMOTE CONTROL

If your EPK-1 came equipped with a remote, or if one was added later, follow the instructions included in the remote kit for lighting and shutting down the attached burner.

Important: Both the switch box switch and the remote control (if equipped) must be in the off state to shut the burner off. If one control is commanded off while the other is still on, the burner will remain on.

TROUBLESHOOTING

PROBLEM	CAUSE	SOLUTION
1. Pilot will not light	<ul style="list-style-type: none"> a. Obstruction in pilot gas supply or pilot gas-supply line is kinked b. Inadequate gas supply c. Air in line 	<ul style="list-style-type: none"> a. Clear out obstruction. Replace pilot gas-supply line if kinked b. Have gas pressure checked by installer or gas supplier c. Air should clear; attempt to relight
2. No spark at pilot	<ul style="list-style-type: none"> a. Loose wires b. Dead batteries c. Faulty switch or remote (if equipped) 	<ul style="list-style-type: none"> a. Check all wires are securely in place b. Replace batteries c. Replace the switch box unit or remote system as appropriate
3. Pilot lights, but main burner will not	<ul style="list-style-type: none"> a. Wire leads are not connected to proper valve terminals or toggle switch terminals not tight b. Batteries too low for voltage output c. Defective valve 	<ul style="list-style-type: none"> a. Make sure all wire leads are tight and attached to proper terminals (see wiring diagram section) b. Replace with new ones c. Replace valve
4. Log set not burning properly	<ul style="list-style-type: none"> a. Low flame/uneven flame 	<ul style="list-style-type: none"> a. Check for low gas pressure; should have operating pressures of 7" w.c. for natural gas, 11" w.c. for propane at manifold b. Burner should be filled completely with sand or vermiculite
5. Log set shuts down during operation	<ul style="list-style-type: none"> a. Glass doors closed, causing excessive heat buildup b. Pilot electrode not properly set to pilot location c. Heat shield not in place 	<ul style="list-style-type: none"> a. Open glass doors b. See INSTALL PILOT ASSEMBLY TO BURNER section c. Place heat shield over valve. Be sure the solid black face of the shield is between the valve and the burner
6. Intermittent ignitor spark during use (main burner has been burning for well over a minute).	<ul style="list-style-type: none"> a. Embers or sand covering pilot assembly 	<ul style="list-style-type: none"> a. Clear all foreign material from around the pilot assembly

Periodically inspect the pilot assembly and valve controls and maintain them free of obstruction or debris. If the pilot flame is not blue with possibly yellow tips and does not impinge on the electrodes or if the pilot does not stay lit, contact a qualified professional service technician to service the pilot system.

SYNCING THE REMOTE SYSTEM (IF APPLICABLE)

SYNCING THE REMOTE SYSTEM

Ensure the burner system is off and completely cool.

Locate the 3-position switch on the remote receiver and slide it to the **REMOTE** position. Next press the **LEARN** button and release. See Fig. 12-1. A beep will be heard. Then press and hold the **ON** button on the remote transmitter; a series of beeps should be heard. The remote system is now synced. Refer to the LIGHTING INSTRUCTIONS to test.

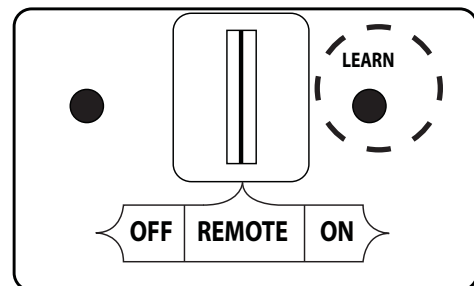

Fig. 12-1 Remote receiver sync detail

Detail A

Electrode (A)

When adjusting the spark electrode (if necessary); NEVER adjust the electrode by bending the wire. ALWAYS adjust the electrode by loosening the retainer nut(s), then adjust accordingly.

The minimum gap between the spark electrode/sensor electrode and the pilot flame hood is 1/8". The maximum is 5/32".

If the electrode ceramic is loose in the threaded barrel; the pilot assembly must be replaced.

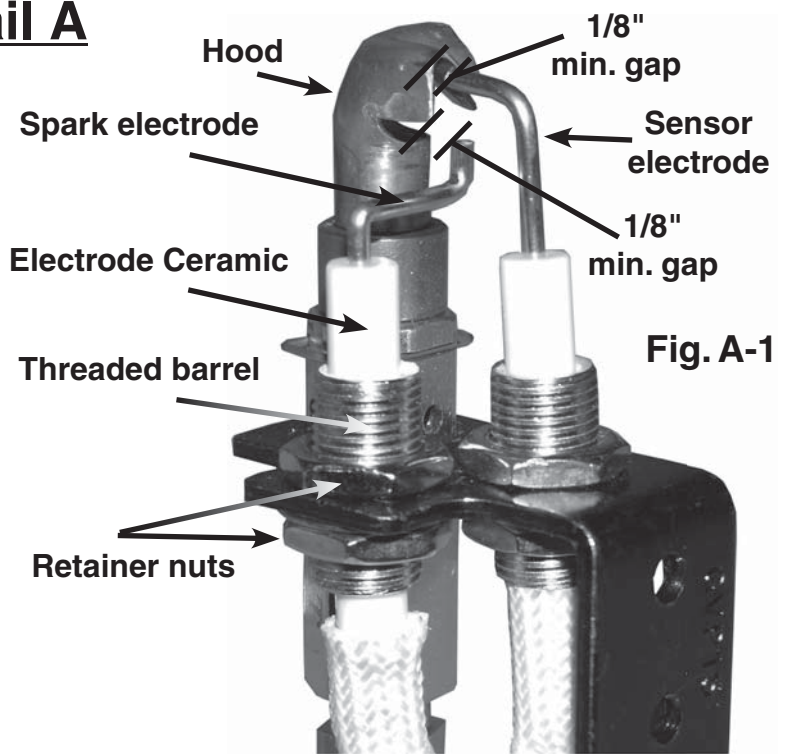

Fig. A-1

Detail B

Terminal Connections (B)

All of the connections on the control module must be properly attached. If the spade terminals are loose; inspect to ensure they correctly appear as detailed below. Use needle nose pliers to clamp down on the center/sides of the terminals if needed (to provide a tight fit.)

Spade Terminal Detail



Ensure that spade terminals (S and I) are attached securely

Ensure that multi-wire connector is properly locked in place

Control Module (DESIGN MAY VARY) (Fig. B-2)

Tighten terminals if needed

(Fig. B-3)

Detail C

(Fig. C-1)

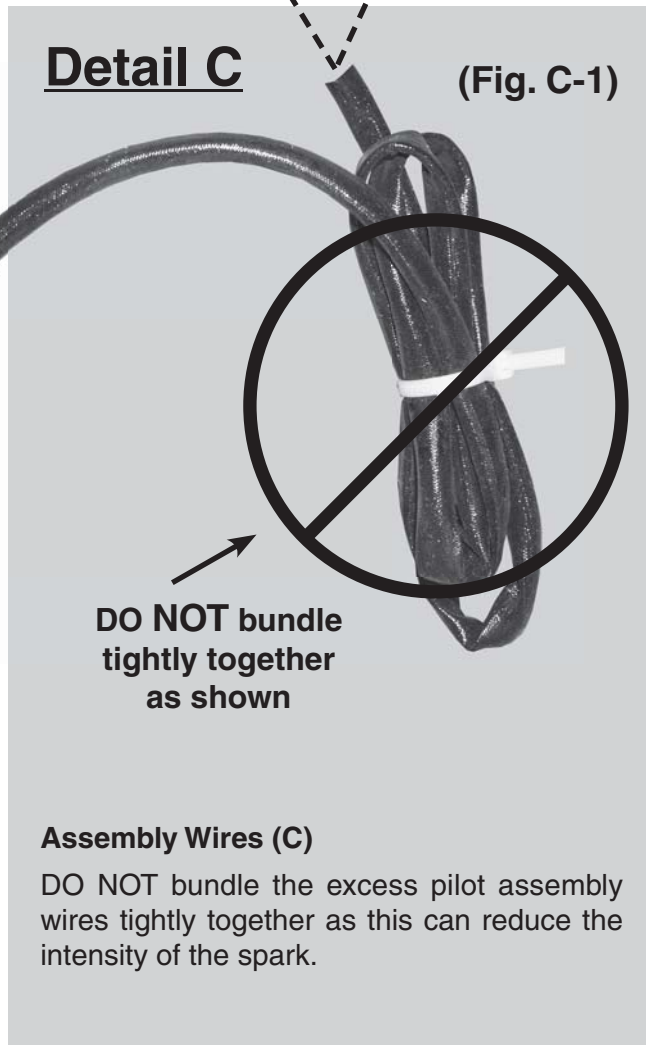

DO NOT bundle tightly together as shown

Assembly Wires (C)

DO NOT bundle the excess pilot assembly wires tightly together as this can reduce the intensity of the spark.

WARRANTY

PETERSON VENTED DECORATIVE GAS APPLIANCE LIMITED WARRANTY

Robert H. Peterson Co. ("RHP") warrants your Real Fyre® vented decorative gas appliance to be free from defects in material and workmanship.

Peterson vented ceramic refractory gas logs are warranted for **as long as you own them (lifetime)**.

Peterson vented burner assemblies are **WARRANTED for TEN (10) YEARS**. Peterson vented outdoor stainless-steel burner assemblies are warranted for **FIVE (5) YEARS**.

Peterson glass, gems, nuggets, and fiber-ceramic blend gas logs are warranted for **FIVE (5) YEARS**.

SPK-26 controls are warranted for **THREE (3) YEARS**.

APK-17 controls (including -17 valve) are warranted for **TWO (2) YEARS**.

All other Peterson valves, pilots, and controls are warranted for **ONE (1) YEAR (excluding batteries)**.

A COPY OF YOUR SALES SLIP FOR PROOF OF PURCHASE IS REQUIRED

This warranty applies to the original purchaser for products which are installed in the United States or Canada and which are operated and maintained as intended for single family residential usage. This warranty is valid only with proof of purchase, shall commence on the date of purchase, and shall terminate (both as to original and any replacement products) on the anniversary date of the original purchase of the product stated on the above schedules.

This warranty covers defects in material and workmanship. This warranty **does not** cover parts which become defective as a result of negligence, misuse, use not in compliance with the Owner's Manual/Installation Instructions, accidental damage, improper handling, improper storage, improper installation, lack of required routine maintenance (as specified in the Owner's Manual/Installation Instructions), electrical damage, local gas impurities or failure to protect against combustibles. Product must be installed (and gas must be connected) as specified in the Owner's Manual/Installation Instructions by a **qualified professional installer**. Modifications to products which are not specifically authorized will void this warranty. Accessories, parts, valves, remotes, etc. when used must be Peterson products or this warranty is void. Warrantied items will be repaired or replaced at Peterson's sole discretion. This warranty **does not** apply to rust, corrosion, oxidation, or discoloration unless the affected part becomes inoperable.

This warranty **does not** cover labor or labor related charges, except as provided by separate specific written programs from the Peterson Co. All repair work must be performed by a qualified professional service person and requires prior approval of Peterson.

Peterson may require the defective product or part to be returned to the factory to determine the cause of failure. Peterson will pay freight charges if the product or part is determined to be defective. This warranty does not cover breakage in shipment from our (Independent) distributor to its customer if the damage is determined to have occurred during that shipment.

This warranty specifically excludes liability for **indirect, incidental, or consequential damages**. Some states and provinces do not allow the exclusion or limitation of incidental or consequential damages, so the above exclusion may not apply to you. This warranty gives you specified legal rights, and you may have other rights that vary from state to state or province.

For additional information regarding this warranty, or to place a warranty claim, contact the R. H. Peterson dealer where the product was purchased.

**TO REGISTER YOUR PRODUCT ONLINE GO TO: WWW.RHPETERSON.COM,
AND CLICK ON PRODUCT REGISTRATION. THANK YOU FOR YOUR PURCHASE.**

Quality Check		Date: _____	
Leak Test: _____	Burn Test: _____	Gas Type:	Nat. / L.P.
Inspector: _____			