



Unvented Gas Log Heater or Vented Decorative Appliance

Models:

DEB20, DEB24, DEB30

Installation and
Operating Instructions

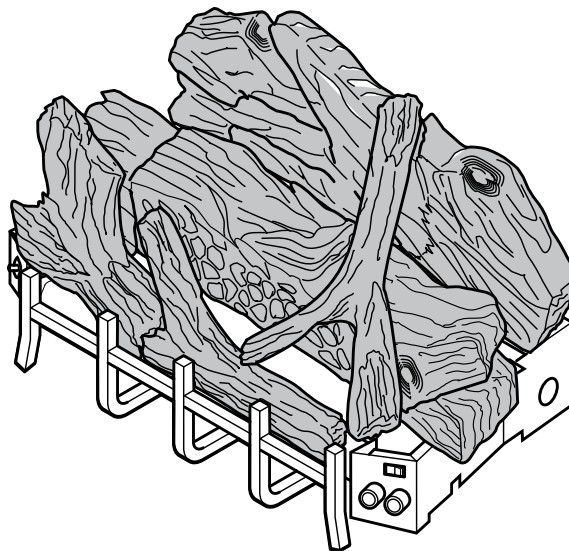

WARNINGS

If the information in this manual is not followed exactly, a fire or explosion may result causing property damage, personal injury or loss of life.

- Do not store or use gasoline or other flammable vapors and liquids in the vicinity of this or any other appliance.
- **WHAT TO DO IF YOU SMELL GAS**
 - Do not try to light any appliance.
 - Do not touch any electrical switch; do not use any phone in your building.
 - Immediately call your gas supplier from a neighbor's phone. Follow the gas supplier's instructions.
 - If you cannot reach your gas supplier, call the fire department.
- Installation and service must be performed by a qualified installer, service agency or the gas supplier.



This appliance may be installed in an aftermarket, permanently located, manufactured (mobile) home, where not prohibited by local codes.

This appliance is only for use with the type of gas indicated on the rating plate. This appliance is not convertible for use with other gases.

This is an unvented gas-fired heater. It uses air (oxygen) from the room in which it is installed. Provisions for adequate combustion and ventilation air must be provided. Refer to Page 6.

INSTALLER: Leave this manual with the appliance.
CONSUMER: Retain this manual for future reference.

Thank you and congratulations on your purchase of an Monessen Log Set.

PLEASE READ THE INSTALLATION AND OPERATION INSTRUCTIONS BEFORE USING THE APPLIANCE!

IMPORTANT: Read all instructions and warnings carefully before starting installation.

Failure to follow these instructions may result in a possible fire hazard and will void the warranty.

Important Safety Information	3	Electrical Wiring - Millivolt.....	14
Codes.....	4	Connect Wall Switch or Thermostat.....	14
Product Features	5	Connect Remote Receiver.....	15
Gas Specifications	5	Install Thermostat Sensor	15
Gas Pressures	5	Operation of Thermostat Sensor.....	17
Ignition Controls	5	Check System Operation	17
Pilot.....	5	Log Placement	18
Thermal Generator.....	5	Flame Appearance.....	20
Getting Started.....	6	Millivolt/Thermostat Control	20
Fireplace and Hearth Dimensions	7	Manual Control.....	20
Placement in a Fireplace with Restrictive Barrier	7	Burner Flame Appearance	21
Clearances and Height Requirements	8	Operating Instructions	22
Installation Requirements.....	9	For Your Safety Read Before Lighting	23
Installation.....	11	Manual Control	24
Installing Vented Applications	11	Millivolt/Thermostat Control	25
Damper Stop Installation.....	11	To Turn Off Gas to Heater	25
Place and Secure Appliance	11	Match Lighting Instructions	26
Assembly Procedure.....	12	Cleaning and Servicing.....	26
Gas Line Connection	12	Troubleshooting	27
Check Gas Pressure	13	Replacement Parts	29
Manual Control.....	13	Burner Assembly.....	29
Millivolt/Thermostat Control	13	Accessories.....	30
		Logs	31
		Massachusetts Residents Only.....	34
		Warranty	35

INSTALLER

Please leave these instructions with the appliance.

OWNER

Please retain these instructions for future reference.

WARNING	<ul style="list-style-type: none"> • Any change to this heater or its controls can be dangerous. • Improper installation or use of the heater can cause serious injury or death from fire, burns, explosion or carbon monoxide poisoning. • Do not allow fans to blow directly into the fireplace. Avoid any drafts that alter burner flame patterns. • Do not use a blower insert, heat exchanger insert or other accessory, not approved for use with this heater where applicable.
---------	---

1. Due to high temperatures, the appliance should be located out of traffic and away from furniture and draperies.
2. Children and adults should be alerted to the hazard of high surface temperature and should stay away to avoid burns or clothing ignition.
3. Young children should be carefully supervised when they are in the same room with the appliance.
4. Do not place clothing or other flammable material on or near the appliance.
5. Any safety screen or guard removed for servicing an appliance, must be replaced prior to operating the heater.
6. Installation and repair should be done by a qualified service person.
7. To prevent malfunction and/or sooting, an unvented gas heater should be cleaned before use and at least annually by a professional service person. More frequent cleaning may be required due to excessive lint from carpeting, bedding material, etc. It is imperative that control compartments, burners and circulating air passageways be kept clean.

8. **CARBON MONOXIDE POISONING:** Early signs of carbon monoxide poisoning are similar to the flu with headaches, dizziness and/or nausea. If you have these signs, obtain fresh air immediately. Have the heater serviced as it may not be operating properly.
9. The installation must conform with local codes or, in the absence of local codes, with the National Fuel Gas Code, ANSI Z223.1/NFPA54.
10. This unit complies with the latest edition of ANSI Z21.11.2 Unvented Heaters and also complies with ANSI Z21.60 / CSA 2.26 Decorative Vented Appliances for Solid Fuel Burning Fireplaces. State and local codes may only allow operation of this appliance in a vented configuration. Check your state or local codes. For vented operation, see "Vented Instructions" in this manual.
11. Do not install the heaters in a bathroom or bedroom.

12. Correct installation of the ceramic fiber logs, proper location of the heater, and annual cleaning are necessary to avoid potential problems with sooting. Sooting, resulting from improper installation or operation, can settle on surfaces outside the fireplace. See log placement instructions for proper installation.
13. Avoid any drafts that alter burner flame patterns. Do not allow fans to blow directly into fireplace. Do not place a blower inside burn area of firebox. Ceiling fans may create drafts that alter burner flame patterns. Sooting and improper burning will occur.
14. **CAUTION:** Candles, incense, oil lamps, etc. produce combustion byproducts including soot. Vent-free appliances will not filter or clean soot produced by these types of products. In addition, the smoke and/or aromatics (scents) may be reburnt in the vent-free appliance which can produce odors. It is recommended to minimize the use of candles, incense, etc. while the vent-free appliance is in operation.
15. This is an unvented gas-fired heater. It uses air (oxygen) from the room in which it is installed. Provisions for adequate combustion and ventilation air must be provided. *Refer to Page 6.*
16. This heater shall not be installed in a room or space unless the required volume of indoor combustion air is provided by the method described in the *National Fuel Gas Code, ANSI Z223.1/NFPA 54, the International Fuel Gas Code* or applicable local codes.
17. Keep room area clear and free from combustible materials, gasoline and other flammable vapors and liquids.
18. Unvented gas heaters are a supplemental zone heater. They are not intended to be the primary heating appliance.
19. Unvented gas heaters emit moisture into the living area. In most homes of average construction, this does not pose a problem. In houses of extremely tight construction, additional mechanical ventilation is recommended.
20. During manufacturing, fabricating and shipping, various components of this appliance are treated with certain oils, films or bonding agents. These chemicals are not

harmful but may produce annoying smoke and smells as they are burned off during the initial operation of the appliance; possibly causing headaches or eye or lung irritation. This is a normal and temporary occurrence.

The initial break-in operation should last two to three hours with the burner at the highest setting. Provide maximum ventilation by opening windows or doors to allow odors to dissipate. Any odors remaining after this initial break-in period will be slight and will disappear with continued use.

21. Input ratings are shown in BTU per hour and are for elevations up to 2,000 feet. For elevations above 2,000 feet, input ratings should be reduced 4 percent for each 1,000 feet above sea level. Refer to the National Fuel Gas Code.
22. The appliance and its appliance main gas valve must be disconnected from the gas supply piping system during any pressure testing of that system at test pressures in excess of 1/2 psig (3.5 kPa).
23. The appliance must be isolated from the gas supply piping system by closing its equipment shutoff valve during any pressure testing of the gas supply piping system at test pressures equal to or less than 1/2 psig (3.5 kPa).
24. Do not use this room heater if any part has been under water. Immediately call a qualified service technician to inspect the room heater and to replace any part of the control system and any gas control which has been under water.
25. This appliance must not be used with glass doors in the closed position. This can lead to pilot outages and severe sooting outside the fireplace.
26. Never burn solid fuels in a fireplace where a unvented room heater is installed.
27. Always have a fireplace screen in place when the appliance is in operation and, unless other provisions for combustion air are provided, the screen must have an opening(s) for induction of combustion air.

WARNING

Never connect unit to private (non-utility) gas wells. This gas is commonly known as wellhead gas.



CODES

Adhere to all local codes or, in their absence, the latest edition of THE NATIONAL FUEL GAS CODE ANSI Z223.1 or NFPA54 which can be obtained from...

American National Standards Institute, Inc.
1430 Broadway
New York, NY 10018

or

National Fire Protection Association, Inc.
Batterymarch Park
Quincy, MA 02269

GAS SPECIFICATIONS

Model	Fuel	Control	Min. Input BTU/h	Max. Input BTU/h
DEB20NM	Nat.	Manual	18,000	28,000
DEB20PM	LP	Manual	18,000	28,000
DEB24NM	Nat.	Manual	20,000	38,000
DEB24PM	LP	Manual	20,000	38,000
DEB30NM	Nat.	Manual	20,000	38,000
DEB30PM	LP	Manual	20,000	38,000
DEB20NV	Nat.	Millivolt	18,000	28,000
DEB20PV	LP	Millivolt	20,000	28,000
DEB24NV	Nat.	Millivolt	25,000	38,000
DEB24PV	LP	Millivolt	30,000	38,000
DEB30NV	Nat.	Millivolt	25,000	38,000
DEB30PV	LP	Millivolt	30,000	38,000

GAS PRESSURES

	Natural	Propane (LP)
Manual Regulator Pressure	3.0" w.c.	10.0" w.c.
Millivolt Regulator Pressure	3.5" w.c.	10.0" w.c.
Millivolt Pilot Regulator	3.5" w.c.	n/a
Max. Gas Inlet Pressure	10.5" w.c.	13.0" w.c.
Min. Gas Inlet Pressure	5.0" w.c.	11.0" w.c.

NOTE: An external regulator is required to reduce supply pressure to a maximum of 10.5" w.c. on Natural Gas systems operating at higher pressure.

NOTE: An external regulator is required to reduce supply pressure to a maximum of 13.0" w.c. for LP systems.

IGNITION CONTROLS

Piezo ignitor allows ignition of the pilot without the use of matches or batteries.

Manual control has three (3) positions:

- OFF** - All gas to the gas logs is shut off at the valve.
- IGN** - Valve position to light/maintain a standing pilot.
- HI/LOW** - Variable position corresponding to desired flame height.

Millivolt control has four (4) positions:

- OFF** - All gas to the gas logs is shut off at the valve.
- IGN** - Valve position to light/maintain a standing pilot.
- ON** - Valve position to turn ON/OFF log set with remote switch/thermostat.
- LOW/HI** - Variable position to control flame height (heat output).

PILOT/ODS

The gas log heater is fitted with a specially designed safety pilot (ODS assembly) which senses the amount of oxygen available in the room and shuts the gas log heater off if the oxygen level begins to drop below a satisfactory level. The pilot can only be relit when adequate fresh air is available.

THERMAL GENERATOR

The millivolt gas log pilot is fitted with a millivolt (thermopile) generator to provide power for remote activation.

CAUTION

- **Handle the gas log burner assembly by the frame only. Do not pick the unit up by the burners.**
- **Gloves are recommended when handling ceramic fiber logs to prevent skin irritation from loose fibers. Logs are fragile — handle with care.**

MAKE SURE YOU HAVE RECEIVED ALL PARTS:

Check your packing list to verify that all listed parts have been received. You should have the following:

- Unvented gas log grate/burner assembly
- Two (2) plastic bags containing crushed volcanic rock
- Installation/operating instructions
- Two (2) anchoring screws
- Ceramic fiber logs

The millivolt controlled version of this heater is the only style designed to be operated with optional devices for ON/OFF functions. The following options may be used with the millivolt controlled heater. These options are not packaged with the log set.

- Hand held Remote with receiver
- Wall thermostat with 15' wire
- Wall switch with 15' wire
- Hand held Thermostat Remote with receiver
- Thermostat sensor

Carefully inspect the contents for shipping damage. If any parts are missing or damaged, immediately inform the dealer from whom you purchased the appliance. **Do not attempt to install any part of the appliance unless you have all parts in good condition.**

WHAT YOU WILL NEED FOR INSTALLATION:

You should have the following items available before proceeding with installation:

- External regulator (for propane/LPG and 1/2 lb. natural gas systems only)
- Piping which complies with local codes
- Sediment trap (recommended)
- Screwdriver
- Tee joint.
- Pipe sealant approved for use with propane/LPG (Resistant to sulfur compounds)
- Drill with 5/32 bit
- Pipe wrench or appropriate size crescent wrench set
- Manual shutoff valve

WARNING

If the area in which the heater may be operated does not meet the required volume for indoor combustion air, combustion and ventilation air shall be provided by one of the methods described in the *National Fuel Gas Code, ANSI Z223.1/NFPA 54*, the *International Fuel Gas Code* or applicable local codes.

WARNING This appliance is for installation only in a solid-fuel burning masonry or UL127 factory-built fireplace, vent free appliance, or in listed ventless firebox enclosure. It has been design certified for these installations.
Exception: DO NOT install this appliance in a factory-built fireplace that includes instructions stating it has not been tested or should not be used with unvented gas logs.

Use manufacturer's installation and clearance requirements as defined in their manual.

The DEB Series unvented room heater is approved for installation into the following unvented fireplaces:

GCUF Series Fireboxes Magnum 32,36.

The DEB Series unvented room heater may also be installed into a Ventless Firebox Enclosure for Gas Fired Decorative Type Unvented Room Heaters per IAS Requirement No. 2-97 ANSI Z21.91-2001 (typically referred to as a "Universal Firebox"), as long as firebox hearth dimensions meet the minimum hearth dimensions shown below.

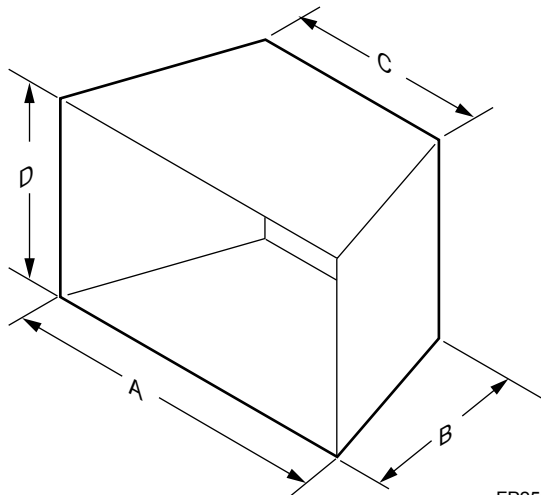

Model	A	B	C	D
DEB20	27" (686 mm)	13-1/4" (337 mm)	18" (457 mm)	17" (432 mm)
DEB24	28-1/2" (724 mm)	13-1/4" (337 mm)	22-1/4" (565 mm)	17" (432 mm)
DEB30 30" Logs	32-1/2" (826 mm)	13-1/4" (337 m)	25-1/2" (648 mm)	17" (432 mm)

Figure 1 -
Hearth Minimum Dimensions

WARNING Barriers such as the bottom of a glass door frame placed in front of a gas log set can change the air flow characteristics of the fireplace which in turn can cause the unit to overheat and malfunction.

IMPORTANT INFORMATION FOR THE INSTALLATION OF THIS GAS LOG SET

The following are guidelines for placing a gas log set in a fireplace that has a restrictive barrier along the bottom front opening of the fireplace. Some examples of barriers are glass/screen door frames and sunken/recessed fireplaces.

Height of Restriction (x)	Minimum Depth of Fireplace/Firebox
No Restriction	13Z _v "
0" to 1Z _v "	16"
Greater than 1Z _v " to 3"	16"
Greater than 3"	*

*Any barrier greater than 3" placed in front of the gas log set is not recommended by the manufacturer.

NOTE: Non combustible material such as refractory brick may be used to line the floor of the fireplace in order to raise the height of the gas log set in relation to a restrictive barrier. If the unit is raised, the minimum height dimension listed in the homeowner's manual must not be exceeded.

NOTE: If the log set is equipped with a remote receiver, a restrictive barrier may reduce the battery life by increasing the ambient temperature inside the fireplace. Placement of the receiver outside of the fireplace will extend the battery life.

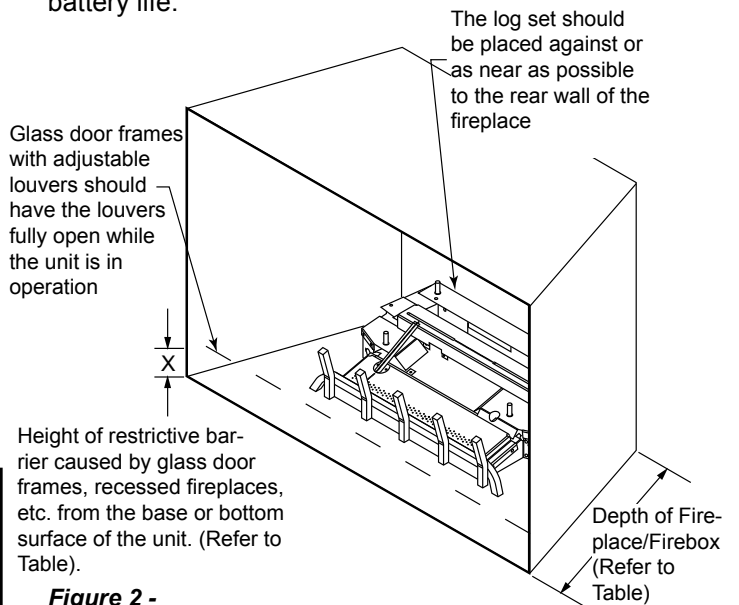

Figure 2 -
Reference Drawing of a Natural
Flame Log Set in an Enclosure

WARNING

The dimensions shown in Figures 3 through 11 and defined in the fireplace manufacturer's instructions are *minimum clearances* to maintain when installing this heater. Left and right clearances are determined when facing the front of the heater.

When heater is installed into a ventless firebox, minimum clearances, as specified by the ventless firebox manufacturer, must be met.

Follow these instructions carefully to ensure safe installation. Failure to follow instructions exactly can create a fire hazard.

Sidewall and ceiling clearances: The *sides* of the fireplace opening must be **at least 16"** from any combustible wall. The **ceiling** must be **at least 42"** from the top of the fireplace opening.

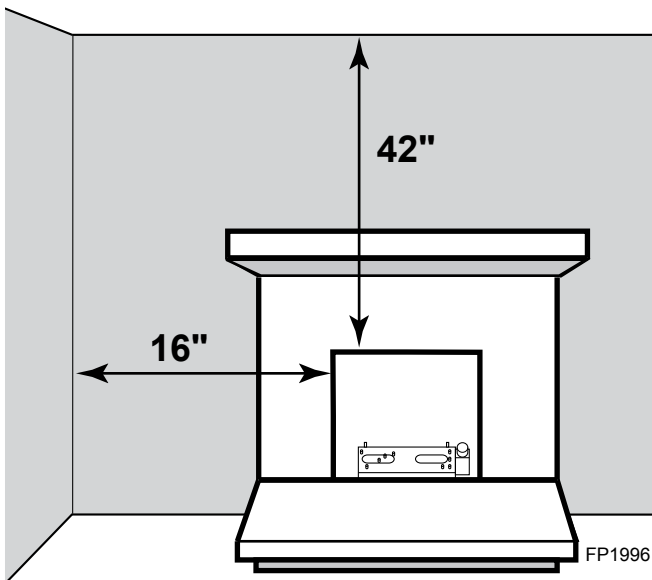

Figure 3 - Sidewall and Ceiling Clearances

Heat resistant material (minimum requirements) with no wooden mantel or other combustible projection:

To install the gas logs into a fireplace with no wooden mantel, shelf or other combustible projection above the fireplace opening, measure the heat resistant material height, *per Figure 4*, then see **TABLE A**.

Heat resistant materials such as slate and marble must be **at least 1/2"** thick. **Sheet metal should not be installed onto combustible material.**

IMPORTANT: If you cannot meet these minimum clearances you must operate the heater with chimney flue damper open. Refer to "Installing Vented Applications" found on page 17.

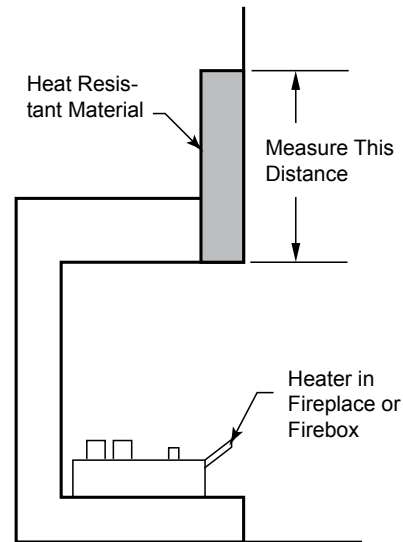

Figure 4 - Measure Heat Resistant Material FP2795

Table A - Heat Resistant Material Requirements with No Mantel or Combustible Projection

Heat Resistant Material Measurement	Requirements for Safe Installation	
	DEB20	DEB24/30
12" or more	Hood not required	
8" or less than 12"	Hood not required	Extend heat resistant mat'l to 12" or install hood <i>Figure 4</i>
Less than 8"	Extend heat resistant material to at least 8" and install hood. <i>Figure 4</i>	Extend heat resistant mat'l to at least 8" and install hood. <i>Figure 4.</i> OR , extend heat resistant material to a height of at least 12"

Heat resistant material (minimum requirements) with wooden mantel or other combustible projection:

To install the heater with a wooden mantel, shelf or other combustible projection above, first measure the heat resistant material shown in *Figure 5*, then refer to Table B.

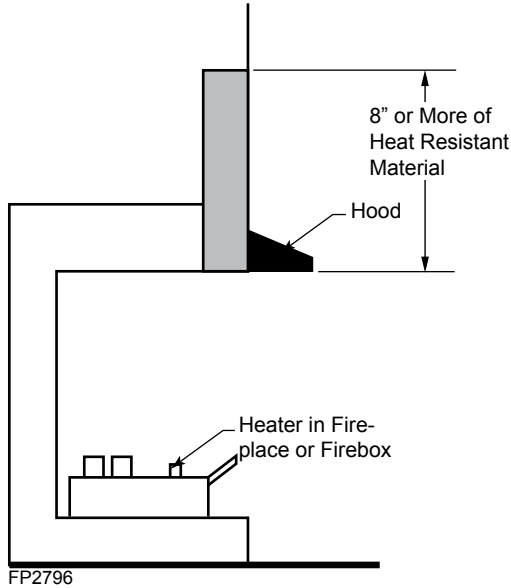

Figure 5 - Measure Heat Resistant Material for Mantel

Table B - Heat Resistant Material Heights and Mantel Location

Heat Resistant Material Measurement	Requirements for Safe Installation with Wood Shelf or Other Combustible Projection	
	DEB20	DEB24/30
12" or more	Hood not required. Observe profiles (side elevations) shown in Fig. 6	Hood not required. Observe profile (side elevations) shown on Page 10, Figure 8
8" to less than 12"	Install hood and observe profiles shown on Page 10, Figure 8, OR, extend heat resistant material to at least 12" and observe profiles shown in Fig. 6.	Install hood and observe profiles shown in Figure 6, OR, extend heat resistant material to at least 12" and observe profiles shown on Page 10, Fig. 8
Less than 8"	Extend heat resistant mat'l to at least 8", install hood and observe profiles shown in Fig. 7, OR extend heat resistant material to at least 12" and observe profiles shown in Fig. 7.	Extend heat resistant material to at least 8", install hood and observe profile shown in Fig. 6; OR extend resistant material to at least 12" and observe profiles shown on Page 10, Fig. 8.

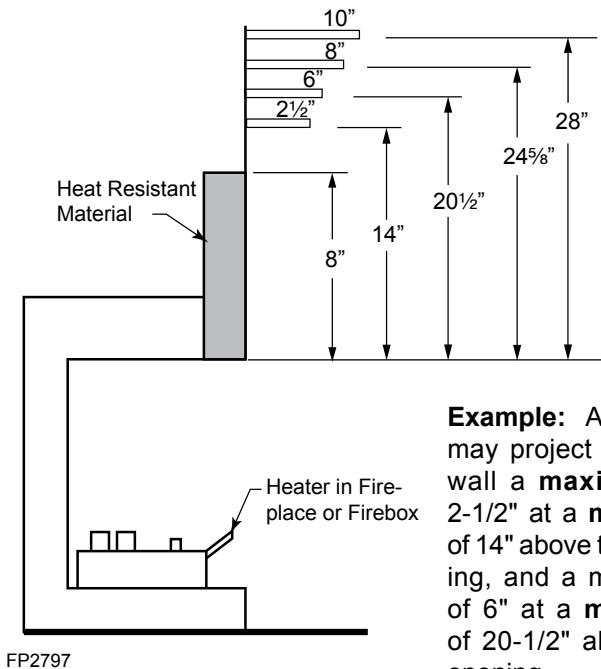

Figure 6 - DEB20 Minimum Mantel Clearance with No Hood

Example: A mantel may project from the wall a **maximum** of 2-1/2" at a **minimum** of 14" above the opening, and a maximum of 6" at a **minimum** of 20-1/2" above the opening.

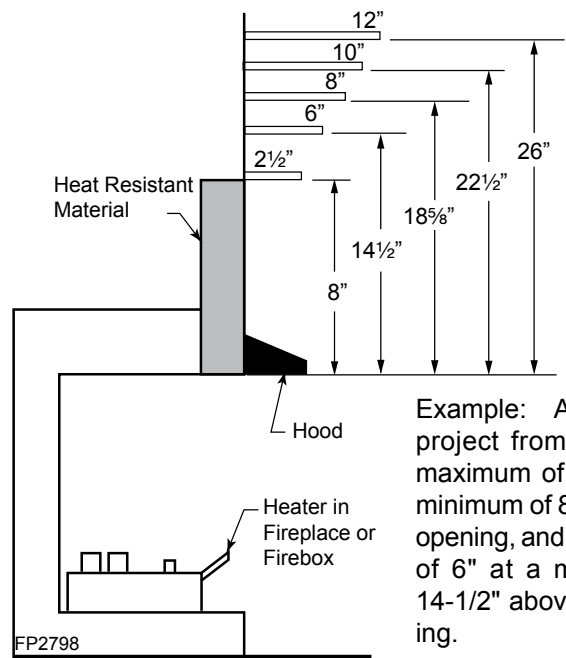

Figure 7 - All Models Minimum Mantel Clearance with a Hood

Example: A mantel may project from the wall a maximum of 2-1/2" at a minimum of 8" above the opening, and a maximum of 6" at a minimum of 14-1/2" above the opening.

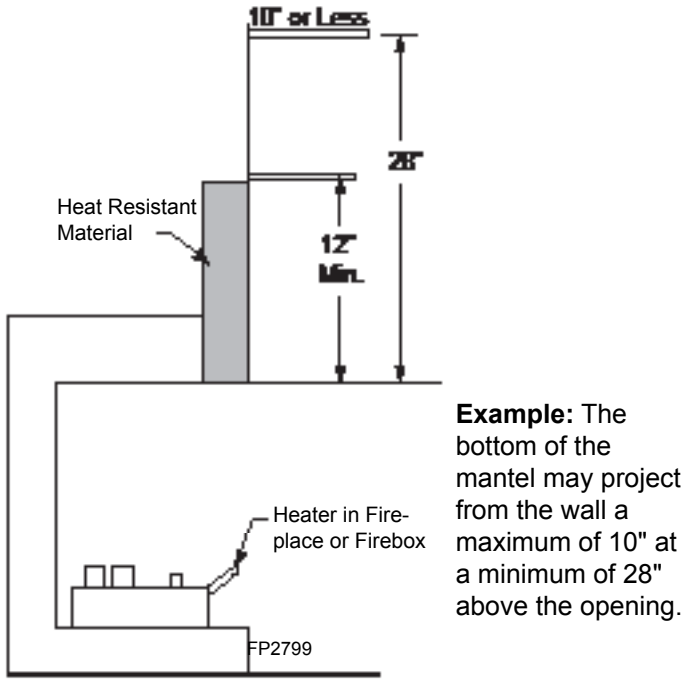

Figure 8 -
DEB24/30 Minimum Mantel Clearance with No Hood

Example: The bottom of the mantel may project from the wall a maximum of 10" at a minimum of 28" above the opening.

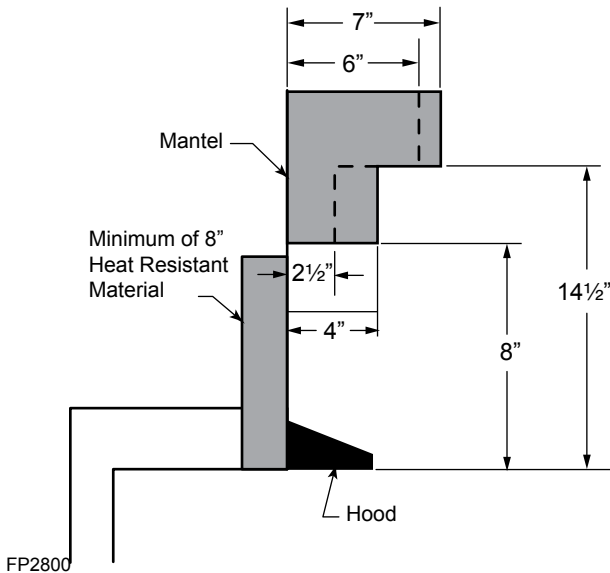

Figure 9 -
DEB24/30 Example of Unsafe Installation - Minimum Mantel Clearance with No Hood

Figure 9 is an example of an unsafe mantel installation. This mantel projects 4" at 8" above the opening, exceeding the maximum acceptable distance of 2-1/2". The mantel also projects 7" at 14-1/2" above the opening, exceeding the maximum acceptable distance of 6".

If your mantel profile is unsafe, you may either:

- Raise the mantel to an acceptable height
- OR**
- Remove the mantel

The gas log heater must be installed at least 5" above any combustible flooring material, such as carpeting or tile, which is closer than 14" to the base of the fireplace. The minimum distance must be maintained from the top surface of carpeting, tile, etc. *Figure 10*

OR,

The gas log heater may be installed nearer to the floor if a minimum of 14" of noncombustible material such as slate or marble is installed between the base of the fireplace and the combustible flooring. *Figure 11*

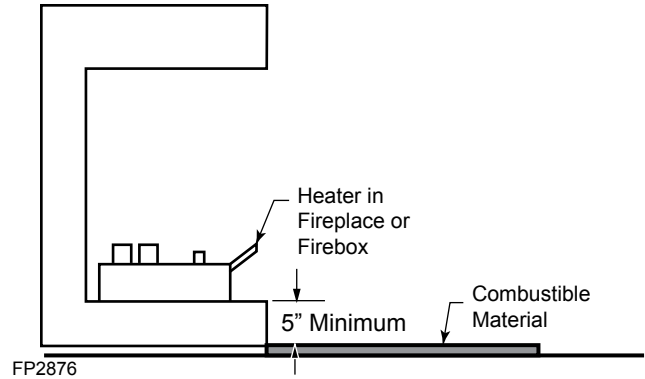

Figure 10 -
Minimum Clearance above Combustible Flooring

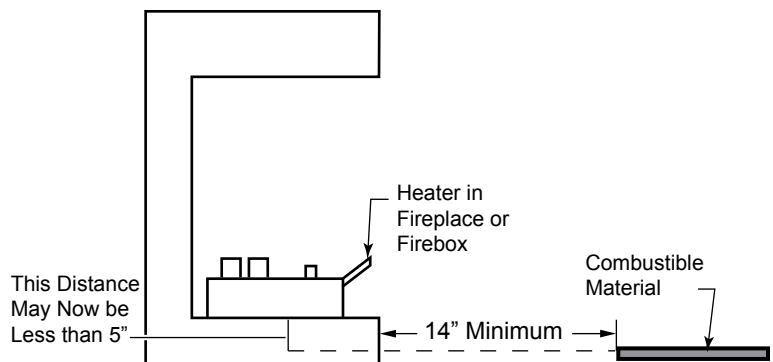

Figure 11 -
Minimum Clearance above Combustible Floor with Non-combustible Material Installed at Base of Fireplace

BEFORE FULLY INSTALLING THE UNIT:

- Turn **OFF** the gas supply to the fireplace or firebox.
- Seal any fresh air vents and/or ash clean-out doors located on the floor or wall of the fireplace. If left unsealed, drafting may cause pilot outage or sooting. Use a heat resistant sealant. **Do not seal the chimney flue damper.**

WARNING Before installing in a solid fuel burning fireplace, The chimney flue and firebox must be cleaned of soot, creosote, ashes and loose paint by a qualified chimney cleaner.

INSTALLING VENTED APPLICATIONS

Manual and millivolt controlled gas logs may be installed as a vented decorative log set in compliance with ANSI Z21.60 and National Fuel Gas Code, Section 6.6. **Since, the gas logs are operated with the damper open, non-combustible material and minimum mantel requirements do not apply.**

WARNING This appliance is for installation only in a solid fuel burning fireplace (masonry fireplace or manufactured fireplace) with a working flue and constructed of noncombustible material.
Exception: DO NOT install this appliance in a factory-built fireplace that includes instructions stating that it has not been tested or should not be used with unvented gas logs. This log set may be installed as a vented log set.

BEFORE INSTALLING THE APPLIANCE:

- Turn off gas supply to fireplace or firebox.
- Have the fireplace floor and chimney professionally cleaned to remove ashes, soot, creosote or other obstructions. Have this cleaning performed annually after installation.
- Seal any fresh air vents or ash clean-out doors located on floor or wall of fireplace. If not, drafting may cause pilot outage or sooting. Use a heat-resistant sealant.

Install and operate the appliance as directed in this manual.

DAMPER STOP INSTALLATION

A damper stop must be provided with the unit. Contact your dealer to obtain one. The damper stop must be installed as shown in *Figure 12* to prevent full closure of the fireplace damper blade and provide a minimum 29 square inch flue opening.

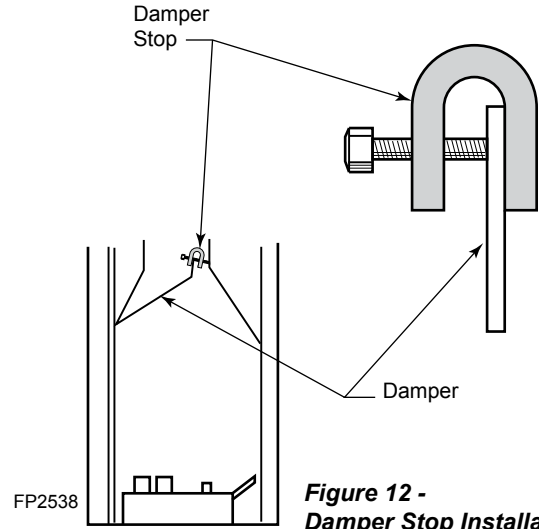

Figure 12 - Damper Stop Installation (See Warning)

WARNING The fireplace and gas logs function as a system. If the fireplace is spilling into the room (check with a match or a smoke stick), reposition the damper clamp until a positive draft is obtained by opening the damper. If negative pressure in home prevents having a positive draft, contact your dealer for assistance.

PLACE AND SECURE APPLIANCE

WARNING You must secure the gas log heater to the fireplace floor. If not, the entire unit may move when you adjust the controls. Movement of unit may cause shifting of the gas logs which leads to sooting and improper burning. Grate movement could cause a gas leak.
Special care is required if you are installing the unit into a sunken fireplace. You must raise the fireplace floor to allow access to gas log controls. This will insure adequate air flow and guard against sooting. Raise the fireplace floor using noncombustible materials, as described in *Placement in a Fireplace with Restrictive Barrier* on Page 7.

ASSEMBLY PROCEDURE:

1. Center the gas log unit in the fireplace or firebox. Make certain the front feet of the grate sit inside the front edge of the fireplace or firebox.
2. Anchor holes are located on the right and left sides of the unit. After centering the grate correctly, mark the hole positions on the fireplace/firebox floor. Drill two (2) 5/32" diameter holes approximately 1-1/2" deep.
3. Anchor the grate to the fireplace/firebox floor using the screws provided. *Figure 13*

Proper installation of the grate is essential to prevent any movement of the gas logs and controls during operation.

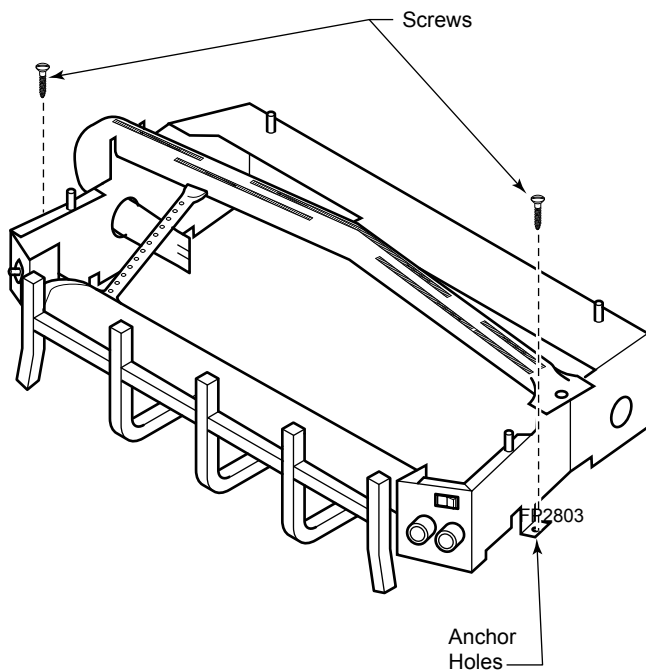

Figure 13 - Secure Heater to Floor of Fireplace or Firebox

CONNECT THE GAS

NOTICE: A qualified gas appliance installer must connect the heater to the gas supply. Consult all local codes.

CAUTION

Use new black iron or steel pipe. Internally tinned copper or copper tubing can be used per National Fuel Code, section 2.6.3, providing gas meets hydrogen sulfide limits, and where permitted by local codes. Gas piping system must be sized to provide minimum inlet pressure (Listed on Data Plate) at the maximum flow rate (BTU/Hr). Undue pressure loss will occur if the pipe is too small.

A manual shutoff valve must be installed upstream of the appliance. Union tee and plugged 1/8" NPT pressure tapping point should be installed upstream of the appliance. *Figure 14*

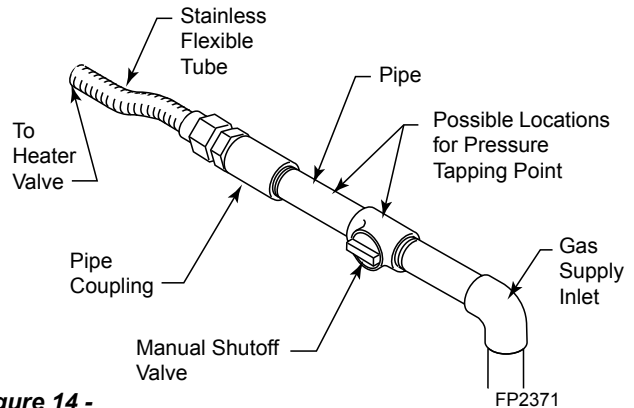

Figure 14 - Gas Connection

WARNING

CHECK GAS TYPE: The gas supply must be the same as stated on the heater's rating plate. If the gas supply is different, **DO NOT INSTALL THE HEATER.** Contact your dealer for the correct model.

Always use an external regulator for all propane/LPG heaters and high pressure one to two-pound systems only, to reduce the supply tank pressure to a maximum of 13" w.c. This is in addition to the internal regulator in the heater valve.

WARNING Connecting directly to an unregulated propane/LPG tank can cause an explosion.

CHECK GAS PRESSURE

The heater gas inlet connection is a 3/8" NPT at the valve. On all control type units, the inlet connection is on the right side of unit. To connect from the opposite side, route the pipe around the back portion of the unit.

When tightening up the joint to the valve, hold the valve securely to prevent movement.

Test all gas joints from the gas meter to the heater valve for leaks using a gas analyzer or soap and water solution after completing connection. **DO NOT USE AN OPEN FLAME.**

Check the gas pressure with the appliance burning and the control set to **HIGH**.

MANUAL CONTROL

Figure 15

The pressure regulator is preset and locked to discourage tampering. If the pressure is not as specified, replace the regulator with the correct part from the parts list in this manual.

Remove 1/8" NPT plug, located on side of regulator body. Install fitting and tubing to pressure gauge. After taking pressure reading, reinstall test plug. Check for gas leaks.

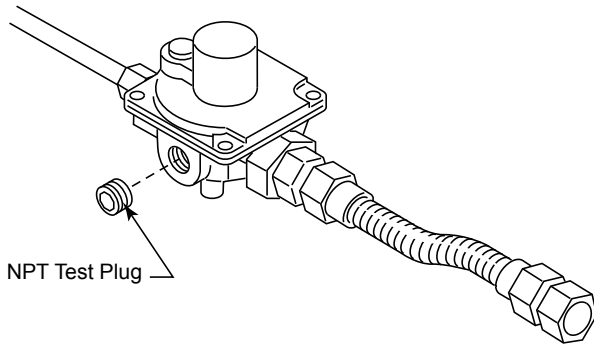

Figure 15 - Manual Control Pressure Test Point Location

MILLIVOLT CONTROL

Figure 16

The valve regulator controls the burner pressure which should be checked at the pressure test point.

Turn captured screw counter clockwise two or three turns and then place tubing to pressure gauge over test point (Use test point "OUT" closest to control knob). After taking pressure reading, be sure and turn captured screw clockwise firmly to re-seal. Do not over torque. Check for gas leaks.

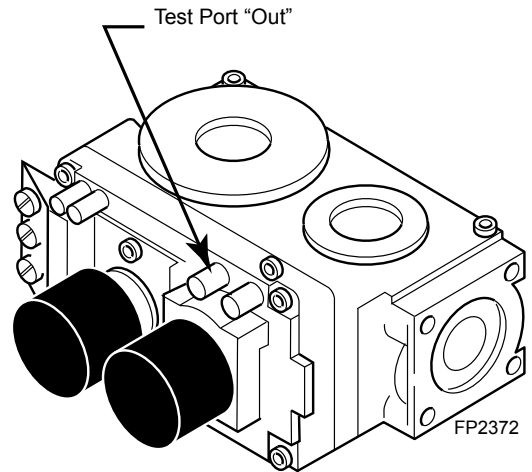

Figure 16 - Millivolt Control Pressure Test Point Location

WARNING

Label all wires prior to disconnection when servicing controls.

Wiring errors can cause improper and dangerous operation.

Verify proper operation after servicing.

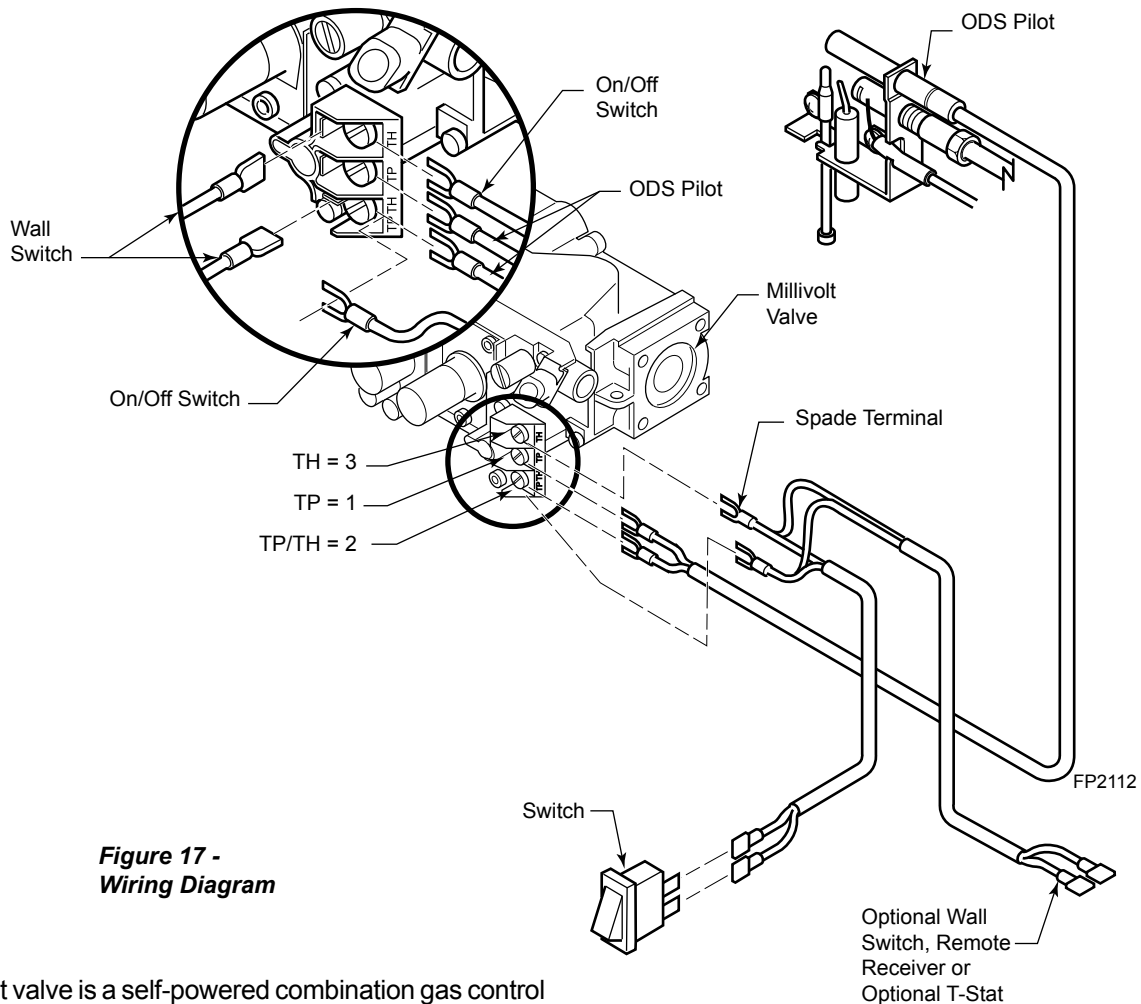

**Figure 17 -
Wiring Diagram**

The millivolt valve is a self-powered combination gas control **THAT DOES NOT REQUIRE 110 VAC TO OPERATE.**

CONNECT OPTIONAL WALL SWITCH OR THERMOSTAT

1. Use 18 awg, two-wire cable, 15 feet maximum length.
2. At one end of the cable, connect both wires to the wall switch or thermostat. At the other end, connect one wire to TP/TH and one wire to TH, or connect the wall switch/thermostat to the two male (0.25") terminals on the left side of the unit. The color of the wires does not matter.

CONNECT REMOTE RECEIVER

Connect the connectors to the two (2) .25" male connectors located on the right side when facing the unit. *Figure 18*. Do not allow the wire to touch the grate or burners.

NOTE: Heat reduces battery life. You can protect the receiver and extend battery life by mounting the receiver in a wall or other location outside the fireplace.

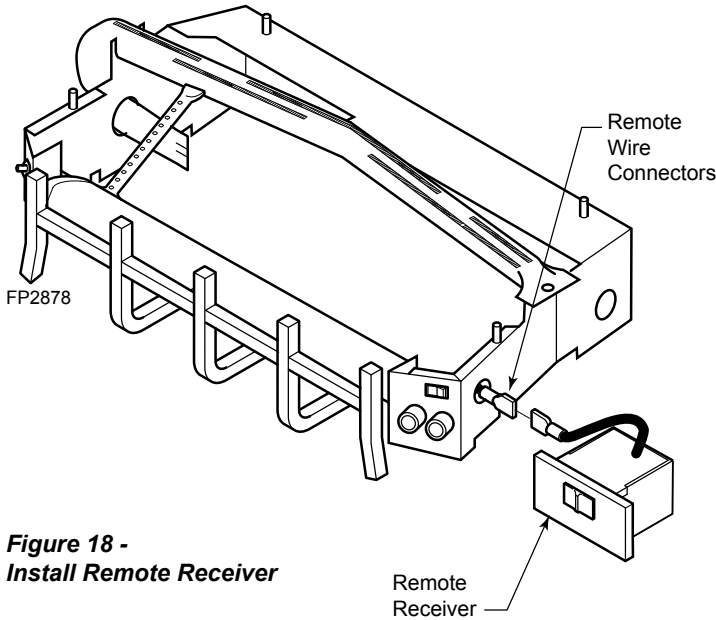

Figure 18 - Install Remote Receiver

INSTALL T-STAT SENSOR

OPTION SOLD SEPARATELY

1. Remove metal bracket and label from box.
2. Peel away the paper backing on the label. Align holes in label with holes on the bracket. Right side of label should flush with right side of bracket. *Figure 19*. Press label firmly and smoothly to bracket.
3. Using Phillips screwdriver, install t-stat sensor to bracket with two screws provided. *Figure 20*. Make sure the thermo bulb wire is at the bottom of t-stat sensor.
4. Plug in wiring harnesses to back of t-stat sensor. *Figure 20*.

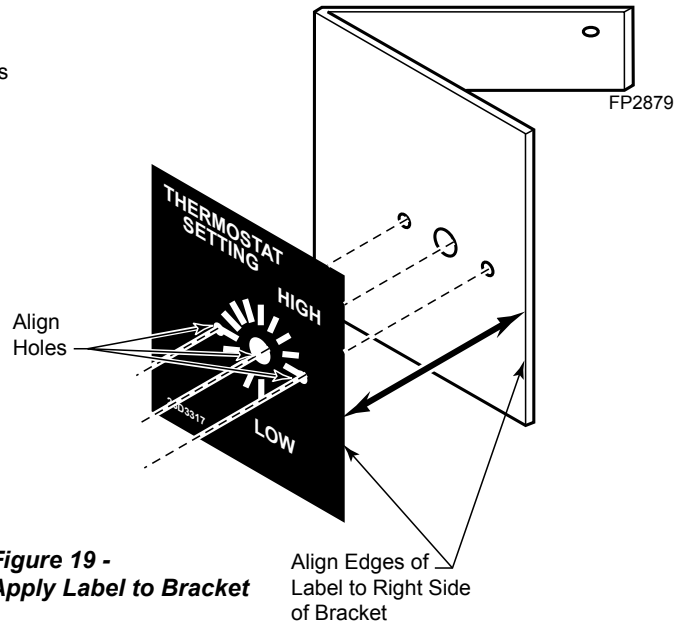

Figure 19 - Apply Label to Bracket

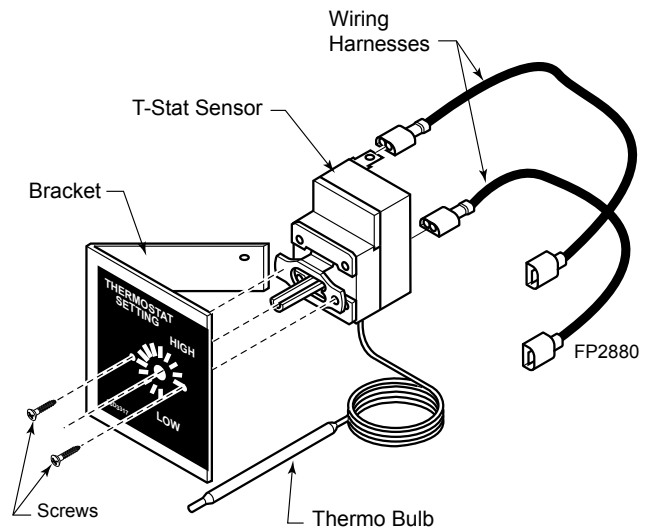
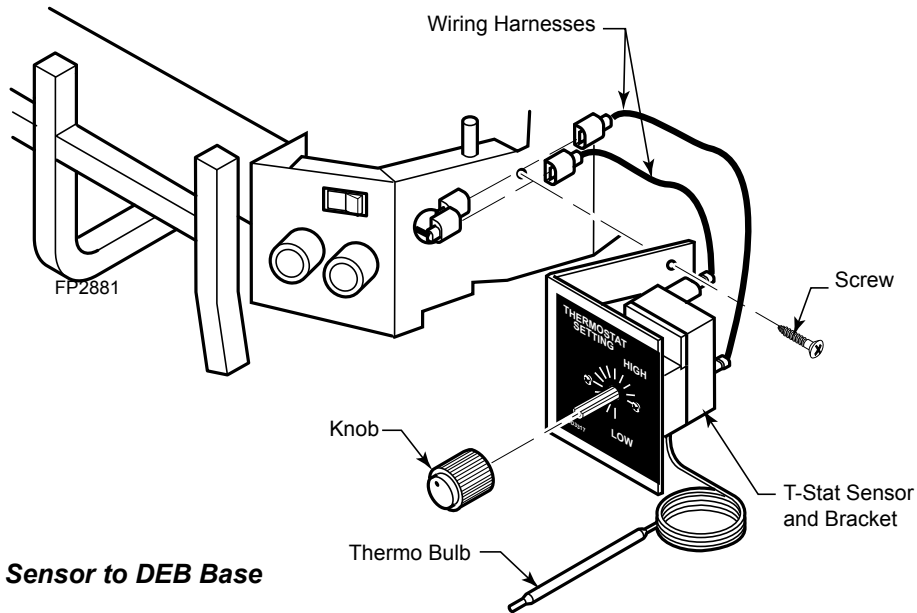
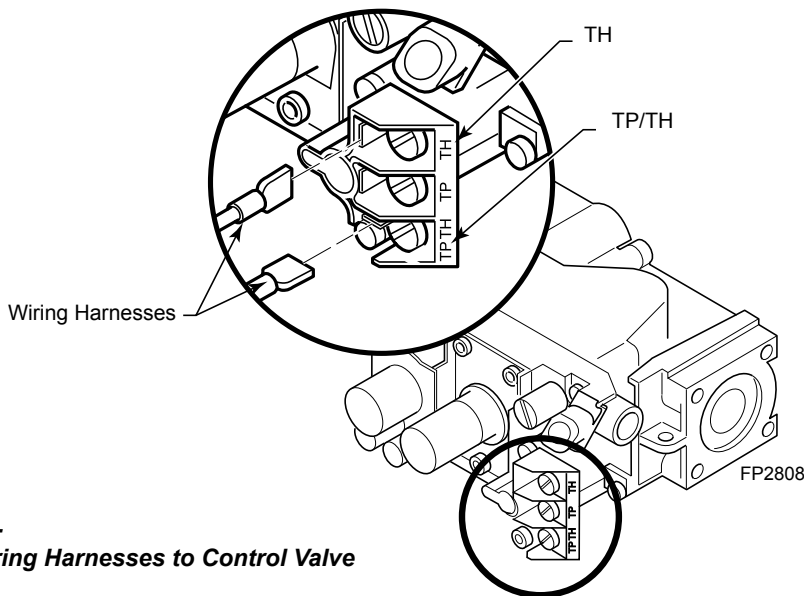

Figure 20 - Install T-Stat Sensor and Wiring Harnesses

5. Route wiring harnesses through large hole on side of unit. Mount bracket to side of unit with screw provided. *Figure 21*
6. Attach wiring harness to either TP/TH and TH on control valve or to existing wiring harness with two (2) 0.250" male spade terminals for remote or t-stat option. *Figures 21 and 22.*
7. Install knob to shaft of t-stat sensor. *Figure 21.*
8. Place thermo bulb in front of the firebox for incoming air.



**Figure 21 -
Install T-Stat Sensor to DEB Base**



**Figure 22 -
Attach Wiring Harnesses to Control Valve**

OPERATION OF THERMOSTAT SENSOR

1. Follow millivolt lighting instructions on lighting plate attached to unit or in homeowner’s manual.
2. With control knob in the “ON” position make sure the ON/OFF switch is in the “OFF” position. *Figure 23*
3. The unit is now being controlled by the thermostat sensor. The sensor will now cycle the burners on and off. You can adjust how often the unit cycles by turning the control knob on the sensor.

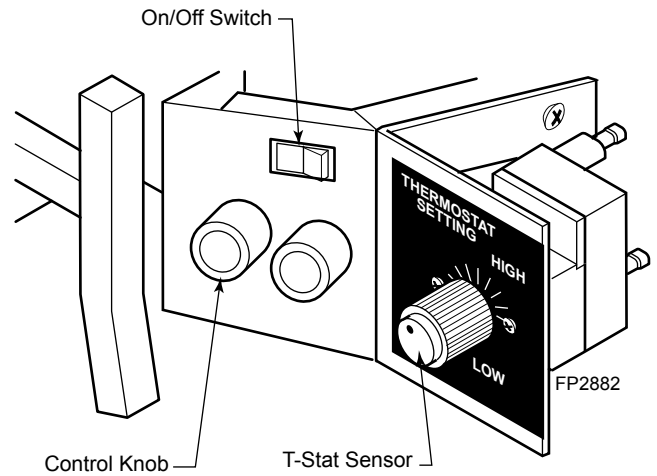

Figure 23 - Control Knob in “ON” Position and ON/OFF Switch in “OFF” Position

CHECKING SYSTEM OPERATION

The millivolt system and individual components may be checked with a millivolt meter having a 1-1000 mV range. Conduct each check shown in chart by connecting meter test leads to terminals as indicated.

A. Complete Millivolt System Check

(“A” Reading - Thermostat contacts CLOSED - Control knob “ON” - Main burner should turn ON)

1. If reading is more than 175 millivolts and the automatic valve still does not come on, replace the control.
2. If the closed circuit reading (“A” reading) is less than 175 millivolts, determine cause for low reading, proceed to Section B.

B. Thermopile Output Reading Check

(“B” Reading - thermostat contacts OPEN - Main burner OFF)

1. Check gas pressure to the unit. If gas pressure is within minimum and maximum on data plate, then check pilot voltage, 500 millivolts minimum. If the minimum millivolt reading is not obtainable, replace pilot.

Check Test	To Test	Connect Meter Leads To Terminals	Switch or Thermostat Contacts	Meter Reading Should Be
A	Complete System	TP/TH and TH	Closed	Minimum 175
B	Thermopile Output	TP and TP/TH	Open	Minimum 500

WARNING

The positioning of the logs are critical to the safe and clean operation of this heater. Sooting and other problems may result if the logs are not properly and firmly positioned in the appliance. Never add additional logs or embellishments such as pine cones, vermiculite or rock wool to the heater. Only use the logs and EB-RW (rock wool) supplied with the unit.

Failure to position the parts in accordance with diagrams below or to use only parts specifically approved for this heater may result in property damage or personal injury.

Before you begin — This unit is supplied with five or six ceramic fiber logs. Do not handle these logs with your bare hands. **Always wear gloves to prevent skin irritation from ceramic fibers.** After handling the logs, wash your hands gently with soap and water to remove any traces of fibers.

PLACE LOGS ON GRATE

Figures 24 and 25

NOTE: Model DEB20 has 5 logs and models DEB24 and DEB30 have 6 logs.

1. Install back log (#1) on two pins located near the back of base. Check log position and stability.
2. Install right center log (#2) on pins located near right front of base and center of base.

NOTE: The #2 log is a heat shield for the control valve. It is critical that this log is sitting in its pin placement and completely down with the front nose of the embers placed below the front burner. If the #2 log is not placed properly it could cause damage to the control valve and wiring.

3. Install left center log (#3) on pin located near left front of base and on top of right center log (#2).
4. Install middle front log (#4) in front of center log. Make sure bottom of log is resting on the center of grate. Do not let log #4 contact the front burner.

5. **DEB 24 and DEB 30 only:** Rest right end of left front log (#5) on log #3 and the top of left front log on log #1.
6. Place back end of top center log (#5) on recessed area of back log (#1). Cross log #6 over log #2 and rest right extension on grate. Log #6 should fit on pin on center log #3.

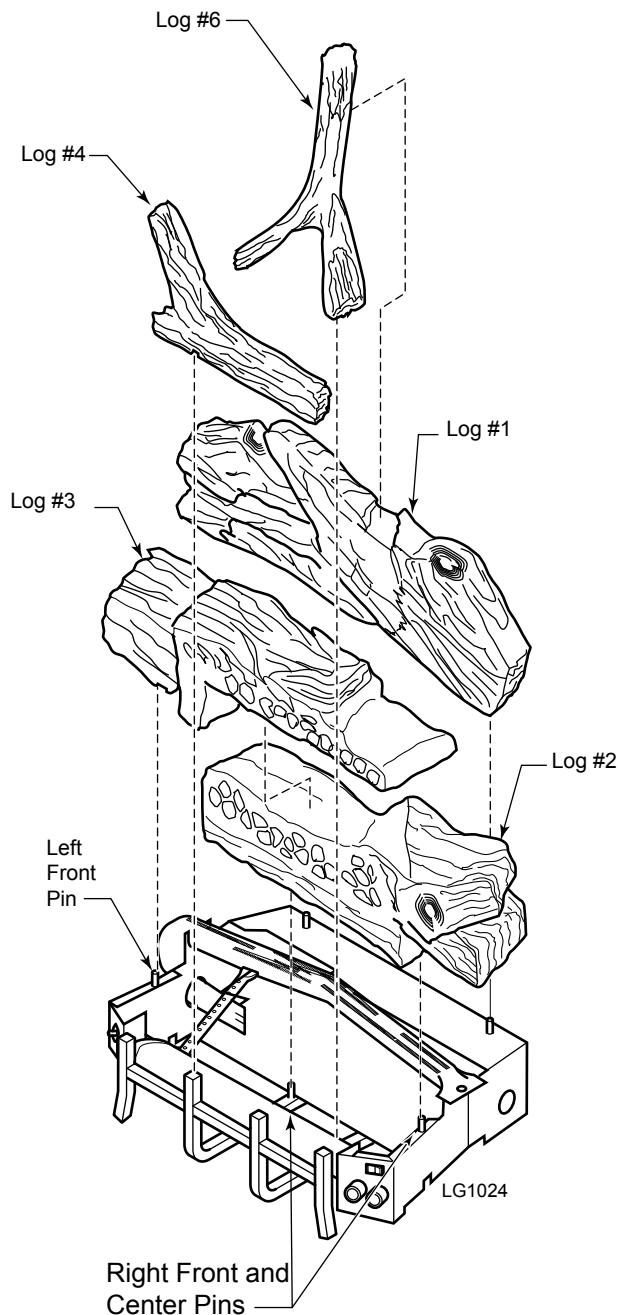
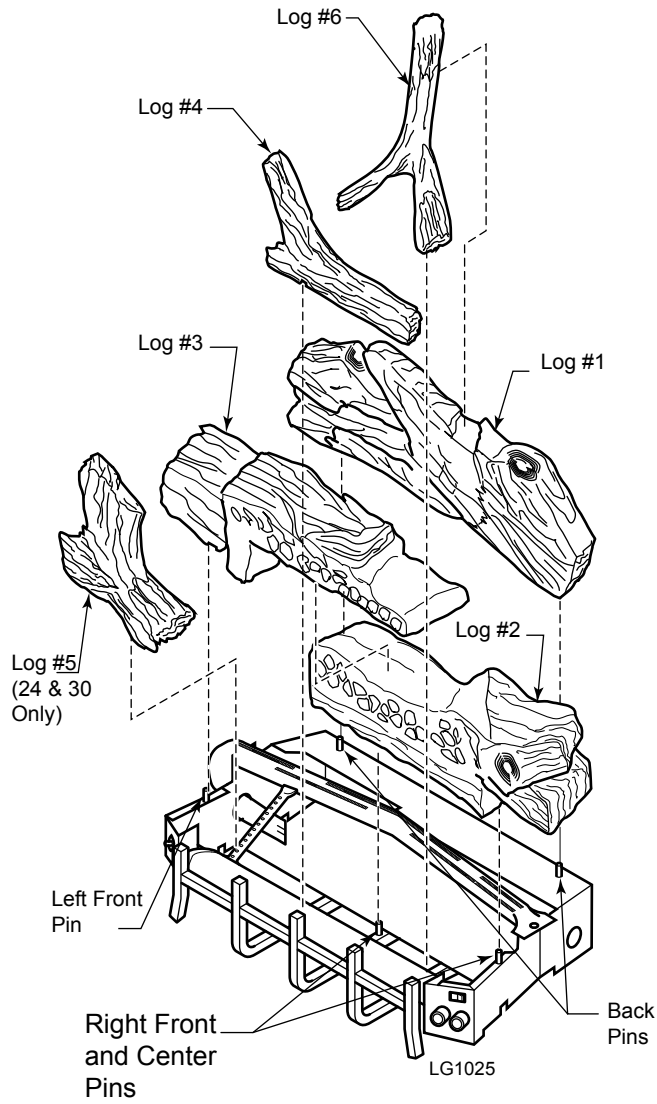

Figure 24 - Place Logs on Grate (DEB20)



**Figure 25 -
Place Logs on Grate
(DEB24/30)**

PLACE THE DECORATIVE ROCK

CAUTION

DO NOT sprinkle volcanic rock on the logs, around the pilot, or on or near burners. This may cause sooting. Place volcanic rock only on the floor of the fireplace.

During initial operation of the new heater, burning logs will give off a paper burning smell and orange flames will be present. Simply open the windows for a few hours to vent the odor.

Flames from the pilot, front and rear burner should be visually checked as soon as the heater is installed. In addition, periodically check the flames visually during operation.

MILLIVOLT CONTROL

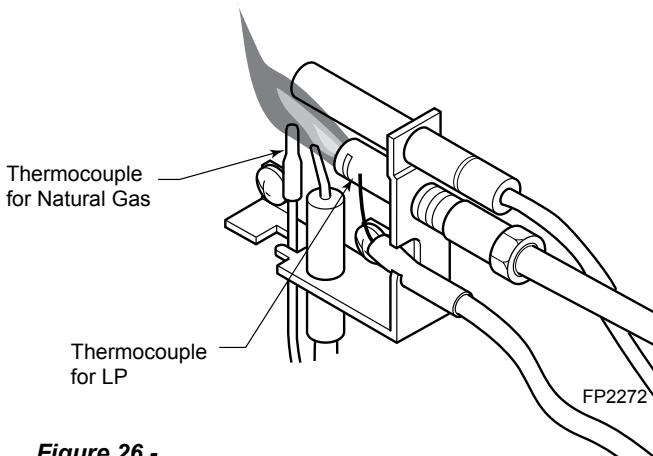

Figure 26 - Correct Pilot Flame Appearance

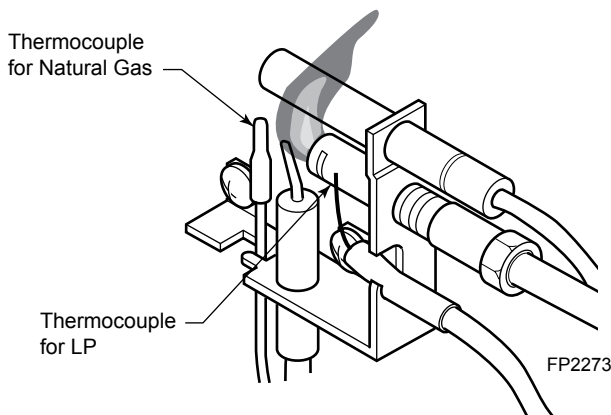

Figure 27 - Incorrect Pilot Flame Appearance

CHECK THE PILOT FLAME

The pilot flame must always be present when the heater is in operation. It should just touch the top of the thermocouple tip for natural. Refer to Figures 26 and 28 for correct pilot flame appearance.

If the pilot flame does not touch the thermocouple, then the main burner cannot function reliably. Refer to Figures 27 and 29 for incorrect pilot flame appearance.

MANUAL & HI/LO CONTROL

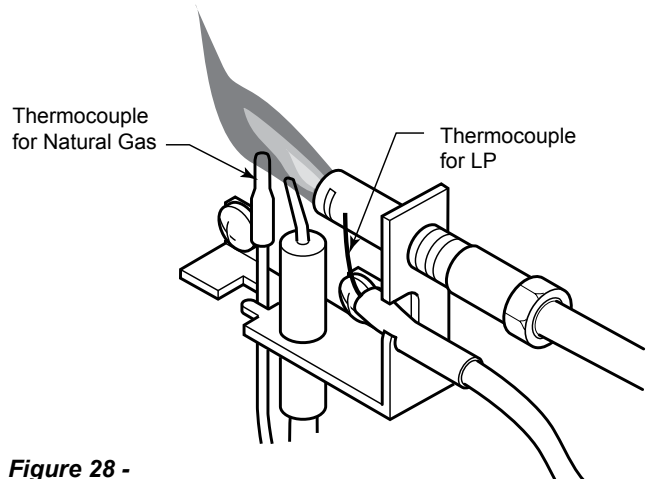

Figure 28 - Correct Pilot Flame Appearance

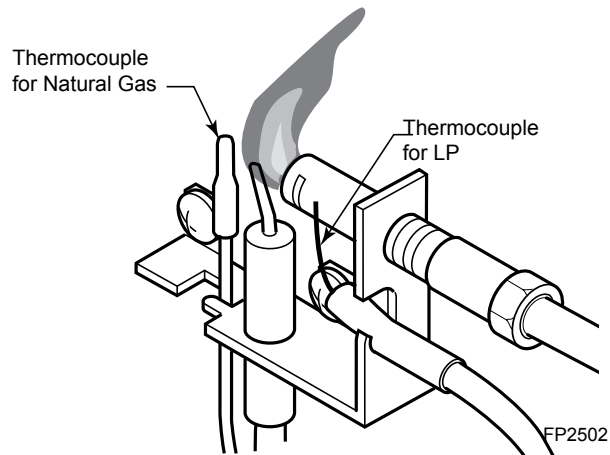
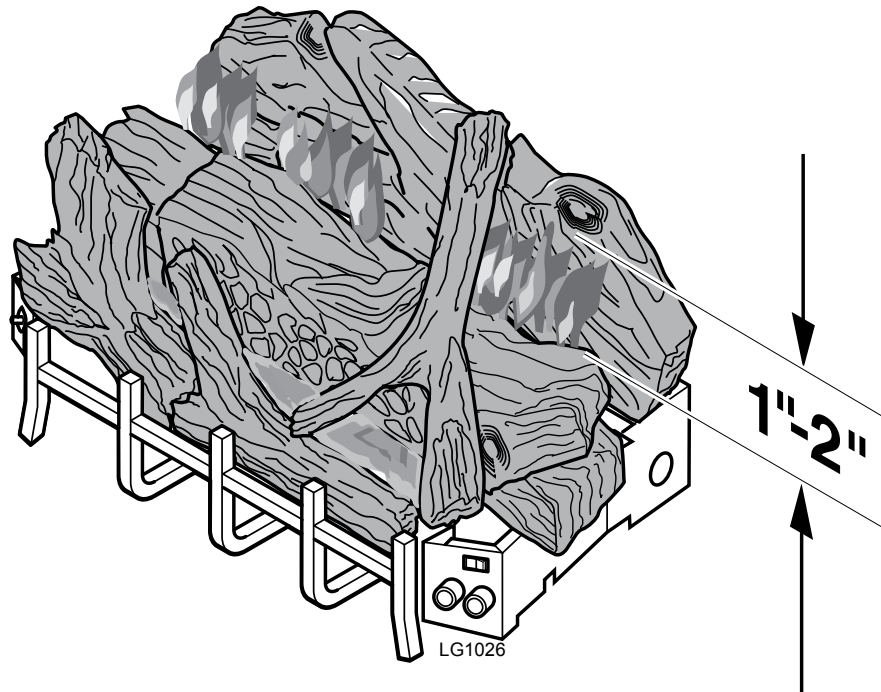

Figure 29 - Incorrect Pilot Flame Appearance

In normal operation at full rate after 15 minutes, the following flame appearances should be observed:



**Figure 30 -
Correct Rear Flame Appearance**

The left and right rear flames should be yellow and extend 1"-2" above the mid log top surfaces. The yellow flames should **not** contact the logs. There should be glowing embers on the front burner.

NOTE: The front flames and embers will be an opaque orange color during the burn off time.

OPERATING INSTRUCTIONS

Avoid any drafts that alter burner flame patterns. Do not allow fans to blow directly into the fireplace. Do not place a blower inside the burn area of the firebox. Ceiling fans may create drafts that alter flame patterns. Sooting and improper burning will result.

During manufacturing, fabricating and shipping, various components of this appliance are treated with certain oils, films or bonding agents. These chemicals are not harmful, but may produce annoying smoke and smells as they are burned off during the initial operation of the appliance, possibly causing headaches or eye or lung irritation. *This is a normal and temporary occurrence.*

The initial break-in operation should last two to three hours with the burner at the highest setting. Provide maximum ventilation by opening windows or doors to allow odors to dissipate. Any odors remaining after this initial break-in will be slight and will disappear with continued use.

This appliance must not be used with glass doors in the closed position. This can lead to pilot outages and severe sooting outside the fireplace. Page 7, *Figure 2*

FOR YOUR SAFETY, READ BEFORE LIGHTING**WARNING**

If you do not follow these instructions exactly, a fire or explosion may result causing property damage, personal injury or loss of life.

- A. This appliance is equipped with a piezo ignition device which lights the pilot. If piezo is not working properly, refer to "Match Lighting" instructions on *Page 26*.
- B. BEFORE OPERATING smell all around the appliance area for gas. Be sure to smell next to the floor because some gas is heavier than air and will settle on the floor.

WHAT TO DO IF YOU SMELL GAS:

- Do not attempt to light any appliance.
 - Do not touch any electric switch; do not use any phone in your building.
 - Immediately call your gas supplier from a neighbor's phone. Follow the gas supplier's instructions.
 - If you cannot reach your gas supplier, call the fire department.
- C. Use only your hand to push in, or turn the gas control knob. Never use tools. If the knob will not push in or turn by hand, don't try to repair it. Call a qualified service technician. Force or attempted repair may result in a fire or explosion.
 - D. Do not use this appliance if any part of it has been under water. Immediately call a qualified service technician to inspect the appliance and to replace any part of the control system and any gas control that has been under water.

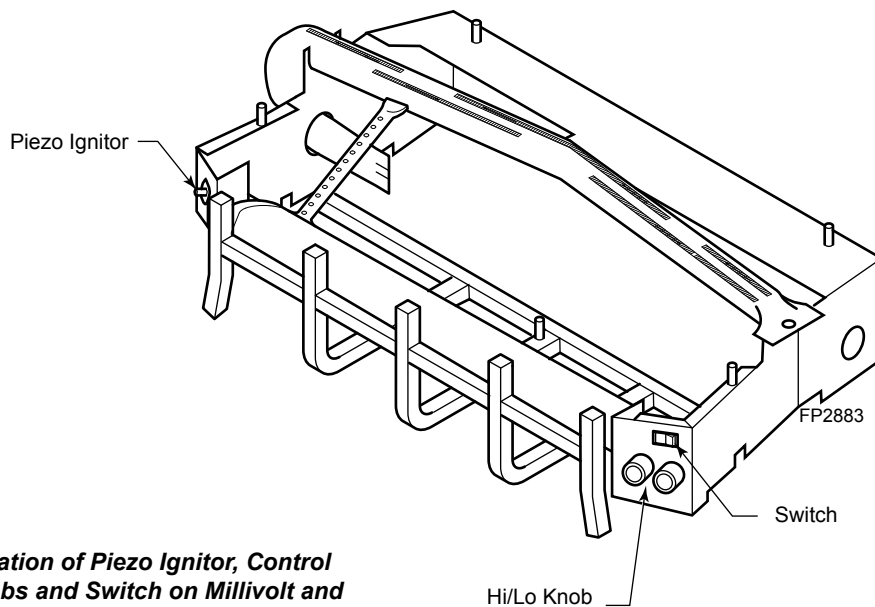

Location of Piezo Ignitor, Control Knobs and Switch on Millivolt and Manual Units

MANUAL CONTROL LIGHTING INSTRUCTIONS

- STOP!** Read the safety information.
- Make sure the manual shutoff valve is fully open.
- This heater is equipped with an ignition device (piezo) which automatically lights the pilot.
- Refer to Page 23 for the location of the piezo ignitor and control knob. Push in gas control knob slightly and turn control knob clockwise  to the OFF position.

NOTE: Knob cannot be turned to OFF unless knob is pushed in slightly. Do not force.

- Wait 5 minutes to clear out any gas. Then smell for gas, including near the floor. If you smell gas **STOP!** Follow the instructions under "What to Do if You Smell Gas", Page 23. If you do not smell gas, go to the next step.
- From OFF position, push in gas control knob slightly and turn counterclockwise  to the IGN position. Figure 31. Push in and hold control knob for 5 seconds.

NOTE: If you are running the heater for the first time, it will be necessary to press in the control knob for 30 seconds to allow air to bleed out of the gas piping.

- With the control knob pushed in, push and release the piezo ignitor button to light the ODS pilot. The pilot is located on the left side of the heater, behind the middle log and in front of the back log. If piezo ignitor does not light the pilot, refer to "Match Lighting Instructions", Page 26.
- Hold the control knob in for an additional 10 seconds to prevent the ODS pilot from shutting off the gas while the thermocouple is warming up.
- Release the control knob.

- If the knob does not pop out when released, stop and immediately call your service technician or gas supplier.
- If the ODS pilot will not stay lit after several tries, push and turn the gas control knob clockwise  to OFF and wait 15 seconds. Repeat steps 6 through 9.

- Push in control knob and turn counterclockwise  to the HIGH setting. At this location the control knob will pop out when positioned correctly. The knob can now be positioned at any position between HIGH and LOW. Figures 32 and 33

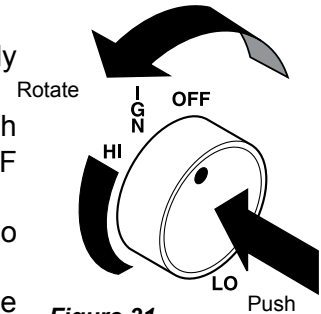

Figure 31 -
IGN Position

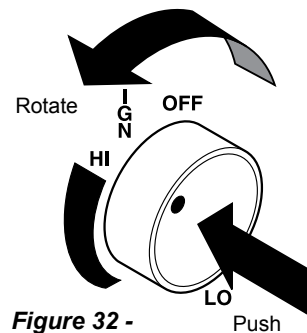

Figure 32 -
HIGH Position

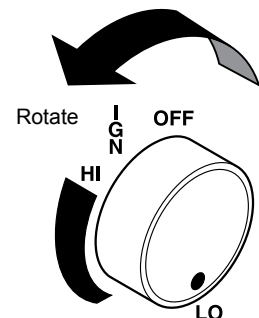



Figure 33 -
LOW Position



WARNING

Wait 30 seconds before readjusting the heater when the control knob has been turned down to a lower setting.

TO TURN OFF GAS TO HEATER

- Turn control knob clockwise  to **OFF** position to completely shut off the heater.
- If applicable: Turn off all electric power to the heater.

MILLIVOLT CONTROL LIGHTING INSTRUCTIONS

1. **STOP!** Read the safety information label.
2. Make sure the manual shutoff valve is fully open.
3. This gas log set is equipped with an ignition device (piezo) which automatically lights the pilot. If piezo ignitor does not light the pilot, refer to instructions for *Match Lighting Instructions, Page 26*.
4. Turn gas control knob clockwise  to the OFF position, set thermostat to lowest setting and turn ON/OFF switch to OFF position.
5. Wait (5) minutes to clear out any gas. Then smell for gas, including near the floor. If you smell gas, **STOP!** Follow *What to Do if You Smell Gas, Page 23*. If you don't smell gas, go to next step.
6. From OFF position, turn the gas control knob counterclockwise  to IGN position. Push in control knob for 5 seconds. **NOTE: If you are running the heater for the first time, it may be necessary to press in the control knob for 30 seconds or longer to allow air to bleed out of the gas piping.**
7. With the control knob pushed in, push in and release the piezo ignitor button to light the pilot.
8. Continue pushing the control knob in for a further 60 seconds to prevent the flame detector from shutting off the gas while the probe is warming up. Release the control knob.
9. Turn gas control knob counterclockwise  to the ON position.
10. After the pilot has been lit for one minute, the burners can be turned on. Turn the ON/OFF switch to ON position or adjust thermostat to desired setting. **NOTE: To use the thermostat function (if installed) the control knob must be set to "ON" and ON/OFF switch must in the "OFF" position.**
11. If the gas logs will not operate, follow the instructions *To Turn Off Gas To Heater* below and call your service technician or gas supplier.

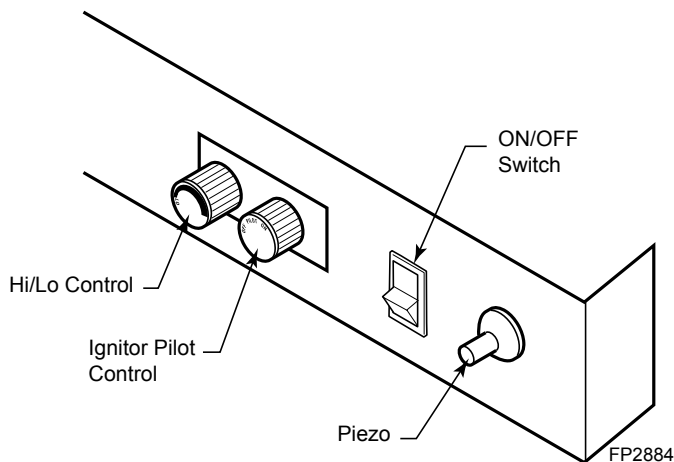
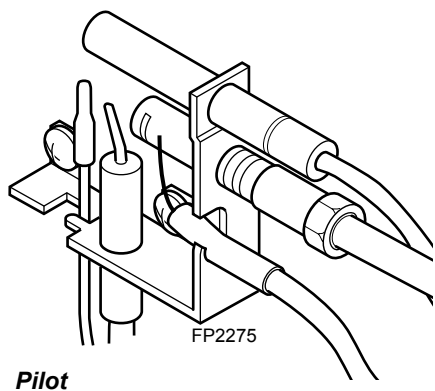

Millivolt Controls

TO TURN OFF GAS TO HEATER

1. Turn control knob clockwise  to OFF position to completely shut off the heater.
2. If applicable: Turn ON/OFF switch to OFF position and/or set thermostat (if present) to lowest setting.
3. If applicable: Turn off all electric power to the heater.

MATCH LIGHTING INSTRUCTIONS

1. Remove any items necessary for easy access to the pilot (for example: logs, screens, etc.).
2. Follow appropriate lighting instructions found previously. Instead of pushing and releasing the piezo button, light a match and hold the flame to the end of the pilot and ignite the pilot.
3. After control knob has been released and pilot stays lit, reinstall any items that were removed for pilot access.
4. Call a qualified service technician for repair or replacement of the piezo ignitor.

WARNING

Turn off heater and allow to cool before cleaning. Disconnect electrical power before cleaning or servicing.

CLEANING AND SERVICING

Annual inspection and cleaning by your dealer or qualified service technician is recommended to prevent malfunction and/or sooting.

Remove logs, handling carefully by holding gently at each end. Gloves are recommended to prevent skin irritation from ceramic fibers. If skin becomes irritated, wash gently with soap and water. Refer to manual for correct log placement.

PERIODIC CLEANING - Refer to parts diagram for location of items discussed below.

- Do not use cleaning fluid to clean logs or any part of heater.
- Brush logs with soft bristle brush or vacuum with brush attachment.
- Vacuum loose particles and dust from the front and rear burner, control and piezo covers and grate weldment.
- Inspect and clean burner air intake holes. Remove lint or particles with vacuum, brush, or pipe cleaners.
Failure to keep air intake holes clean will result in sooting and poor combustion.
- External case should be dusted and wiped with a wet soapy cloth.

ANNUAL CLEANING/INSPECTION - Refer to parts diagram for location of items discussed below.

- Inspect and clean burner air intake holes. Remove lint or particles with vacuum, brush or pipe cleaners.
Failure to keep air intake holes clean will result in sooting and poor combustion.
- Inspect and clean all burner ports.
- Inspect ODS pilot for operation and accumulation of lint at air intake holes.
- Verify flame pattern and log placement for proper operation.
- Verify smooth and responsive ignition of main burner and rear burner.
- Replace battery in remote control device.

WARNING Turn off appliance and allow to cool before cleaning.
Only a qualified service person should service and repair the heater.

NOTE: All troubleshooting items are listed in order of operation.

Problem	Possible Cause	Solution
When ignitor button is pressed, there is not spark at ODS/pilot.	1. Ignitor electrode positioned wrong.	1. Replace ignitor.
	2. Ignitor electrode is broken.	2. Replace ignitor.
	3. Ignitor electrode not connected to ignitor cable.	3. Reconnect ignitor cable.
	4. Ignitor cable pinched or wet. Keep ignitor cable dry.	4. Free ignitor cable if pinched by any metal or tubing.
	5. Broken ignitor cable.	5. Replace ignitor cable.
	6. Bad piezo ignitor.	6. Replace piezo ignitor.
Appliance produces unwanted odors.	1. Appliance burning vapors from paint, hair spray, glues, etc.	1. Ventilate room. Stop using odor causing products while heater is running.
	2. Gas leak.	2. Locate and correct leaks.
	3. Initial burn off.	3. Ventilate room and turn unit on high until odor is gone. Odor should be gone after 6 hours of continuous use.
Appliance shuts off during use.	1. Not enough fresh air is available for ODS/pilot to operate.	1. open window and/or door for ventilation.
	2. Low line pressure.	2. Contact local gas company.
	3. ODS/pilot is partially clogged.	3. Clean ODS/pilot.
	4. Defective thermopile.	4. Check wire connections. Check output should be 500 mV across TH/TP and TP terminals with ON/OFF switches off.
	5. Restrictions in incoming air flow.	5. Check for bottom riser on glass door, sunken fireplace, excessive lava rock/cinders densely packed against grate.
Gas odor even when control knob is in OFF position.	1. Gas leak.	1. Locate and correct all leaks.
	2. Control valve defective.	2. Replace control valve.
When ignitor button is pressed, there is spark at ODS/pilot, but no ignition.	1. Gas supply turned off or manual shutoff valve closed.	1. Turn on gas supply or open manual shutoff valve.
	2. Control knob not in PILOT position.	2. Turn control knob to PILOT position.
	3. Control knob not pressed in while in PILOT position.	3. Press in control knob while in PILOT position.
	4. Air in gas lines when installed.	4. Continue holding down control knob. Repeat igniting operation until air is removed.
	5. ODS/pilot is clogged.	5. Replace ODS/pilot assembly or get it serviced.
	6. Gas regulator setting is not correct.	6. Check incoming pressure. Replace gas regulator.

Problem	Possible Cause	Solution
ODS/pilot lights, but flame goes out when control knob is released.	1. Control knob not fully pressed in.	1. Press in control knob fully.
	2. Control knob not pressed in long enough.	2. After ODS/pilot lights, keep control knob pressed in for 30 seconds.
	3. Manual shutoff valve not fully open.	3. Fully open manual shutoff valve.
	4. Thermocouple connection loose at control valve.	4. Hand tighten thermocouple connection until snug, then tighten 1/4 turn more.
	5. Pilot flame not touching thermocouple, which allows thermocouple to cool, causing pilot flame to go out. This problem could be caused by either low gas pressure, or a dirty or partially clogged ODS/pilot.	5. Contact local gas company.
	6. Thermocouple damaged.	6. Replace thermocouple.
	7. Control valve damaged.	7. Replace control valve.
Burner does not light after ODS/pilot is lit.	1. Burner orifice is clogged.	1. Clean burner or replace burner orifice.
	2. Burner orifice diameter is too small.	2. Replace burner orifice.
	3. Inlet gas pressure is too low.	3. Contact qualified service person.
Burner backfires during combustion.	1. Manifold Pressure is too low.	1. Contact local gas company.
	2. Burner orifice is clogged.	2. Clean burner or replace burner orifice.
Slight smoke or odor during initial operation.	1. Burner orifice is clogged or damaged.	1. Clean burner or replace burner orifice.
	2. Burner is damaged.	2. Replace burner.
	3. Gas regulator is defective.	3. Replace gas regulator.
Logs appear to smoke after initial operation.	1. Vapors from paint or curing process of logs.	1. Problem will stop after a few hours of operation. Run the heater with the damper open if you have one, or open a window for the first few hours. 2. Log heater is intended to be smokeless. Turn OFF heater and call qualified service person.
Heater produces a whistling noise when burner is lit.	1. Turning control knob to HIGH position when burner is cold.	1. Turn control knob to LOW position and let warm up for a minute.
	2. Air in gas line.	2. Operate burner until air is removed from line. Have gas line checked by local gas company.
	3. Dirty or partially clogged burner orifices.	3. Clean burner or replace burner orifice.
No gas to pilot.	1. LP regulator shut down due to inlet pressure too high.	1. Verify LP tank regulator is installed and set at 11" to 13" w.c. 2. Replace regulator on heater.

WARNING

If the gas quality is bad, your pilot may not stay lit, the burners may produce soot and the heater may backfire when lit. If the gas quality or pressure is low, contact your local gas supplier immediately.

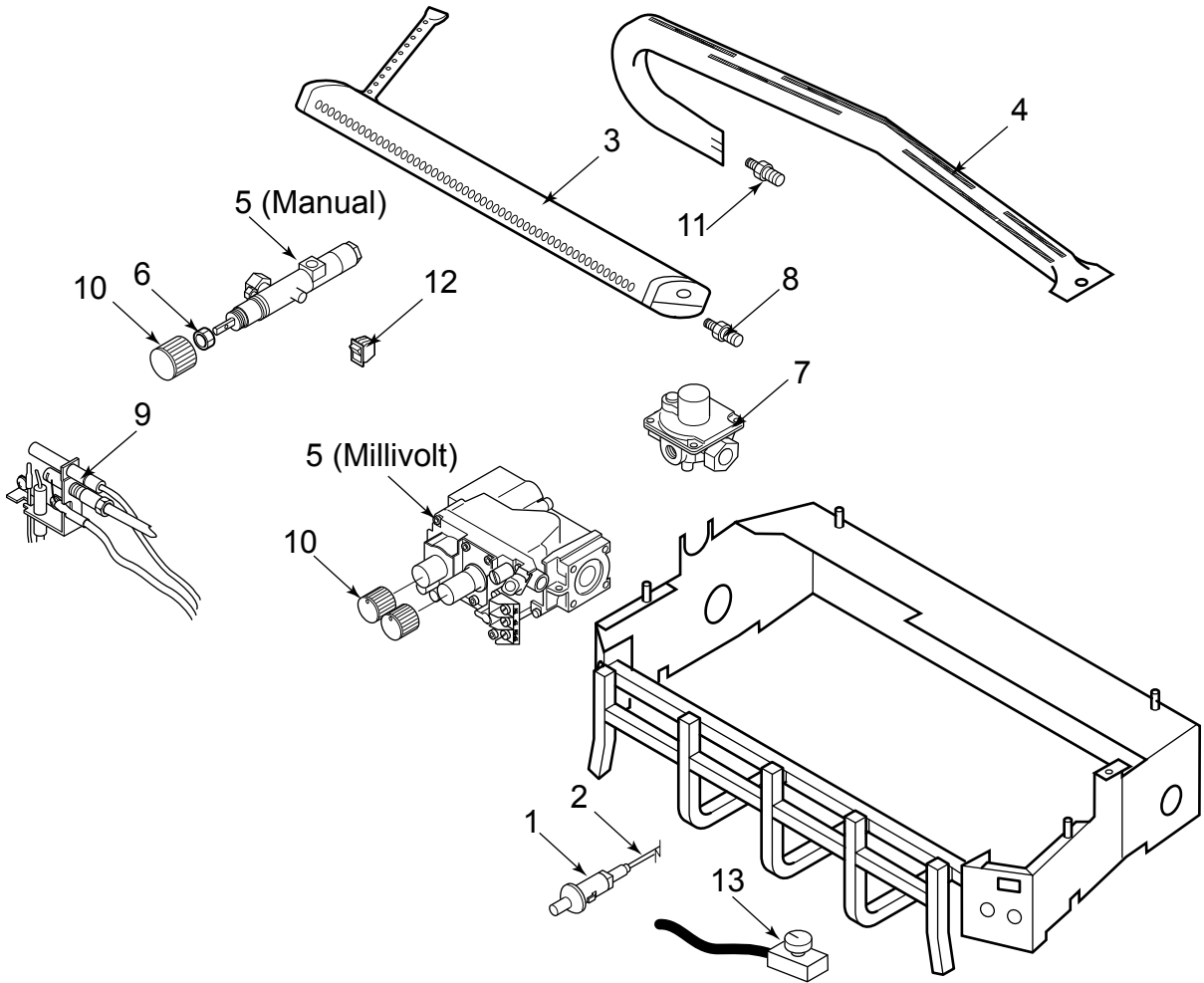

WARNING Failure to position the parts in accordance with these diagrams or failure to use only parts specifically approved with this appliance may result in property damage or personal injury.

Ref.	Description	Qty.	DEB20		DEB24/30	
			Natural	Propane	Natural	Propane
1.	Piezo Ignitor	1	14D0503	14D0503	14D0503	14D0503
2.	Piezo Wire	1	00K0632	00K0632	00K0632	00K0632
3.	Front Burner	1	44D0020K	44D0020K	44D0019K	44D0019K
4.	Rear Burner	1	44D0035K	44D0036K	44D0081K	44D0082K
Manual Control						
5.	Control Valve	1	30D0201	30D0202	30D0201	30D0202
6.	Control Valve Nut	1	00F0586	00F0586	00F0586	00F0586
7.	Valve Regulator	1	24D0305	24D0305	24D0305	24D0305
8.	Front Burner Injector	1	44D0200	44D0202	44D0204	44D0206
9.	ODS Pilot Assembly	1	26D2529	14D0476	26D2529	14D0476
10.	Control Knob	1	18D0603	18D0603	18D0603	18D0603
11.	Rear Burner Injector	1	44D0201	44D0203	44D0205	44D0207
Millivolt Control						
5.	Control Valve	1	14D0467	14D0468	14D0467	14D0468
8.	Front Burner Injector	1	44D0208	44D0210	44D0212	44D0214
9.	ODS Pilot Assembly	1	14D0473	14D0477	14D0473	14D0477
10.	Control Knob	1	18D0603	18D0603	18D0603	18D0603
11.	Rear Burner Injector	1	44D0209	44D0211	44D0213	44D0215
12.	On/Off Switch	1	32D0232	32D0232	32D0232	32D0232
13.	Thermostat Sensor	1	26D3314	26D3314	26D3314	26D3314

Accessories

Thermostat Sensor Kit	TS	All Models
Flex Connector	Flexcon 30	All Models
Wall Switch Kit	MVWS	Millivolt Only
Wall Thermostat Kit	WT	Millivolt Only
Hand Held Remote	RCT, RCB	Millivolt Only
Hand Held Thermostat Remote	RCT, RCST	Millivolt Only
Remote Receiver Cover Ember	RRCE	All Models
Remote Receiver Cover Metal	RRCM	All Models

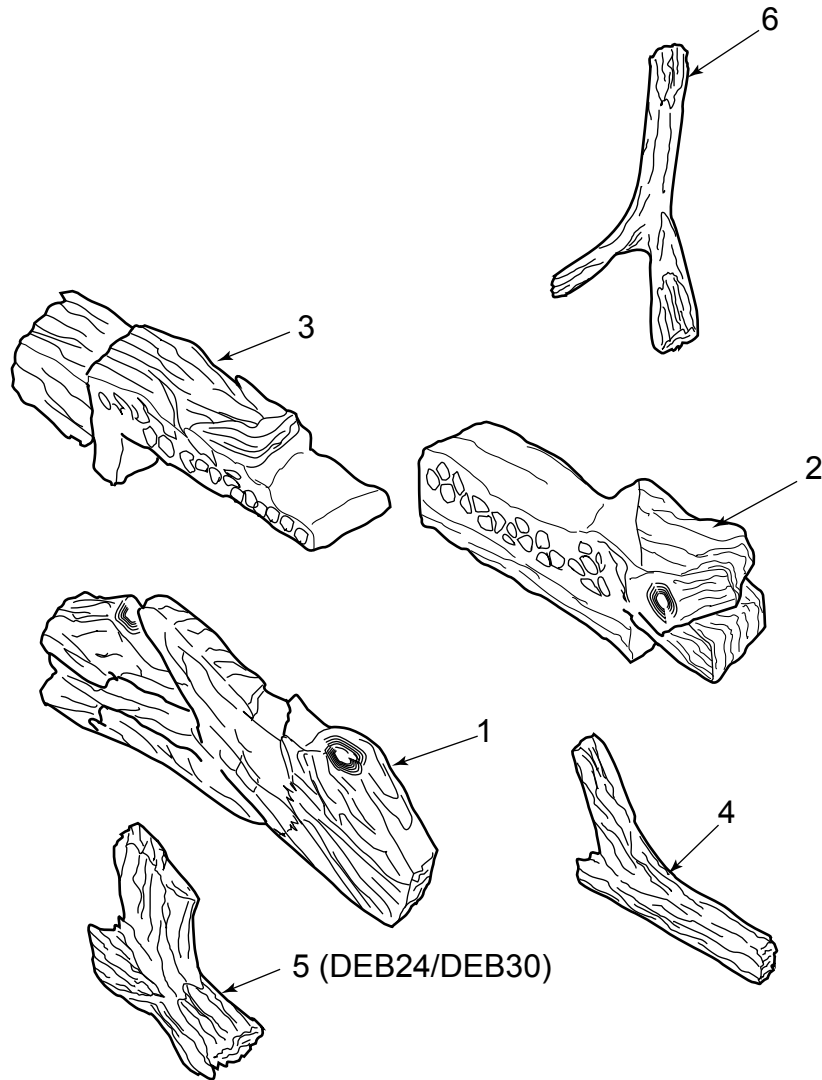

Ref.	Description	Qty.	DEB18	DEB24	DEB30
1.	Back Log	1	44D1011K	44D1001K	44D1006K
2.	Right Center Log	1	44D1022K	44D1020K	44D1024K
3.	Left Center Log	1	44D1023K	44D1021K	44D1025K
4.	Middle Front Log	1	44D1012K	44D1002K	44D1007K
5.	Left Front Log	1	--	44D1003K	44D1008K
6.	Top Log	1	44D1013K	44D1004K	44D1009K

WARNING Failure to position the parts in accordance with these diagrams or failure to use only parts specifically approved with this appliance may result in property damage or personal injury.

Massachusetts Residents Only — Please read and follow these special requirements

NOTE REGARDING VENTED PRODUCTS

This product must be installed by a licensed plumber or gas fitter when installed within the Commonwealth of Massachusetts.

Any residence with a direct vent product must have a CO detector installed in the residence.

Installation of the fireplace or vented gas log in the State of Massachusetts requires the damper to be permanently removed or welded in the fully open position.

In addition, a naturally vented gas log may not be installed in a bedroom or bathroom in the State of Massachusetts.

Flex line installation must not exceed 36 inches and must have a T shutoff valve.

NOTE REGARDING VENT FREE PRODUCTS

This product must be installed by a licensed plumber or gas fitter when installed within the Commonwealth of Massachusetts.

In addition, vent free products may not be installed in a bedroom or bathroom regardless of size or type in the State of Massachusetts.

Flex line installation must not exceed 36 inches and must have a T shutoff valve.

CARBON MONOXIDE DETECTOR REQUIREMENTS

(2) Revise 10.8.3 by adding the following additional requirements:

(a) For all side wall horizontally vented gas fueled equipment installed in every dwelling, building or structure used in whole or in part for residential purposes, including those owned or operated by the Commonwealth and where the side wall exhaust vent termination is less than seven (7) feet above finished grade in the area of the venting, including but not limited to decks and porches, the following requirements shall be satisfied:

1. **Installation of carbon monoxide detectors.** At the time of installation of the side wall horizontal vented gas fueled equipment, the installing plumber or gas fitter shall observe that a hard wired carbon monoxide detector with an alarm and battery back-up is installed on the floor level where the gas equipment is to be installed. In addition, the installing plumber or gas fitter shall observe that a battery operated or hard wired carbon monoxide detector with an alarm is installed on each additional level of the dwelling, building or structure served by the side wall horizontal vented gas fueled equipment. It shall be the responsibility of the property owner to secure the services of qualified licensed professionals for the installation of hard wired carbon monoxide detectors

a. In the event that the side wall horizontally vented gas fueled equipment is installed in a crawl space or an attic, the hard wired carbon monoxide detector with alarm and battery back-up may be installed on the next adjacent floor level.

b. In the event that the requirements of this subdivision can not be met at the time of completion of installation, the owner shall have a period of thirty (30) days to comply with the above requirements; provided, however, that during said thirty (30) day period, a battery operated carbon monoxide detector with an alarm shall be installed.

2. **Approved Carbon Monoxide Detectors.** Each carbon monoxide detector as required in accordance with the above provisions shall comply with NFPA 720 and be ANSI/UL 2034 listed and IAS certified.

3. **Signage.** A metal or plastic identification plate shall be permanently mounted to the exterior of the building at a minimum height of eight (8) feet above grade directly in line with the exhaust vent terminal for the horizontally vented gas fueled heating appliance or equipment. The sign shall read, in print size no less than one-half (1/2) inch in size, "GAS VENT DIRECTLY BELOW. KEEP CLEAR OF ALL OBSTRUCTIONS."

4. **Inspection.** The state or local gas inspector of the side wall horizontally vented gas fueled equipment shall not approve the installation unless, upon inspection, the inspector observes carbon monoxide detectors and signage installed in accordance with the provisions of 248 CMR 5.08(2)(a)1 through 4.

(b) **Exemptions:** The following equipment is exempt from 248 CMR 5.08(2)(a)1 through 4:

1. The equipment listed in Chapter 10 entitled "Equipment Not Required To Be Vented" in the most current edition of NFPA 54 as adopted by the Board; and

2. Product Approved side wall horizontally vented gas fueled equipment installed in a room or structure separate from the dwelling, building or structure used in whole or in part for residential purposes.

(c) **Manufacturer requirements — Gas Equipment Venting System Provided.** When the manufacturer of Product Approved side wall horizontally vented gas equipment provides a venting system design or venting system components with the equipment, the instructions provided by the manufacturer for installation of the equipment and the venting system shall include:

1. Detailed instructions for the installation of the venting system design or the venting system components; and

2. A complete parts list for the venting system design or venting system.

(d) **Manufacturer requirements — Gas Equipment Venting System Not Provided.** When the manufacturer of a Product Approved side wall horizontally vented gas fueled equipment does not provide the parts for venting the flue gases, but identifies "special venting systems," the following requirements shall be satisfied by the manufacturer:

1. The referenced "special venting system" instructions shall be included with the appliance or equipment installation instructions; and

2. The "special venting systems" shall be Product Approved by the Board, and the instructions for that system shall include a parts list and detailed installation instructions.

(e) A copy of all installation instructions for all Product Approved side wall horizontally vented gas fueled equipment, all venting instructions, all parts lists for venting instructions, and/or all venting design

LIMITED LIFETIME WARRANTY

LIFETIME WARRANTY

The following components are warranted for life to the original owner, subject of proof of purchase: Firebox, Combustion Chamber, Heat Exchanger, Grate, and Stainless Steel Burners.

FIVE YEAR WARRANTY

The following components are warranted for 5 years to the original owner, subject of proof of purchase: Vent Free Ceramic Fiber Logs and Aluminized Burners.

BASIC WARRANTY

Monessen warrants the components and materials in your gas appliance to be free from manufacturing and material defects for a period of two years from date of installation. After installation, if any of the components manufactured by Monessen in the appliance are found to be defective in materials or workmanship, Monessen will, at its option, replace or repair the defective components at no charge to the original owner. Monessen will also pay for reasonable labor costs incurred in replacing or repairing such components for a period of two years from the date of installation. Any products presented for warranty repair must be accompanied by a dated proof of purchase.

This Limited Lifetime Warranty will be void if the appliance is not installed by a qualified installer in accordance with the installation instructions. The Limited Lifetime Warranty will also be void if the appliance is not operated and maintained according to the operating instructions supplied with the appliance, and does not extend to (1) firebox/burner assembly damage by accident, neglect, misuse, abuse, alteration, negligence of others, including the installation thereof by unqualified installers, (2) the costs of removal, reinstallation or transportation of defective parts on the appliance, or (3) incidental or consequential damage. All service work must be performed by an authorized service representative.

This warranty is expressly in lieu of other warranties, express or implied, including the warranty of merchantability of fitness for purpose and of all other obligations or liabilities. Monessen does not assume for it any other obligations or liability in connection with the sale or use of the appliance. In states that do not allow limitations on how long an implied warranty lasts, or do not allow exclusion of indirect damage, those limitations of exclusions may not apply to you. You may also have additional rights not covered in this Limited Lifetime Warranty.

Monessen reserves the right to investigate any and all claims against the Limited Lifetime Warranty and decide upon method of settlement.

IF WARRANTY SERVICE IS NEEDED...

1. Contact your supplier. Make sure you have your warranty, your sales receipt and the model/serial number of your Monessen product.
2. DO NOT ATTEMPT TO DO ANY SERVICE WORK YOURSELF.



LOVE AT FIRST LIGHT

Monessen, a brand of Hearth & Home Technologies
7571 215th Street West, Lakeville, MN 50044
www.monessenhearth.com